

## CODO FIG 92 90° M-H.

- Fabricado en A-316 (microfusión)
- Extremos roscados EN 10226-1 (ISO 7/1).
- Elemento normalizado según ISO 4144
- Presión máxima 150 psi (10 bar).
- Temperatura máxima de operación 220 °C.

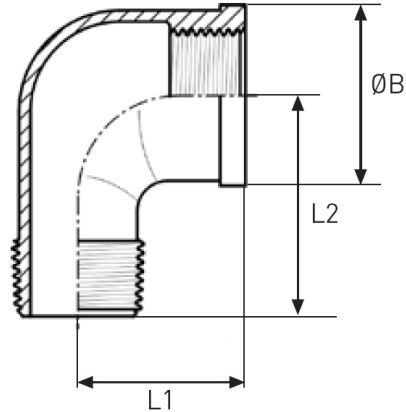

Código	DN	B (mm)	L1 (mm)	L2 (mm)	Bolsa (uds.)	Peso (kg/u.)
C090I006	1/8"	17,0	19,0	25,0	10	0,03
C090I008	1/4"	21,0	21,0	28,3	10	0,07
C090I010	3/8"	25,0	25,0	32,0	10	0,08
C090I015	1/2"	29,0	28,0	42,0	10	0,10
C090I020	3/4"	35,0	33,0	50,5	10	0,17
C090I025	1"	43,0	38,0	52,0	10	0,22
C090I032	1.1/4"	52,0	45,0	60,0	5	0,38
C090I040	1.1/2"	58,8	50,0	65,0	5	0,49
C090I050	2"	71,7	58,0	74,0	5	0,78
C090I065	2.1/2"	86,2	69,0	101,0	4	1,25
C090I080	3"	100,0	77,0	114,5	1	1,85
C090I100	4"	126,5	97,0	146,5	1	3,11