

Ref. M0

HSS

DIN 352

DIN 2181

TOL 6H

Ref. C5



HSS

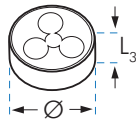
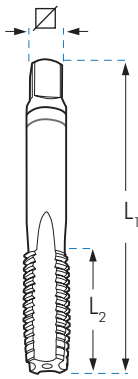

DIN 223

TOL 6g

Para materiales hasta 38 HRC



		M0			C5	
	Uds.		L1 x L2 x ∇ mm	€	Ø x L3 mm	€
M 5,5x0,90	3	4,60	50 x 16 x 4,9	80,42	25 x 9	90,56
M 6x0,50	2	5,50	50 x 14 x 4,9	27,30	20 x 5	35,04
M 6x0,75	2	5,25	50 x 14 x 4,9	23,05	25 x 9	28,74
M 6x1,00	3	5,00	50 x 19 x 4,9	20,42*	25 x 9	25,57*
M 6x1,25	3	4,75	50 x 19 x 4,9	131,93	25 x 9	92,73
M 7x0,75	2	6,25	50 x 14 x 4,9	29,44	25 x 9	28,45
M 7x1,00	3	6,00	50 x 19 x 4,9	24,86*	25 x 9	27,59*
M 7x1,25	3	5,75	50 x 19 x 4,9	91,67	25 x 9	111,44
M 8x0,50	2	7,50	50 x 16 x 4,9	46,87	25 x 9	42,47
M 8x0,75	2	7,25	50 x 16 x 4,9	31,71	25 x 9	30,77
M 8x1,00	2	7,00	56 x 18 x 4,9	22,93*	25 x 9	29,66*
M 8x1,25	3	6,80	56 x 22 x 4,9	24,84*	25 x 9	27,13*
M 8x1,50	3	6,50	56 x 22 x 4,9	89,16	25 x 9	96,88
M 9x1,00	2	8,00	63 x 18 x 5,5	32,69	25 x 9	32,96
M 9x1,25	3	7,80	63 x 22 x 5,5	40,70*	25 x 9	31,53*
M 10x0,50	2	9,50	63 x 18 x 5,5	49,67	30 x 10	107,06
M 10x0,75	2	9,25	63 x 18 x 5,5	49,42	30 x 11	52,64
M 10x1,00	2	9,00	63 x 18 x 5,5	24,56	38 x 10	34,90
M 10x1,25	2	8,80	70 x 24 x 5,5	24,90	38 x 10	37,23
M 10x1,50	3	8,50	70 x 24 x 5,5	30,63*	38 x 10	36,31*
M 11x0,75	2	10,25	63 x 18 x 6,2	74,56	30 x 11	115,66
M 11x1,00	2	10,00	63 x 18 x 6,2	46,98	30 x 11	55,08
M 11x1,25	2	9,75	63 x 20 x 6,2	46,98	30 x 11	55,07
M 11x1,50	3	9,50	70 x 24 x 6,2	51,05	38 x 10	43,99
M 12x0,75	2	11,25	70 x 20 x 7,0	67,80	38 x 10	59,71
M 12x1,00	2	11,00	70 x 20 x 7,0	43,55	38 x 10	52,64
M 12x1,25	2	10,75	70 x 20 x 7,0	43,42	38 x 10	50,74
M 12x1,50	2	10,50	70 x 20 x 7,0	37,00*	38 x 10	45,51*
M 12x1,75	3	10,20	75 x 29 x 7,0	43,11*	38 x 14	39,45*
M 13x0,75	2	12,25	70 x 20 x 9,0	74,56	38 x 10	105,29
M 13x1,00	2	12,00	70 x 20 x 9,0	71,78	38 x 10	55,92
M 13x1,25	2	11,75	70 x 20 x 9,0	67,34	38 x 10	74,77
M 13x1,50	2	11,50	70 x 20 x 9,0	67,34	38 x 10	58,78
M 13x1,75	3	11,25	70 x 20 x 9,0	77,91	38 x 14	62,98
M 14x0,75	2	13,25	70 x 20 x 9,0	85,69	38 x 10	98,72
M 14x1,00	2	13,00	70 x 20 x 9,0	66,07	38 x 10	57,44
M 14x1,25	2	12,80	70 x 20 x 9,0	53,01*	38 x 10	57,44*
M 14x1,50	2	12,50	70 x 20 x 9,0	41,23	38 x 10	48,90
M 14x1,75	2	12,25	70 x 20 x 9,0	82,46	38 x 14	168,12
M 14x2,00	3	12,00	80 x 30 x 9,0	47,69*	38 x 14	39,07*
M 15x1,00	2	14,00	70 x 20 x 9,0	95,10	45 x 14	63,56
M 15x1,25	2	13,75	70 x 20 x 9,0	98,54	45 x 14	98,47
M 15x1,50	2	13,50	70 x 20 x 9,0	88,22	45 x 14	68,10
M 15x2,00	3	13,00	80 x 30 x 9,0	95,32	45 x 14	85,35
M 16x1,00	2	15,00	70 x 20 x 9,0	90,05	45 x 14	71,96
M 16x1,25	2	14,75	70 x 20 x 9,0	94,78	45 x 14	60,55
M 16x1,50	2	14,50	70 x 20 x 9,0	51,30*	45 x 14	55,01*
M 16x2,00	3	14,00	80 x 32 x 9,0	67,66*	45 x 18	52,96*
M 17x1,00	2	16,00	70 x 20 x 9,0	145,44	45 x 14	102,98
M 17x1,25	2	15,75	70 x 20 x 9,0	145,44	45 x 14	102,98
M 17x1,50	2	15,50	70 x 20 x 9,0	145,44	45 x 14	102,98
M 18x1,00	2	17,00	80 x 22 x 11,0	100,11	45 x 14	76,09
M 18x1,25	2	16,75	80 x 22 x 11,0	139,08	45 x 14	79,14

	Uds.		L1 x L2 x ∇ mm	€	Ø x L3 mm	€
M 1x0,20	2	0,80	32 x 5,5 x 2,1	79,25		
M 1x0,25	3	0,75	32 x 6,0 x 2,1	79,25	16 x 5	84,74
M 1,1x0,20	2	0,90	32 x 5,5 x 2,1	79,25		
M 1,1x0,25	3	0,85	32 x 6,0 x 2,1	79,25	16 x 5	83,81
M 1,2x0,20	2	1,00	32 x 5,5 x 2,1	79,25		
M 1,2x0,25	3	0,95	32 x 6,0 x 2,1	79,25	16 x 5	78,65
M 1,4x0,20	2	1,20	32 x 7,0 x 2,1	79,25		
M 1,4x0,25	2	1,15	32 x 7,0 x 2,1	79,25		
M 1,4x0,30	3	1,10	32 x 7,0 x 2,1	79,25	16 x 5	72,07
M 1,6x0,20	2	1,40	32 x 8,0 x 2,1	72,31		
M 1,6x0,25	2	1,35	32 x 8,0 x 2,1	72,31		
M 1,6x0,35	3	1,25	32 x 8,0 x 2,1	72,31	16 x 5	68,09
M 1,7x0,35	3	1,35	32 x 8,0 x 2,1	67,87	16 x 5	68,09
M 1,8x0,20	2	1,60	32 x 8,0 x 2,1	67,87		
M 1,8x0,25	2	1,55	32 x 8,0 x 2,1	67,87		
M 1,8x0,35	3	1,45	32 x 8,0 x 2,1	67,87	16 x 5	68,09
M 2x0,25	2	1,75	36 x 8,0 x 2,1	67,87		
M 2x0,35	2	1,65	36 x 8,0 x 2,1	67,87		
M 2x0,40	3	1,60	36 x 9,0 x 2,1	34,04*	16 x 5	28,11*
M 2,2x0,45	3	1,75	36 x 9,0 x 2,1	38,65	20 x 5	60,11
M 2,3x0,40	3	1,90	36 x 9,0 x 2,1	35,67	20 x 5	30,83
M 2,5x0,45	3	2,05	40 x 9,0 x 2,1	33,91	20 x 5	28,11
M 2,6x0,45	3	2,10	40 x 9,0 x 2,1	34,67	25 x 9	29,43
M 3x0,35	2	2,65	40 x 9,0 x 2,7	44,32	20 x 5	44,51
M 3x0,50	3	2,50	40 x 11,0 x 2,7	19,11*	25 x 9	25,57*
M 3x0,60	3	2,40	45 x 13,0 x 3,0	38,86	20 x 5	34,88
M 3,5x0,60	3	2,90	45 x 13,0 x 3,0	22,79	25 x 9	26,75
M 3,5x0,75	3	2,75	45 x 18,0 x 3,0	42,20	25 x 9	60,15
M 4x0,50	2	3,50	45 x 13,0 x 3,4	38,33	25 x 9	28,73
M 4x0,70	3	3,30	45 x 13,0 x 3,4	19,09*	25 x 9	25,69*
M 4x0,75	3	3,25	45 x 13,0 x 3,4	31,61	20 x 7	38,86
M 4x0,80	3	3,20	45 x 13,0 x 3,4	76,16	20 x 7	91,86
M 4,5x0,50	2	4,00	50 x 12,0 x 4,9	37,17	25 x 9	40,01
M 4,5x0,75	3	3,75	50 x 16,0 x 4,9	34,04	20 x 7	28,12
M 5x0,50	2	4,50	50 x 12,0 x 4,9	38,15	20 x 5	31,36
M 5x0,75	2	4,25	50 x 14,0 x 4,9	37,87	20 x 7	39,06
M 5x0,80	3	4,20	50 x 16,0 x 4,9	20,42*	25 x 9	25,55*
M 5x0,90	3	4,10	50 x 16,0 x 4,9	36,09	25 x 9	39,06
M 5x1,00	3	4,00	50 x 16,0 x 4,9	80,42	25 x 9	88,57

* Disponibles también con rosca izquierda con 100% de recargo sobre los precios tarifados en rosca derecha
 * Recargo por cojinetes abiertos 20% sobre los precios tarifados

M
MF

DIN 13 60°

Ref. M0

HSS

DIN 352

DIN 2181

TOL 6H

Ref. C5

HSS

DIN 223

TOL 6g

M0						C5							
Uds.	Ø	L1 x L2 x mm	€	Ø x L3 mm	€	Uds.	Ø	L1 x L2 x mm	€	Ø x L3 mm	€		
M 18x1,50	2	16,50	80 x 22 x 11,0	67,60	45 x 14	66,62	M 33x3,50	3	29,5	125 x 50 x 20,0	327,78*	65 x 25	121,47*
M 18x2,00	2	16,00	80 x 22 x 11,0	107,89*	45 x 14	74,44*	M 34x1,50	2	32,5	100 x 25 x 22,0	327,80	65 x 18	139,02
M 18x2,50	3	15,50	95 x 40 x 11,0	89,29*	45 x 18	52,98*	M 34x2,00	2	32,0	100 x 25 x 22,0	402,83	65 x 18	317,32
M 19x1,00	2	18,00	80 x 22 x 11,0	211,06	45 x 14	163,80	M 35x1,50	2	33,5	100 x 25 x 22,0	359,61	65 x 18	144,19
M 19x1,25	2	17,75	80 x 22 x 11,0	211,06	45 x 14	185,25	M 35x2,00	2	33,0	100 x 25 x 22,0	402,83	65 x 18	317,32
M 19x1,50	2	17,50	80 x 22 x 11,0	211,06	45 x 14	163,80	M 36x1,50	2	34,5	100 x 25 x 22,0	351,10	65 x 18	136,50
M 19x2,00	2	17,00	80 x 22 x 11,0	250,55	45 x 14	187,13	M 36x2,00	2	34,0	125 x 33 x 22,0	450,05	65 x 18	142,37
M 20x1,00	2	19,00	80 x 22 x 12,0	132,65	45 x 14	76,09	M 36x3,00	2	33,0	125 x 33 x 22,0	594,41*	65 x 25	142,84*
M 20x1,25	2	18,75	80 x 22 x 12,0	210,29	45 x 14	165,15	M 36x4,00	3	32,0	150 x 53 x 22,0	418,16*	65 x 25	123,84*
M 20x1,50	2	18,50	80 x 22 x 12,0	84,65	45 x 14	70,04	M 38x1,50	2	36,5	100 x 25 x 22,0	394,93	75 x 20	208,56
M 20x2,00	2	18,00	80 x 22 x 12,0	111,23*	45 x 14	76,09*	M 38x2,00	2	36,0	125 x 25 x 22,0	541,20	75 x 20	395,19
M 20x2,50	3	17,50	95 x 40 x 12,0	100,17*	45 x 18	53,63*	M 39x1,50	2	37,5	110 x 25 x 24,0	522,71	75 x 20	207,45
M 21x1,00	2	20,00	80 x 22 x 12,0	270,42	45 x 14	200,68	M 39x2,00	2	37,0	125 x 23 x 24,0	522,71	75 x 20	219,07
M 21x1,25	2	19,75	80 x 22 x 12,0	270,42	45 x 14	200,68	M 39x3,00	2	36,0	125 x 33 x 24,0	504,21*	75 x 30	223,76*
M 21x1,50	2	19,50	80 x 22 x 12,0	210,50	45 x 14	165,42	M 39x4,00	3	35,0	150 x 53 x 24,0	472,35*	75 x 30	188,36*
M 22x1,00	2	21,00	80 x 22 x 14,5	148,65	55 x 16	102,43	M 40x1,50	2	38,5	110 x 25 x 24,0	463,77	75 x 20	217,92
M 22x1,25	2	20,75	80 x 22 x 14,5	208,27	55 x 16	166,93	M 40x2,00	2	38,0	125 x 33 x 24,0	520,00	75 x 20	202,36
M 22x1,50	2	20,50	80 x 22 x 14,5	93,10	55 x 16	88,12	M 40x3,00	2	37,0	125 x 33 x 24,0	518,10	75 x 30	220,69
M 22x2,00	2	20,00	80 x 22 x 14,5	148,51*	55 x 16	98,05*	M 42x1,50	2	40,5	110 x 25 x 24,0	513,28	75 x 20	242,30
M 22x2,50	3	19,50	100 x 40 x 14,5	134,52*	55 x 22	78,36*	M 42x2,00	2	40,0	125 x 33 x 24,0	597,60	75 x 20	328,55
M 23x1,00	2	22,00	80 x 22 x 14,5	272,77	55 x 16	217,06	M 42x3,00	2	39,0	125 x 33 x 24,0	600,17	75 x 30	242,30
M 23x1,50	2	21,50	80 x 22 x 14,5	271,71	55 x 16	200,68	M 42x4,50	3	37,5	150 x 53 x 24,0	585,43	75 x 30	188,34
M 24x1,00	2	23,00	90 x 22 x 14,5	164,81	55 x 16	99,91	M 45x1,50	2	43,5	110 x 25 x 29,0	560,65	90 x 22	283,13
M 24x1,25	2	22,75	90 x 22 x 14,5	269,36	55 x 16	170,10	M 45x2,00	2	43,0	125 x 33 x 29,0	717,68	90 x 22	307,37
M 24x1,50	2	22,50	90 x 22 x 14,5	118,69	55 x 16	89,78	M 45x3,00	2	42,0	125 x 33 x 29,0	717,68	90 x 36	320,70
M 24x2,00	2	22,00	90 x 22 x 14,5	172,35*	55 x 16	99,91*	M 45x4,50	3	40,5	160 x 60 x 29,0	675,83	90 x 36	291,84
M 24x3,00	3	21,00	110 x 50 x 14,5	159,15*	55 x 22	78,36*	M 48x1,50	2	46,5	140 x 33 x 29,0	625,93	90 x 22	276,68
M 25x1,00	2	24,00	90 x 22 x 14,5	232,49	55 x 16	151,61	M 48x2,00	2	46,0	140 x 33 x 29,0	937,95	90 x 22	303,05
M 25x1,25	2	23,75	90 x 22 x 14,5	296,34	55 x 16	256,00	M 48x3,00	2	45,0	140 x 33 x 29,0	869,68	90 x 36	292,36
M 25x1,50	2	23,50	90 x 22 x 14,5	213,48	55 x 16	130,42	M 48x5,00	3	43,0	180 x 65 x 29,0	813,71	90 x 36	292,19
M 25x2,00	2	23,00	90 x 22 x 14,5	396,52	55 x 16	248,90	M 50x1,50	2	48,5	140 x 33 x 29,0	684,53	90 x 22	288,49
M 26x1,00	2	25,00	90 x 22 x 14,5	207,84	55 x 16	192,71	M 50x3,00	2	57,0	140 x 33 x 29,0	922,53	90 x 22	314,42
M 26x1,50	2	24,50	90 x 22 x 14,5	195,00	55 x 16	121,16	M 52x1,50	2	50,5	140 x 33 x 32,0	724,63	90 x 22	294,60
M 26x2,00	2	24,00	90 x 22 x 14,5	228,80	55 x 16	217,77	M 52x2,00	2	50,0	140 x 33 x 32,0	1.051,37	90 x 22	342,36
M 27x1,00	2	26,00	90 x 22 x 16,0	228,82	65 x 18	135,18	M 52x3,00	2	49,0	140 x 33 x 32,0	967,97	90 x 36	373,61
M 27x1,50	2	25,50	90 x 22 x 16,0	215,01	65 x 18	135,76	M 52x5,00	3	47,0	180 x 65 x 32,0	983,52	90 x 36	292,19
M 27x2,00	2	25,00	90 x 22 x 16,0	238,85*	65 x 18	147,65*	M 56x4,00	2	52,0	180 x 47 x 32,0	1.079,36	105 x 36	
M 27x3,00	3	24,00	110 x 50 x 16,0	202,89*	65 x 25	118,88*	M 56x5,50	3	50,5	200 x 85 x 35,0	1.526,53	105 x 36	
M 28x1,00	2	27,00	90 x 22 x 16,0	386,18	65 x 18	224,08	M 60x5,50	3	54,5	200 x 85 x 35,0	1.543,88	105 x 36	
M 28x1,50	2	26,50	90 x 22 x 16,0	216,62	65 x 18	123,07	M 64x4,00	2	60,0	180 x 50 x 35,0	1.520,11	120 x 36	
M 28x2,00	2	26,00	90 x 22 x 16,0	259,18	65 x 18	221,90	M 64x6,00	3	58,0	220 x 90 x 39,0	1.877,08	120 x 36	
M 30x1,00	2	29,00	90 x 22 x 18,0	240,56	65 x 18	143,26	M 68x6,00	3	62,0	220 x 90 x 39,0	2.247,22	120 x 36	
M 30x1,50	2	28,50	90 x 22 x 18,0	224,67	65 x 18	135,75	M 72x6,00	3	66,0	235 x 90 x 39,0	2.434,62	120 x 36	
M 30x2,00	2	28,00	90 x 22 x 18,0	259,01	65 x 18	150,45	COJINETES CON MEDIDA EXTERIOR EN PULGADAS						
M 30x3,00	2	27,00	125 x 56 x 18,0	260,18*	65 x 25	214,90*						C5	
M 30x3,50	3	26,50	125 x 50 x 18,0	261,12*	65 x 25	119,19*						€	
M 32x1,00	2	31,00	90 x 22 x 18,0	317,22	65 x 18	237,28						Ø x L3 mm	
M 32x1,50	2	30,50	90 x 22 x 18,0	267,51	65 x 18	140,80						€	
M 32x2,00	2	30,00	90 x 22 x 18,0	393,45	65 x 18	219,91	M 3x0,50	25,4 x 9	22,54	M 8x1,25	38,1 x 9	23,92	
M 33x1,00	2	32,00	100 x 25 x 20,0	506,25	65 x 18	251,24	M 4x0,70	25,4 x 9	22,54	M10x1,50	25,4 x 9	30,27	
M 33x1,50	2	31,50	100 x 25 x 20,0	286,10	65 x 18	133,23	M 5x0,80	25,4 x 9	22,96	M10x1,50	38,1 x 10	30,27	
M 33x2,00	2	31,00	100 x 25 x 20,0	361,22	65 x 18	134,14	M 6x1,00	25,4 x 9	22,54	M12x1,75	25,4 x 9	36,48	
M 33x3,00	2	30,00	125 x 56 x 20,0	468,34*	65 x 25	265,46*	M 8x1,25	25,4 x 9	23,92	M12x1,75	38,1 x 14	36,48	

* Disponibles también con rosca izquierda con 100% de recargo sobre los precios tarifados en rosca derecha
 * Recargo por cojinetes abiertos 20% sobre los precios tarifados

UNC

Ref. M0

HSS

DIN 351

TOL 2B

Ref. C5

HSS

DIN 223

TOL 2a

UNF

Ref. M0

HSS

DIN 2181

TOL 2B

Ref. C5

HSS

DIN 223

TOL 2a

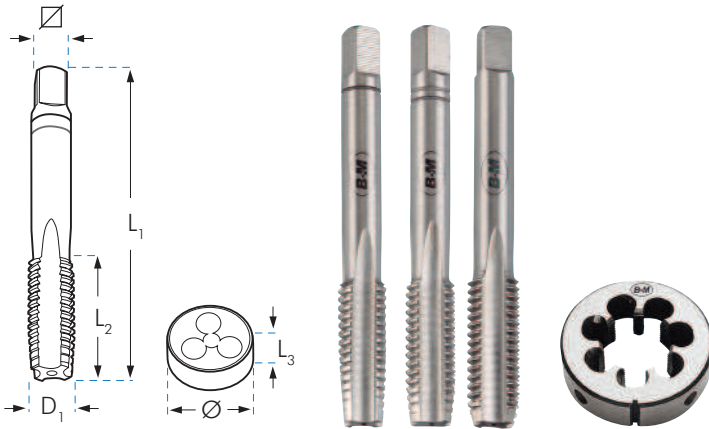

UNC	n°	Uds.	D1 mm	L1 x L2 x mm	M0		C5	
					€	Ø x L3 mm	€	
UNC n°1-64h.	3	1,85	1,50	36x8x2,1	93,02	16x5		
UNC n°2-56h.	3	2,18	1,80	36x9x2,1	65,73	16x5		
UNC n°3-48h.	3	2,51	2,10	40x9x2,1	65,73	16x5		
UNC n°4-40h.	3	2,84	2,25	40x11x2,7	49,78	20x5	36,94	
UNC n°5-40h.	3	3,17	2,60	40x11x2,7	47,59	20x5	37,03	
UNC n°6-32h.	3	3,50	2,75	45x13x3,0	47,59	20x7	37,03	
UNC n°8-32h.	3	4,17	3,50	45x13x3,4	47,59	20x7	37,03	
UNC n°10-24h.	3	4,83	3,90	50x16x4,9	47,59	20x7	37,03	
UNC n°12-24h.	3	5,49	4,50	50x19x4,9	47,59	20x7	37,03	
UNC 1/4-20h.	3	6,35	5,10	50x19x4,9	40,78*	20x7	34,90*	
UNC 5/16-18h.	3	7,94	6,60	56x22x4,9	46,31*	25x9	35,82*	
UNC 3/8-16h.	3	9,52	8,00	70x24x5,5	52,68*	30x11	49,79*	
UNC 7/16-14h.	3	11,11	9,40	70x24x6,2	68,60	38x14	49,79	
UNC 1/2-13h.	3	12,70	10,75	75x29x7,0	78,93*	38x14	51,19*	
UNC 9/16-12h.	3	14,28	12,20	80x30x9,0	93,18	38x14	53,57	
UNC 5/8-11h.	3	15,87	13,50	80x32x9,0	128,50*	45x18	72,62*	
UNC 3/4-10h.	3	19,05	16,50	95x40x11,0	175,09*	45x18	72,62*	
UNC 7/8-9h.	3	22,22	19,50	100x40x14,5	215,54	55x22	101,39	
UNC 1"-8h.	3	25,40	22,25	110x50x14,5	291,05*	55x22	97,47*	
UNC 1.1/8-7h.	3	28,57	25,00	125x56x18,0	438,84	65x25	144,80	
UNC 1.1/4-7h.	3	31,75	28,00	125x56x18,0	552,36	65x25	144,80	
UNC 1.3/8-6h.	3	34,92	30,75	150x63x22,0	700,74	65x25	144,80	
UNC 1.1/2-6h.	3	38,10	34,00	150x63x24,0	860,37	75x30	225,76	
UNC 2"-4,5h.	3	50,80	45,00	180x75x32,0	1.853,17	90x36		

UNF	n°	Uds.	D1 mm	L1 x L2 x mm	M0		C5	
					€	Ø x L3 mm	€	
UNF n°2-64h.	2	2,18	1,85	36x8x2,1	59,57			
UNF n°3-56h.	2	2,51	2,15	40x9x2,1	59,57			
UNF n°4-48h.	2	2,84	2,35	40x9x2,7	37,12	20x5	38,39	
UNF n°5-44h.	2	3,17	2,70	45x10x2,7	37,12	20x5	37,03	
UNF n°6-40h.	2	3,50	2,95	45x16x3,0	35,47	20x5	37,03	
UNF n°8-36h.	2	4,17	3,50	50x12x3,4	35,47	20x7	37,03	
UNF n°10-32h.	2	4,83	4,10	50x12x4,9	35,47	20x7	37,03	
UNF n°12-28h.	2	5,49	4,60	50x12x4,9	37,12	20x7	37,03	
UNF 1/4-28h.	2	6,35	5,50	50x14x4,9	27,07*	25x9	32,70*	
UNF 5/16-24h.	2	7,94	6,90	56x22x4,9	28,98*	25x9	36,50*	
UNF 3/8-24h.	2	9,52	8,50	63x20x5,5	33,46*	38x10	49,79*	
UNF 7/16-20h.	2	11,11	9,90	63x20x6,2	44,42	38x10	48,86	
UNF 1/2-20h.	2	12,70	11,50	70x22x7,0	45,43*	38x10	53,22*	
UNF 9/16-18h.	2	14,29	12,90	70x22x9,0	59,21	38x10	55,72	
UNF 5/8-18h.	2	15,87	14,50	70x22x9,0	76,48*	45x14	72,62*	
UNF 3/4-16h.	2	19,05	17,50	80x22x11,0	102,73*	45x14	72,62*	
UNF 7/8-14h.	2	22,22	20,40	80x22x14,5	132,03*	55x16	97,47*	
UNF 1"-12h.	2	25,40	23,25	90x22x16,0	175,07	55x16	97,47	
UNS 1"-14h.	2	25,40	23,60	90x22x14,5	193,93*	55x16	105,91*	
UNF 1.1/8-12h.	2	28,57	26,50	90x22x18,0	258,38	65x18	118,70	
UNF 1.1/4-12h.	2	31,75	29,50	90x22x20,0	315,56	65x18	150,59	
UNF 1.3/8-12h.	2	34,92	32,80	125x35x22,0	425,72	65x18	157,65	
UNF 1.1/2-12h.	2	38,10	36,00	125x40x22,0	537,83	75x20	225,76	
UNF 2"-12h.	2	50,80	48,38	140x40x29,0	1.330,81	90x22		

* Disponibles también con rosca izquierda con 100% de recargo sobre los precios tarifados en rosca derecha

BSP (GAS) Ref. M0 **DIN 5157 TOL ISO 228** Ref. C5 **DIN 5158** Ref. M0T Ref. M0X **DIN 352 TOL 6H** Ref. C5T Ref. C5X **DIN 5158 TOL 6g**



Icon	Uds.	D1 mm	L1 x L2 x mm	M0		C5		Icon	Uds.	M0T		C5T		M0X		C5X	
				HSS	€	HSS	€			HSS	€	HSS	€	HSSCo	OX	€	HSSCo
G 1/8-28h.	2	9,73	8,80	63 x 20 x 5,5	31,10*	30 x 11	44,53*	G 1/8-28 h.	2	68,30	87,71	78,48	90,32				
G 1/4-19h.	2	13,16	11,80	70 x 22 x 9,0	43,83*	38 x 10	44,29*	G 1/4-19 h.	2	124,28	90,77	141,04	90,56				
G 3/8-19h.	2	16,66	15,25	70 x 22 x 9,0	55,02*	45 x 14	58,66*	G 3/8-19 h.	2	151,62	102,11	175,20	96,96				
G 1/2-14h.	2	20,95	19,00	80 x 22 x 12,0	77,16*	45 x 14	58,66*	G 1/2-14 h.	2	213,70	115,58	236,39	122,62				
G 5/8-14h.	2	22,91	21,00	80 x 22 x 14,5	98,73*	55 x 16	81,38*										
G 3/4-14h.	2	26,44	24,50	90 x 22 x 16,0	120,45*	55 x 16	105,93*	G 3/4-14 h.	2	280,35	188,31	339,31	200,55				
G 7/8-14h.	2	30,20	28,25	90 x 22 x 18,0	162,15	65 x 18	126,11										
G 1"-11h.	2	33,25	30,75	100 x 25 x 20,0	190,95*	65 x 18	127,32*	G 1" -11 h.	2	488,62	251,54	558,09	291,50				
G 1.1/8-11h.	2	37,90	35,50	125 x 40 x 22,0	296,57	75 x 20	179,70										
G 1.1/4-11h.	2	41,91	39,50	125 x 40 x 24,0	323,19*	75 x 20	176,40*										
G 1.3/8-11h.	2	44,32	42,00	125 x 40 x 29,0	438,96	90 x 22	284,03										
G 1.1/2-11h.	2	47,80	45,25	140 x 40 x 29,0	488,43	90 x 22	273,61										
G 1.3/4-11h.	2	53,75	51,25	140 x 40 x 32,0	812,00	105 x 22	284,03										
G 2"-11h.	2	59,61	57,00	160 x 40 x 35,0	902,88	105 x 22	341,83										
G 2.1/4-11h.	2	65,71	63,00	160 x 40 x 39,0	1.546,70	105 x 22											
G 2.1/2-11h.	2	75,18	72,50	160 x 40 x 39,0	2.324,87	120 x 22											
G 2.3/4-11h.	2	81,53	79,00	160 x 40 x 39,0	2.819,12	120 x 22											
G 3"-11h.	2	87,88	85,50	160 x 40 x 39,0	2.934,13	150 x 25											
G 4"-11h.	2	113,03	110,50	180 x 45 x 44,0	4.450,08	180 x 25											

UNF 3B Ref. M0 **HSS** **DIN 2181 TOL 3B**

Icon	Uds.	D1 mm	L1 x L2 x mm	MO-3B	€
UNF n°4-48-3B	2	2,84	2,35	40x9x2,7	47,27
UNF n°5-44-3B	2	3,17	2,70	45x10x2,7	47,27
UNF n°6-40-3B	2	3,50	2,95	45x16x3,0	45,17
UNF n°10-32-3B	2	4,83	4,10	50x12x4,9	45,17
UNF n°12-28-3B	2	5,49	4,60	50x12x4,9	47,27
UNF 1/4-28-3B	2	6,35	5,50	50x14x4,9	34,47
UNF 5/16-24-3B	2	7,94	6,90	56x22x4,9	36,91
UNF 3/8-24-3B	2	9,52	8,50	63x20x5,5	42,61
UNF 7/16-20-3B	2	11,11	9,90	63x20x6,2	56,57
UNF 1/2-20-3B	2	12,70	11,50	70x22x7,0	57,87

* Disponibles también con rosca izquierda con 100% de recargo sobre los precios tarifados en rosca derecha

BSW Ref. M0 **HSS** **DIN 351** **TOL Clase 2**

Ref. C5 **HSS** **DIN 223**

DIN BS84 55°

BSF Ref. M0 **HSS** **DIN 5157** **TOL ISO 228**

Ref. C5 **HSS** **DIN 223**

DIN BS84 55°

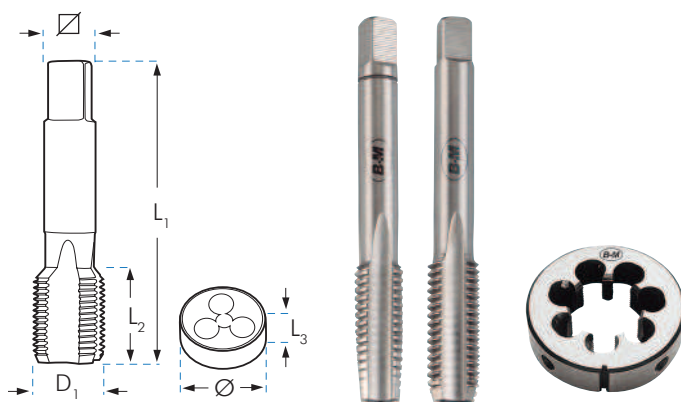

Icon	Uds.	D1 mm	Ø	L1 x L2 x mm	M0		C5	
					€	Ø x L3 mm	€	
W 1/16-60h.	3	1,59	1,15	32x8x2,1	51,14	16x5	68,82	
W 3/32-48h.	3	2,38	1,80	40x9x2,1	37,39	20x5	35,51	
W 1/8-40h.	3	3,17	2,55	40x14x2,7	26,86*	25x9	28,02*	
W 5/32-32h.	3	3,97	3,10	45x17x3,4	27,13	25x9	28,59	
W 3/16-24h.	3	4,76	3,60	50x19x4,9	26,86	25x9	28,02	
W 7/32-24h.	3	5,55	4,40	50x19x4,9	44,17	25x9	36,60	
W 1/4-20h.	3	6,35	5,10	50x20x4,9	30,25*	25x9	28,59*	
W 5/16-18h.	3	7,94	6,50	56x20x4,9	36,95*	25x9	29,82*	
W 3/8-16h.	3	9,52	7,90	63x22x5,5	40,59*	38x10	43,15*	
W 7/16-14h.	3	11,11	9,25	70x22x6,2	54,50	38x10	43,22	
W 1/2-12h.	3	12,70	10,50	75x25x7,0	58,47	38x14	42,40	
W 9/16-12h.	3	14,29	12,00	80x26x9,0	79,55	38x14	51,79	
W 5/8-11h.	3	15,87	13,40	80x27x9,0	91,48*	45x18	61,58*	
W 11/16-11h.	3	17,46	15,25	95x32x11,0	215,57	45x18	101,44	
W 3/4-10h.	3	19,05	16,50	95x32x11,0	130,22*	45x18	61,68*	
W 7/8-9h.	3	22,22	19,25	100x32x14,5	177,85*	55x22	90,69*	
W 1"- 8h.	3	25,40	21,75	110x36x14,5	217,95*	55x22	91,51*	
W 1.1/8-7h.	3	28,57	24,75	125x40x18,0	323,04	65x25	144,10	
W 1.1/4-7h.	3	31,75	27,75	125x40x18,0	390,85	65x25	144,15	
W 1.3/8-6h.	3	34,92	30,50	150x50x22,0	486,05	65x25	146,81	
W 1.1/2-6h.	3	38,10	33,50	150x50x24,0	585,18	75x30	223,17	
W 1.5/8-5h.	3	41,27	46,50	150x56x24,0	814,51	75x30	277,89	
W 1.3/4-5h.	3	44,45	39,00	160x58x29,0	1.002,47	90x36	349,73	
W 1.7/8-4,5h.	3	47,62	42,00	180x65x29,0	1.294,75	90x36	382,67	
W 2"- 4,5h.	3	50,80	44,50	180x65x32,0	1.359,26	90x36	401,06	
W 2.1/4-4h.	3	57,15	50,00	200x85x35,0	2.252,24	105x36		
W 2.1/2-4h.	3	63,50	56,50	220x85x39,0	2.739,90	120x36		
W 2.3/4-3,5h.	3	69,85	62,00	250x90x44,0	3.912,24	120x36		
W 3"- 3,5h.	3	76,20	68,00	250x90x44,0	4.526,03	140x36		

Icon	Uds.	D1 mm	Ø	L1 x L2 x mm	M0		C5	
					€	Ø x L3 mm	€	
BSF 3/16-32h.	2	4,76	4,0	50x19x4,9	101,06	20x7	36,87	
BSF 1/4-26h.	2	6,35	5,2	50x20x4,9	41,11	20x7	40,84	
BSF 5/16-22h.	2	7,94	6,6	56x20x4,9	47,93	25x9	41,29	
BSF 3/8-20h.	2	9,52	8,1	63x22x5,5	55,46	30x11	79,33	
BSF 7/16-18h.	2	11,11	9,5	70x22x6,2	66,56	30x11	78,60	
BSF 1/2-16h.	2	12,70	11,0	75x25x7,0	75,31	38x10	68,59	
BSF 9/16-16h.	2	14,29	12,5	80x26x9,0	90,26	38x10	72,39	
BSF 5/8-14h.	2	15,88	14,0	80x26x9,0	118,11	45x14	112,84	
BSF 3/4-12h.	2	19,05	16,5	95x33x11,0	180,55	45x14	113,88	
BSF 7/8-11h.	2	22,23	19,5	100x33x14,5	215,49	55x22	152,72	
BSF 1"-10h.	2	25,40	22,5	110x40x14,5	302,48	55x22	151,03	
BSF 1.1/8-9h.	2	28,57	25,5	110x40x16,0	682,52			
BSF 1.1/4-9h.	2	31,75	28,5	125x46x18,0	779,24			
BSF 1.1/2-8h.	2	38,10	34,5	150x55x22,0	1.187,59			



BSW **INOX** **TiN**

Icon	Uds.	L1 x L2 x mm	MOT		C5T	
			€	Ø x L3 mm	€	
W 3/16-24 h.	3	50 x 19 x 4,90	51,27	25x9	51,25	
W 1/4-20 h.	3	50 x 20 x 4,90	57,39	25x9	52,19	
W 5/16-18 h.	3	56 x 20 x 4,90	62,88	25x9	54,25	
W 3/8-16 h.	3	63 x 22 x 5,50	74,01	38x10	64,13	
W 1/2-12 h.	3	75 x 25 x 7,00	104,44	38x14	86,16	

* Disponibles también con rosca izquierda con 100% de recargo sobre los precios tarifados en rosca derecha

NPTF

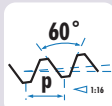

Rosca AMERICANA
Rosca Cónica estanca

Ref. M0





HSS

Ref. C5

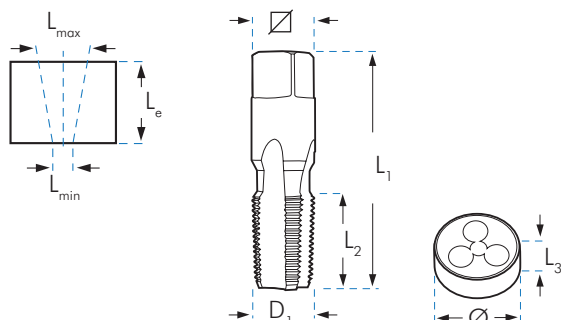
HSS

**DIN
223**



							M0	C5
							€	€
		Uds.	D1 mm		Lmin x Lmax mm	Le mm	L1 x L2 x  mm	Ø x L3 mm
NPTF 1/16-27 h.		1	7,87	6,2	6,00 x 6,41	12,0	54 x 18 x 6,0	25 x 11
NPTF 1/8-27 h.		1	10,22	8,5	8,30 x 8,76	12,0	54 x 19 x 8,0	38 x 10
NPTF 1/4-18 h.		1	13,58	11,0	10,70 x 11,40	17,5	62 x 27 x 11,0	38 x 15
NPTF 3/8-18 h.		1	17,02	14,5	14,20 x 14,84	17,6	65 x 27 x 13,0	45 x 14
NPTF 1/2-14 h.		1	21,21	17,8	17,40 x 18,33	22,8	80 x 35 x 13,0	45 x 20
NPTF 3/4-14 h.		1	26,56	23,0	22,80 x 23,68	23,0	83 x 35 x 17,0	55 x 22
NPTF 1"-11,5 h.		1	33,19	29,0	28,60 x 29,72	27,4	95 x 44 x 21,0	65 x 25

NPT

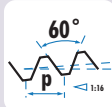

Rosca AMERICANA
Rosca Cónica no estanca (Briggs)

Ref. M0





HSS

Ref. C5

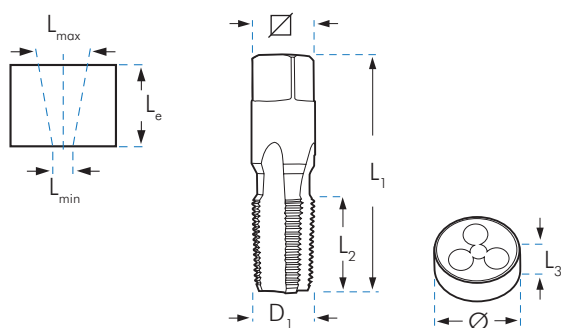
HSS

**DIN
223**



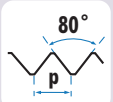

								M0	C5	
								€	€	
		Uds.	D1 mm		Lmin x Lmax mm	Le mm	L1 x L2 x  mm	Ø x L3 mm		
NPT 1/16-27 h.		1	7,89	6,20	EMNPT1/16	6,00 x 6,38	54 x 18 x 6,0	31,29	25 x 9	103,43
NPT 1/8-27 h.		1	10,24	8,50	EMNPT1/8	8,30 x 8,73	54 x 19 x 8,0	31,29	30 x 11	76,47
NPT 1/4-18 h.		1	13,62	11,00	EMNPT1/4	10,70 x 11,35	62 x 27 x 11,0	43,89	38 x 14	76,47
NPT 3/8-18 h.		1	17,05	14,50	EMNPT3/8	14,20 x 14,80	65 x 27 x 13,0	60,57	45 x 18	99,83
NPT 1/2-14 h.		1	21,23	17,80	EMNPT1/2	17,40 x 18,32	80 x 35 x 13,0	84,69	45 x 18	99,83
NPT 3/4-14 h.		1	26,57	23,00	-	22,80 x 23,66	83 x 35 x 17,0	129,49	55 x 22	182,64
NPT 1"-11,5 h.		1	33,23	29,00	-	28,60 x 29,69	95 x 44 x 21,0	144,21	65 x 25	219,56
NPT 1.1/4-11,5 h.		1	41,98	37,50	-	37,40 x 38,45	125 x 33 x 24,0	236,44	75 x 26	272,83
NPT 1.1/2-11,5 h.		1	48,05	44,00	-	43,40 x 44,52	140 x 33 x 29,0	359,28	90 x 27	380,65
NPT 2"-11,5 h.		1	60,09	56,00	-	55,50 x 56,56	160 x 33 x 35,0	560,90	105 x 36	529,96
NPT 2.1/2"-8h.		1	73,03	67,00	-	68,68 x 69,08	200 x 45 x 39,0	685,36		
NPT 3"-8h.		1	88,90	82,00	-	84,45 x 84,86	220 x 48 x 39,0	963,36		

* Ver escariador previo pag.135

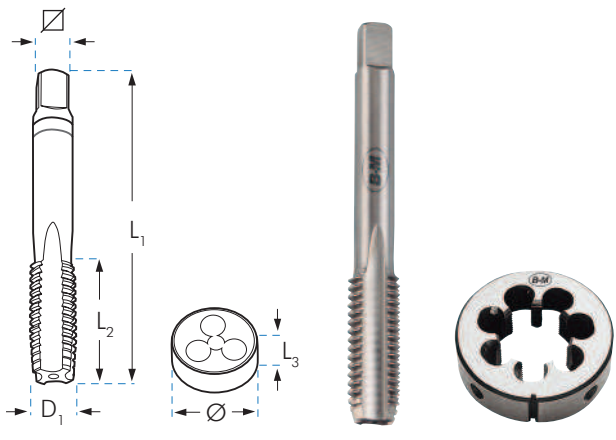

PG  Ref. M0 **HSS** **DIN 40430** Ref. C5 **HSS** **DIN 223**

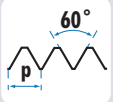

					M0		C5	
		Uds.	D1 mm		L1 x L2 x mm	€	Ø x L3 mm	€
Pg 7	20h.	1	12,5	11,50	70x20x7,0	29,99	38x10	56,75
Pg 9	18h.	1	15,2	14,00	70x20x9,0	38,13	38x10	56,75
Pg 11	18h.	1	18,6	17,25	80x22x11,0	52,94	45x14	71,06
Pg 13,5	18h.	1	20,4	19,00	80x22x12,0	58,06	45x14	71,06
Pg 16	18h.	1	22,5	21,25	80x22x14,5	69,73	55x16	91,68
Pg 21	16h.	1	28,3	27,00	90x22x18,0	102,54	65x18	130,31
Pg 29	16h.	1	37,0	35,50	100x25x22,0	203,61	65x18	130,31
Pg 36	16h.	1	47,0	45,50	140x32x29,0	343,89	90x22	334,01
Pg 42	16h.	1	54,0	52,50	140x36x32,0	408,38	105x22	334,01
Pg 48	16h.	1	59,3	58,00	160x36x35,0	515,04	105x22	442,92

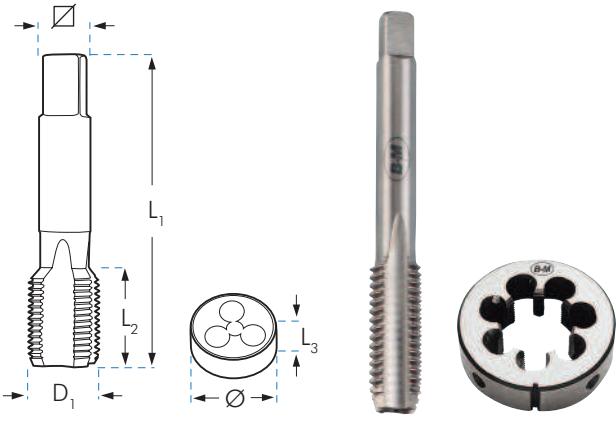

NPSF  Rosca AMERICANA Rosca Cilíndrica estanca Ref. M0 **HSS** Ref. C5 **HSS** **DIN 223**

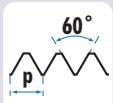

					M0		C5	
		Uds.	D1 mm		L1 x L2 x mm	€	Ø x L3 mm	€
NPSF 1/8-27 h.	1	10,05	8,75	63x18x5,5	124,07	38x10	216,14	
NPSF 1/4-18 h.	1	13,35	11,30	70x20x9,0	179,29	38x10	216,14	
NPSF 3/8-18 h.	1	16,78	14,70	70x20x9,0	247,99	45x14	274,95	
NPSF 1/2-14 h.	1	20,87	18,20	80x22x12,0	324,19	45x14	274,95	
NPSF 3/4-14 h.	1	26,23	23,50	90x22x16,0	493,27	55x16	594,33	
NPSF 1"-11,5 h.	1	32,81	29,50	100x25x20,0				

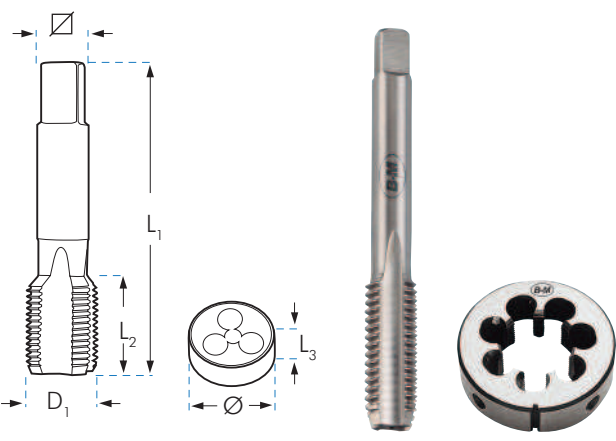
NPS (M)  Rosca AMERICANA Rosca Cilíndrica no estanca Ref. M0 **HSS** Ref. C5 **HSS** **DIN 223**



					M0		C5	
		Uds.	D1 mm		L1 x L2 x mm	€	Ø x L3 mm	€
NPS 1/8-27 h.	1	10,20	8,9	63x18x5,5	102,81	38x10	180,08	
NPS 1/4-18 h.	1	13,60	11,7	70x20x9,0	81,82	38x10	180,08	
NPS 3/8-18 h.	1	17,00	15,0	70x20x9,0	113,16	45x14	229,12	
NPS 1/2-14 h.	1	21,20	18,6	80x22x12,0	147,90	45x14	229,12	
NPS 3/4-14 h.	1	26,55	24,0	90x22x16,0	214,79	55x16	453,88	
NPS 1"-11,5 h.	1	33,20	30,0	100x25x20,0	300,32	65x18	445,48	

BSPT

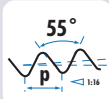

Ref. M0

HSS



DIN 5157

Ref. C5

HSS

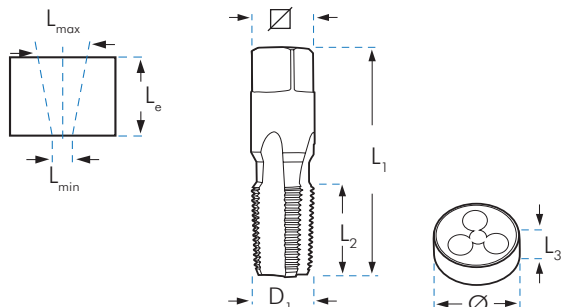
DIN 223



							M0	C5		
							€	€		
		Uds.	D1 mm		L _{min} x L _{max} mm	L _e mm	L ₁ x L ₂ x mm	Ø x L ₃ mm		
BSPT 1/8-28 h.		1	9,73	8,30	8,00 x 8,50	10,1	65 x 19 x 5,5	29,04	30 x 11	93,51
BSPT 1/4-19 h.		1	13,16	11,00	10,70 x 11,35	15,0	70 x 25 x 9,0	40,92	38 x 14	93,51
BSPT 3/8-19 h.		1	16,66	14,50	14,15 x 14,25	15,4	70 x 25 x 9,0	56,84	45 x 16	121,79
BSPT 1/2-14 h.		1	20,95	18,10	17,60 x 18,50	20,5	80 x 31 x 12,0	79,57	55 x 22	121,79
BSPT 5/8-14 h.		1	22,91	20,00	19,50 x 20,40	22,4	80 x 36 x 14,5	139,56	55 x 19	254,12
BSPT 3/4-14 h.		1	26,44	23,50	23,00 x 24,00	21,8	85 x 33 x 16,0	129,85	55 x 22	229,98
BSPT 7/8-14 h.		1	30,20	27,25	26,65 x 28,75	24,0	100 x 36 x 18,0	253,24	65 x 22	332,00
BSPT 1"-11 h.		1	33,25	29,60	29,00 x 30,20	26,0	110 x 38 x 20,0	205,64	65 x 25	265,58

BA

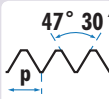

Ref. M0

HSS



DIN 352

Ref. C5

HSS

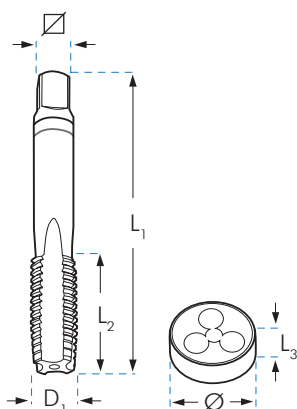
DIN 223



							M0	C5	
							€	€	
		Uds.	D1 mm		L ₁ x L ₂ x mm		Ø x L ₃ mm		
BA-0		1,00	3	6,0	5,1	50 x 18 x 4,9	180,97	20 x 5	144,15
BA-1		0,90	3	5,3	4,5	50 x 18 x 4,9	180,97	20 x 5	144,15
BA-2		0,81	3	4,7	4,0	50 x 17 x 4,9	180,97	20 x 5	144,15
BA-3		0,73	3	4,1	3,4	45 x 14 x 3,4	194,47	20 x 5	144,15
BA-4		0,66	3	3,6	3,0	45 x 14 x 3,0	194,47	20 x 5	144,15
BA-5		0,59	3	3,2	2,6	45 x 14 x 3,0	232,37	20 x 5	144,15
BA-6		0,53	3	2,8	2,3	40 x 12 x 2,7	232,37	20 x 5	144,15
BA-7		0,48	3	2,5	2,0	40 x 10 x 2,1	255,48	20 x 5	144,15
BA-8		0,43	3	2,2	1,8	36 x 10 x 2,1	255,48	20 x 5	144,15

UNx8  Rosca AMERICANA Ref. M0 **HSS** **DIN 2181** **TOL 2B** Ref. C5 **HSS** **DIN 223** **TOL 2a**



UN	Uds.	D1 mm	L1 x L2 x mm	M0		C5	
				€	Ø x L3 mm	€	
UN 1"1/8-8h.	2	28,57	25,40 138x65x17,0	341,26	65x25	380,82	
UN 1"1/4-8h.	2	31,75	28,50 146x65x19,5	442,54	65x25	380,82	
UN 1"3/8-8h.	2	34,92	31,75 154x76x21,0	550,41	65x25	379,16	
UN 1"1/2-8h.	2	38,10	35,00 162x76x23,5	629,90	75x30	429,23	
UN 1"5/8-8h.	2	41,27	38,10 170x80x25,0	783,13	75x30	449,28	
UN 1"3/4-8h.	2	44,45	41,25 178x81x27,0	976,00	90x36	599,05	
UN 1"7/8-8h.	2	47,62	44,45 186x90x29,0	1.217,61	90x36	640,97	
UN 2"-8h.	2	50,80	47,63 194x90x31,5	1.157,59	90x36	648,97	
UN 2"1/4-8h.	2	57,15	54,00 208x90x36,0		120x36		
UN 2"1/2-8h.	2	63,50	60,35 220x100x40		120x36		
UN 2"3/4-8h.	2	69,85	66,70 234x104x39		120x36		
UN 3"-8h.	2	76,20	73,05 248x115x49		120x36		

UNEF  Rosca AMERICANA Ref. M0 **HSS** **DIN 2181** **TOL 2B** Ref. C5 **HSS** **DIN 223** **TOL 2a**



UNEF	Uds.	D1 mm	L1 x L2 x mm	M0		C5	
				€	Ø x L3 mm	€	
UNEF 1/4-32h.	2	6,35	5,55 65x28x4,9	91,72	20x7	94,89	
UNEF 5/16-32h.	2	7,94	7,15 70x30x6,0	102,47	25x9	94,89	
UNEF 3/8-32h.	2	9,52	8,70 75x33x7,0	117,27	30x11	147,33	
UNEF 7/16-28h.	2	11,11	10,20 81x38x6,0	149,28	30x11	147,33	
UNEF 1/2-28h.	2	12,70	11,80 86x44x7,0	168,67	38x10	147,33	
UNEF 9/16-24h.	2	14,29	13,20 92x44x8,0	197,31	38x10	147,33	
UNEF 5/8-24h.	2	15,87	14,80 93x47x9,0	274,65	45x14	236,15	
UNEF 3/4-20h.	2	19,05	17,80 108x52x11,0	406,69	45x14	236,15	
UNEF 7/8-20h.	2	22,22	20,95 120x58x13,0	678,89	55x16	313,43	
UNEF 1"-20h.	2	25,40	24,20 130x65x15,0	581,92	55x16	288,61	



Ref. M0MD

HSSCo
5%

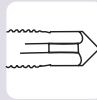

DIN
352

OX

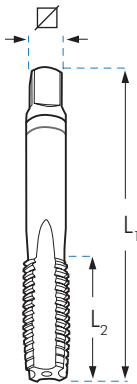

ESPECIAL MATERIALES DUROS
(≤ 1100 N/mm²=40HRc)



				M0MD	
	Uds.		L1 x L2 x ∇ mm	€	
M 3 x 0,50	3	2,50	40 x 11 x 2,7	31,68	
M 4 x 0,70	3	3,30	45 x 13 x 3,4	31,68	
M 5 x 0,80	3	4,20	50 x 17 x 4,9	32,71	
M 6 x 1,00	3	5,00	50 x 19 x 4,9	33,67	
M 8 x 1,25	3	6,80	56 x 20 x 4,9	38,28	
M 10 x 1,50	3	8,50	70 x 22 x 5,5	49,14	
M 12 x 1,75	3	10,20	75 x 24 x 7,0	70,36	
M 14 x 2,00	3	12,00	80 x 26 x 9,0	83,29	
M 16 x 2,00	3	14,00	80 x 27 x 9,0	110,66	
M 18 x 2,50	3	15,50	95 x 30 x 11,0	170,18	
M 20 x 2,50	3	17,50	95 x 32 x 12,0	188,95	

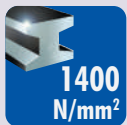

Ref. M0C



HSS
PM

TiAlSiN

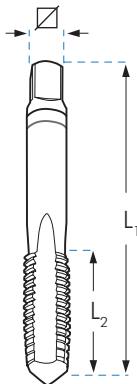

ESPECIAL MATERIALES MUY DUROS
(≤ 1400 N/mm²=44HRc)



				M0C	
	Uds.		L1 x L2 x ∇ mm	€	
M 3 x 0,50	3	2,50	40 x 11 x 2,7	83,36	
M 4 x 0,70	3	3,30	45 x 13 x 3,4	89,94	
M 5 x 0,80	3	4,20	50 x 17 x 4,9	91,07	
M 6 x 1,00	3	5,00	50 x 19 x 4,9	91,07	
M 8 x 1,25	3	6,80	56 x 20 x 4,9	102,65	
M 10 x 1,50	3	8,50	70 x 22 x 5,5	126,88	
M 12 x 1,75	3	10,20	75 x 24 x 7,0	154,25	
M 14 x 2,00	3	12,00	80 x 26 x 9,0	189,26	
M 16 x 2,00	3	14,00	80 x 27 x 9,0	226,77	
M 18 x 2,50	3	15,50	95 x 30 x 11,0	314,40	
M 20 x 2,50	3	17,50	95 x 32 x 12,0	346,03	

AI

Ref. M0AL

HSS

BRILLANTE

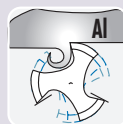

ESPECIAL ALUMINIO

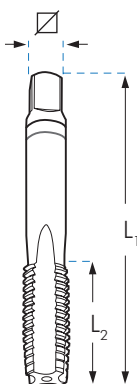

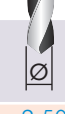
				M0AL	
	Uds.		L1 x L2 x ∇ mm	€	
M 3 x 0,50	3	2,50	40 x 11 x 2,7	26,06	
M 4 x 0,70	3	3,30	45 x 13 x 3,4	25,31	
M 5 x 0,80	3	4,20	50 x 17 x 4,9	26,82	
M 6 x 1,00	3	5,00	50 x 19 x 4,9	26,82	
M 8 x 1,25	3	6,80	56 x 20 x 4,9	32,92	
M 10 x 1,50	3	8,50	70 x 22 x 5,5	40,19	
M 12 x 1,75	3	10,20	75 x 24 x 7,0	56,58	
M 14 x 2,00	3	12,00	80 x 26 x 9,0	65,03	
M 16 x 2,00	3	14,00	80 x 27 x 9,0	92,30	
M 18 x 2,50	3	15,50	95 x 30 x 11,0	122,33	
M 20 x 2,50	3	17,50	95 x 32 x 12,0	137,90	

M

INOX

Ref. MOT
Ref. MOX

DIN 352

TOL 6H

TiN

Ref. C5T
Ref. C5X

DIN 223

TOL 6g

OX

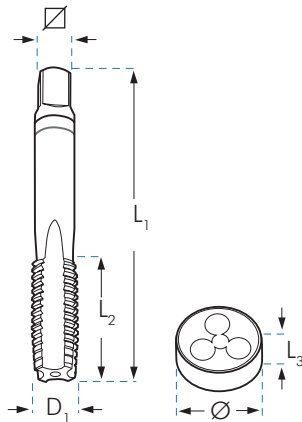

M

	Uds.	L1 x L2 x ∇ mm	MOT	C5T	MOX	C5X	Ø x L3 mm
			HSS	HSS	HSSCo	HSSCo	
			TiN	TiN	OX	OX	
			€	€	€	€	
M 2 x 0,40	3	36 x 9 x 2,10					
M 3 x 0,50	3	40 x 11 x 2,70	37,33	55,91	31,42	21,47	20 x 5
M 4 x 0,70	3	45 x 13 x 3,40	39,22	55,91	31,42	21,47	20 x 5
M 5 x 0,80	3	50 x 16 x 4,90	41,60	55,91	32,70	24,10	20 x 7
M 6 x 1,00	3	50 x 19 x 4,90	41,60	55,91	32,61	24,45	20 x 7
M 8 x 1,00	2	50 x 19 x 4,90	36,57				
M 8 x 1,25	3	56 x 22 x 4,90	47,99	57,32	37,95	26,52	25 x 9
M 10 x 1,00	2	63 x 18 x 5,50	42,20				
M 10 x 1,50	3	70 x 24 x 5,50	63,90	75,25	48,82	33,65	30 x 11
M 12 x 1,50	2	70 x 20 x 7,00	53,73				
M 12 x 1,75	3	75 x 29 x 7,00	74,15	83,44	69,91	35,54	38 x 14
M 14 x 1,50	2	70 x 20 x 9,00	64,52				
M 14 x 2,00	3	80 x 30 x 9,00	89,67	83,44	77,42	35,54	38 x 14
M 16 x 2,00	3	80 x 32 x 9,00	112,60	102,83	106,11	47,72	45 x 18
M 18 x 2,50	3	95 x 40 x 11,00	139,59		144,91		
M 20 x 2,50	3	95 x 40 x 12,00	144,75		160,84		
M 22 x 2,50	3	100 x 40 x 14,50	183,10				
M 24 x 3,00	3	110 x 50 x 14,50	220,64				

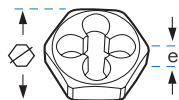

M HSS DIN 382

C5HM			C5HM		
		€			€
M 3 x 0,35	18 x 5		M 16 x 2,00	41 x 18	99,41
M 3 x 0,50	19 x 5	36,18	M 18 x 1,00	41 x 14	99,41
M 3,5 x 0,60	18 x 5	36,18	M 18 x 1,50	41 x 14	99,41
M 4 x 0,50	18 x 5	36,18	M 18 x 2,50	41 x 18	99,41
M 4 x 0,70	19 x 5	36,18	M 20 x 1,00	41 x 14	99,41
M 5 x 0,50	18 x 5	36,18	M 20 x 1,50	41 x 14	99,41
M 5 x 0,75	18 x 5	36,18	M 20 x 2,00	41 x 18	99,41
M 5 x 0,80	19 x 7	36,18	M 20 x 2,50	41 x 18	99,41
M 6 x 0,75	18 x 7	36,18	M 22 x 1,00	50 x 16	125,70
M 6 x 1,00	19 x 7	36,18	M 22 x 1,50	50 x 16	125,70
M 7 x 0,75	21 x 9	36,18	M 22 x 2,00	50 x 16	125,70
M 7 x 1,00	21 x 9	38,45	M 22 x 2,50	50 x 16	125,70
M 8 x 0,75	21 x 9	38,45	M 24 x 1,00	50 x 16	202,84
M 8 x 1,00	21 x 9	38,45	M 24 x 1,50	50 x 16	202,84
M 8 x 1,25	22 x 9	38,45	M 24 x 2,00	50 x 16	202,84
M 9 x 0,75	21 x 9	38,45	M 24 x 3,00	50 x 22	125,70
M 9 x 1,00	21 x 9	45,27	M 27 x 1,50	60 x 18	169,95
M 9 x 1,25	22 x 9	45,27	M 27 x 2,00	60 x 18	169,95
M 10 x 1,00	27 x 11	45,27	M 27 x 3,00	60 x 25	141,62
M 10 x 1,25	27 x 11	45,27	M 30 x 1,00	60 x 18	169,95
M 10 x 1,50	27 x 11	45,27	M 30 x 1,50	60 x 18	169,95
M 11 x 1,00	27 x 11	45,27	M 30 x 2,00	60 x 18	169,95
M 11 x 1,50	27 x 11	45,27	M 30 x 3,00	60 x 18	169,95
M 12 x 1,25	36 x 10	75,42	M 30 x 3,50	60 x 25	141,62
M 12 x 1,50	36 x 10	75,42	M 33 x 1,50	60 x 18	190,30
M 12 x 1,75	36 x 10	75,42	M 33 x 2,00	60 x 18	190,30
M 14 x 1,25	36 x 14	63,37	M 33 x 3,50	60 x 25	158,58
M 14 x 1,50	36 x 10	63,37	M 35 x 1,50	60 x 18	196,18
M 14 x 2,00	36 x 10	85,71	M 36 x 1,50	60 x 18	196,18
M 15 x 1,00	36 x 14	85,71	M 36 x 2,00	60 x 18	196,18
M 15 x 1,50	41 x 14	63,37	M 36 x 3,00	60 x 18	196,18
M 16 x 1,00	41 x 14	99,41	M 36 x 4,00	60 x 25	163,49
M 16 x 1,50	41 x 14	99,41			
		99,41			
		99,41			

BSW HSS DIN 382

C5HW			C5HW		
		€			€
BSW 1/8 x 40h.	19 x 5		BSW 9/16 x 12h.	36 x 14	67,90
BSW 3/16 x 24h.	19 x 7		BSW 5/8 x 11h.	41 x 18	100,35
BSW 1/4 x 20h.	19 x 7	45,27	BSW 3/4 x 10h.	41 x 18	100,35
BSW 5/16 x 18h.	22 x 9	45,27	BSW 7/8 x 9h.	50 x 22	147,07
BSW 3/8 x 16h.	27 x 11	45,27	BSW 1" x 8h.	50 x 22	147,07
BSW 7/16 x 14h.	27 x 11	47,52	BSW 1.1/8 x 7h.	60 x 25	253,50
BSW 1/2 x 12h.	36 x 14	56,56			
		56,56			
		67,90			

BSP (GAS) HSS DIN 382

C5HG		
		€
G 1/8 x 28h.	27 x 11	79,66
G 1/4 x 19h.	36 x 10	79,66
G 3/8 x 19h.	41 x 14	99,62
G 1/2 x 14h.	41 x 14	99,62
G 5/8 x 14h.	50 x 16	234,57
G 3/4 x 14h.	50 x 16	234,57
G 7/8 x 14h.	60 x 18	236,65
G 1" x 11h.	60 x 18	236,65
G1.1/4 x 11h.	70 x 20	315,54
G1.1/2 x 11h.	85 x 22	532,33
G 2" x 11h.	100 x 22	801,03

UNC HSS DIN 382

C5HNC		
		€
UNC 1/4-20h	18 x 7	
UNC 5/16-18h	21 x 9	32,99
UNC 3/8-16h	27 x 11	41,06
UNC 7/16-14h	27 x 11	49,56
UNC 1/2-13h	36 x 14	73,13
UNC 9/16-12h	36 x 14	73,41
UNC 5/8-11h	41 x 18	87,72
UNC 3/4-10h	41 x 18	67,97
UNC 7/8-9h	50 x 22	108,11
UNC 1"-8h	50 x 22	153,42
UNC 1.1/8-7h	60 x 25	153,42
UNC 1.1/4-7h	60 x 25	202,84
		202,84

UNF HSS DIN 382

C5HNF		
		€
UNF 1/4-28h.	18 x 7	
UNF 3/16-24h.	21 x 9	
UNF 3/8-24h.	27 x 11	34,98
UNF 7/16-20h.	27 x 11	43,72
UNF 1/2-20h.	36 x 10	52,61
UNF 9/16-18h.	36 x 10	77,51
UNF 5/8-18h.	41 x 14	78,70
UNF 3/4-16h.	41 x 14	87,72
UNF 7/8-14h.	50 x 16	109,43
UNF 1"-12h.	50 x 16	114,61
UNF 1"-14h.	50 x 16	144,94
UNF 1.1/8-12h.	60 x 18	151,95
UNF 1.1/4-12h.	60 x 18	151,95
		202,84
		202,84



	TIPOS DE ROSCA	RANGO DE PASOS		GAM
		Métricos	Ingleses	€
GAM	Pasos rosca métrica	0,25 - 2,5		10,22
GAMW	Pasos rosca métrica /rosca Inglesa	0,25 - 6,0	62h - 4h	18,51

CONJUNTO DE GUIAS PARA COJINETES M3-M12

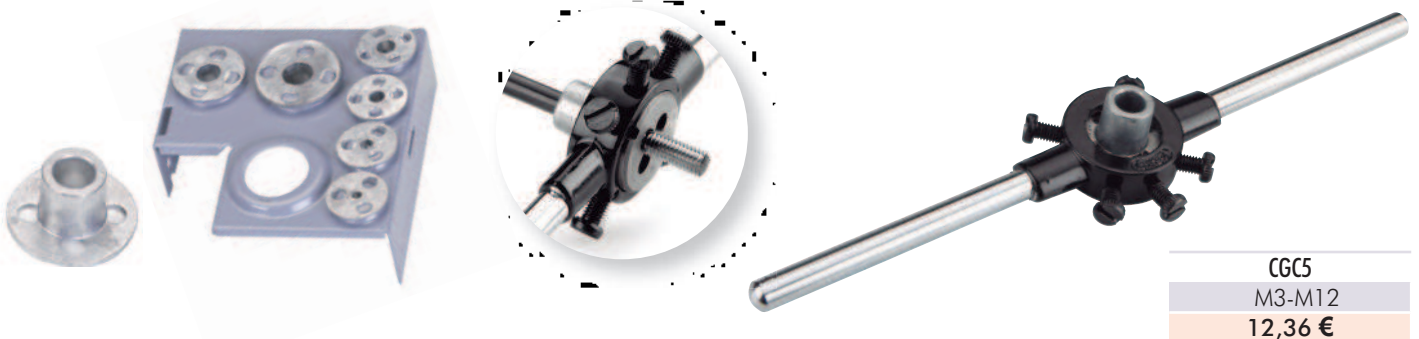

CG5
M3-M12
12,36 €

ALARGADOR DE MACHOS

DIN 377

DIN 10

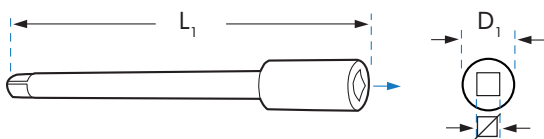

	∅ x L1 mm	D1	AL €
AL21	2,1 x 60	6,0	7,54
AL24	2,4 x 70	6,0	7,54
AL27	2,7 x 80	7,0	7,54
AL30	3,0 x 90	7,0	7,54
AL34	3,4 x 95	8,0	8,17
AL38	3,8 x 95	9,0	8,53
AL43	4,3 x 105	10,0	9,50
AL49	4,9 x 110	11,0	9,17
AL55	5,5 x 115	12,0	9,32
AL62	6,2 x 120	14,0	11,66
AL70	7,0 x 125	15,0	12,15
AL80	8,0 x 125	17,0	15,18
AL90	9,0 x 135	19,0	15,58

	∅ x L1 mm	D1	AL €
AL100	10,0 x 140	21,0	21,53
AL110	11,0 x 150	23,0	21,84
AL120	12,0 x 160	25,0	23,51
AL130	13,0 x 165	27,0	36,78
AL145	14,5 x 175	29,0	37,29
AL160	16,0 x 185	30,0	39,45
AL180	18,0 x 195	33,0	44,97
AL200	20,0 x 220	36,0	59,96
AL220	22,0 x 220	40,0	87,64
AL240	24,0 x 235	42,0	134,22
AL260	26,0 x 245	45,0	141,74
AL290	29,0 x 260	55,0	163,52
AL320	32,0 x 280	55,0	201,31

Ref. GAPRO **DIN 1814**

- Cuerpo de Acero Forjado.
- Soporta esfuerzos hasta 150 kg/mm².
- Máxima resistencia y durabilidad.

- Mayor precisión y firmeza en el amarre.
- Su rosca de precisión conforma un conjunto sólido y robusto.
- Maneral antideslizante, mayor agarre en el taller.



GAPRO

Nº NORMA	Nº 0	Nº 1	Nº 1.1/2	Nº 2	Nº 3	Nº 4	Nº 5
	M1-M8 2,00-5,00	M1-M10 2,00-6,30	M1-M12 2,50-7,00	M1-M12 2,50-8,00	M5-M20 4,00-13,00	M5-M27 4,00-16,00	M9-M32 5,50-20,00
€	18,20	19,23	20,43	25,82	36,54	58,42	123,65

Ref. GA **DIN 1814**

- Cuerpo de Aleación de Zinc.
- Alta resistencia y durabilidad.
- Alta precisión y firmeza en el amarre.



GA

Nº NORMA	Nº 0	Nº 1	Nº 1.1/2	Nº 2	Nº 3	Nº 4	Nº 5	Nº 7	Nº 8
	M1-M8 1,50-5,00	M1-M10 2,00-7,00	M1-M12 2,00-8,00	M4-M12 2,50-10,00	M5-M20 3,50-14,00	M9-M27 4,00-15,00	M13-M32 5,50-19,00	M22-M56 14,00-31,50	M33-M64 16,00-40,00
€	15,29	16,16	17,17	21,69	30,70	49,10	103,91	211,25	335,36

VOLVEDORES PARA TERRAJAS DE ROSCAR

Ref. VA **DIN 225**



IMPORTANTE: A la hora de cursar sus pedidos de volvedores, indiquen el espesor del volvedor que corresponda, según detalle de espesores que indicamos en la tarifa de terrajas.

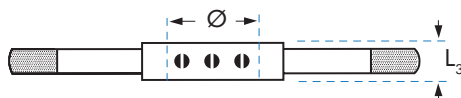

	VA												
Ø x L3 mm	16x5	20x5	20x7	25x9	30x11	38x10	38x14	45x14	45x18	55x16	55x22	65x18	65x25
€	8,48	9,40	9,40	10,73	12,99	16,99	16,97	20,85	21,01	26,95	28,23	38,63	38,63
Ø x L3 mm	75x20	75x30	90x22	90x36	105x22	105x36	120x22	120x36	130x25	130x36	140x25	140x36	
€	66,93	70,06	84,78	91,34	126,14	126,14	328,05	328,05	341,05	341,05	358,64	358,64	

Ref. VA **PULGADAS**



	VA						
Ø mm	20,60	25,40	38,10	50,80	63,50	76,20	88,90
PULGADAS	13/16"	1"	1.1/2"	2"	2.1/2"	3"	3.1/2"
€	9,21	10,92	16,34	24,24	38,25	70,74	89,61

NOTA: Los volvedores para terrajas en Ø exteriores en pulgadas, están en desuso.

Ref. TC **TIPO T**  SERIE CORTA



	CAPACIDAD mm mín.-máx.	Para mangos de machos		L ₁ mm	PESO g	CALIDAD	TC
		DIN	ISO				€
TC3B	2,6 - 5,5	M3 - 8	M3 - 6	85	180	1ª Calidad	24,98
TC4B	4,6 - 8,0	M5 - 12	M6 - 12	110	300	1ª Calidad	33,73
TC1B	2,6 - 5,5	M3 - 8	M3 - 6	85	180	2ª Calidad	18,91
TC2B	4,6 - 8,0	M5 - 12	M6 - 12	110	300	2ª Calidad	25,36



Ref. TL **TIPO T** SERIE LARGA

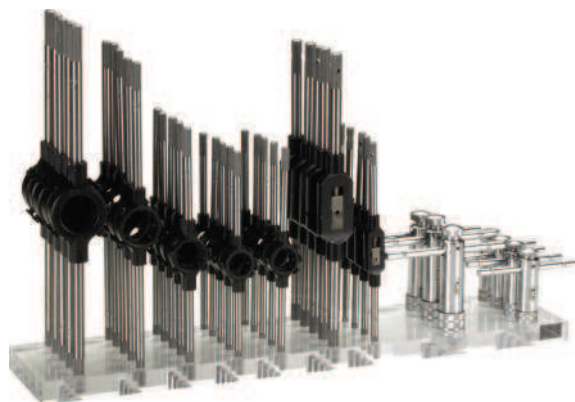

	CAPACIDAD mm mín.-máx.	Para mangos de machos		L ₁ mm	PESO g	CALIDAD	TL
		DIN	ISO				€
TL3	2,6 - 5,5	M3 - 8	M3 - 6	250	250	1ª Calidad	37,98
TL4	4,6 - 8,0	M5 - 12	M6 - 12	300	440	1ª Calidad	45,22
TL1	2,6 - 5,5	M3 - 10	M3 - 6	250	250	2ª Calidad	29,99
TL2	4,6 - 8,0	M5 - 12	M6 - 12	300	440	2ª Calidad	35,74

EXPOSITOR DE METACRILATO



								GV-01
								€
GV-01	Nº 1 5	Nº 2 5	20 x 5 5	20 x 7 5	25 x 9 5	TC1 4	TC2 4	657,70



M3
M12

HSS

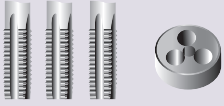

Ref. D624

CONTENIDO

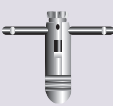
					Nº Piezas	1ª Calidad €	2ª Calidad €
D624	M3 - M4 - M5 - M6 - M8 - M10 - M12	Nº 1.1/2	25 x 9	-	30	219,03	198,69

CONJUNTOS DE COJINETES EN CAJA METÁLICA HSS



M3
M12

HSS



Ref. D671

CONTENIDO

					Nº Piezas	1ª Calidad €	2ª Calidad €
D671	M3 - M4 - M5 - M6 - M8 - M10 - M12	20 x 5 30 x 11	20 x 7 38 x 14	25 x 9	12	216,06	183,00
D671I (Izq)	 M3 - M4 - M5 - M6 - M8 - M10 - M12	20 x 5 30 x 11	20 x 7 38 x 14	25 x 9	12	432,10	365,98

M3
M12



HSS

HSSCo
5%



Ref. D621



Ref. D655

CONTENIDO

							Nº Piezas	1ª Calidad €	2ª Calidad €
D621	M3 - M4 - M5 - M6 M8 - M10 - M12		2.5 / 3.3 / 4.2 / 5.0 6.8 / 8.5 / 10.2 mm	Nº 1 Nº 2	20 x 5 20 x 7 25 x 9 30 x 11 38 x 14	TC1	43	439,19	321,91
D652	M3 - M4 - M5 - M6 M8 - M10 - M12		2.5 / 3.3 / 4.2 / 5.0 6.8 / 8.5 / 10.2 mm	Nº 1 Nº 2	20 x 5 20 x 7 25 x 9 30 x 11 38 x 14	-	42	425,13	305,70
D662	M3-M4-M5-M6-M7 M8-M9-M10-M11-M12		-	Nº 1 Nº 2	20 x 5 20 x 7 25 x 9 30 x 11 38 x 14	TC1	48	654,26	575,48
D651	M3 - M4 - M5 - M6 M8 - M10 - M12		-	Nº 1 Nº 2	20 x 5 20 x 7 25 x 9 30 x 11 38 x 14	-	35	335,55	308,69
D655* (HSSCo)	M3 - M4 - M5 - M6 M8 - M10 - M12		2.5 / 3.3 / 4.2 / 5.0 6.8 / 8.5 / 10.2 mm	Nº 1 Nº 2	20 x 5 20 x 7 25 x 9 30 x 11 38 x 14	TC1	43	700,63	616,28
D621I (Izq)	M3 - M4 - M5 - M6 M8 - M10 - M12		2.5 / 3.3 / 4.2 / 5.0 6.8 / 8.5 / 10.2 mm	Nº 1 Nº 2	20 x 5 20 x 7 25 x 9 30 x 11 38 x 14	TC1	43	685,92	598,19

*

HSSCo
5%



M3
M12



HSS

HSSCo
5%

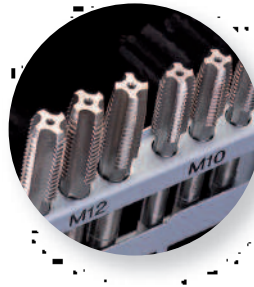







Ref. D656

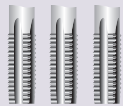

Ref. D657

CONTENIDO

							Nº Piezas	1ª Calidad €	2ª Calidad €
D656	M3 - M4 - M5 - M6 M8 - M10 - M12		2.5 / 3.3 / 4.2 / 5.0 6.8 / 8.5 / 10.2 mm	Nº 1 Nº 2	20 x 5 20 x 7 25 x 9 30 x 11 38 x 14	TC1	43	490,79	434,46
D657* (HSSCo)	M3 - M4 - M5 - M6 M8 - M10 - M12		2.5 / 3.3 / 4.2 / 5.0 6.8 / 8.5 / 10.2 mm	Nº 1 Nº 2	20 x 5 20 x 7 25 x 9 30 x 11 38 x 14	TC1	43	730,62	644,86

*

HSSCo
5%



M3
M20

M5
M20

HSS

HSSCo
5%



Ref. D622



Ref. D623

CONTENIDO

						Nº Piezas	1ª Calidad €	2ª Calidad €
D622	M3 - M4 - M5 - M6 - M8 - M10 - M12 M14 - M16 - M18 - M20	Nº 1 Nº 3	20 x 5 20 x 7 25 x 9 30 x 11 38 x 14 45 x 18	TC1 TC2	54	751,17	590,19	
D658	M3 - M4 - M5 - M6 - M8 - M10 - M12 M14 - M16 - M18 - M20	Nº 1 Nº 3	20 x 5 20 x 7 25 x 9 30 x 11 38 x 14 45 x 18	-	52	692,01	533,95	
D622I (Izq)	M3 - M4 - M5 - M6 - M8 - M10 - M12 M14 - M16 - M18 - M20	Nº 1 Nº 3	20 x 5 20 x 7 25 x 9 30 x 11 38 x 14 45 x 18	TC1 TC2	54	1.293,58	1.226,46	
D659* (HSSCo)	M3 - M4 - M5 - M6 - M8 - M10 - M12 M14 - M16 - M18 - M20	Nº 1 Nº 3	20 x 5 20 x 7 25 x 9 30 x 11 38 x 14 45 x 18	-	52	1.560,35	1.372,48	
D623	M5 - M6 - M8 - M10 - M12 M14 - M16 - M18 - M20	Nº 1 Nº 3	20 x 7 25 x 9 30 x 11 38 x 14 45 x 18	TC1 TC2	45	787,56	616,58	
D663	M5 - M6 - M7 - M8 - M9 - M10 - M12 M14 - M16 - M18 - M20	Nº 1 Nº 3	20 x 7 25 x 9 30 x 11 38 x 14 45 x 18	-	51	1.049,99	944,44	

* HSSCo 5%

M1
M10

M5
M12

M3
M24

M5
M30

HSS



Ref. D628



Ref. D626

CONTENIDO

					Nº Piezas	1ª Calidad €	2ª Calidad €
D626	M1 - M1.2 - M1.4 - M1.7 - M2.0 - M2.3 M2.6 - M3 - M3.5 - M4 - M5 - M6 - M8 - M10	Nº 0 Nº 1	16 x 5 20 x 5 20 x 7 25 x 9 30 x 11	TC1	64		982,46
D627	M5 - M6 - M7 - M8 - M9 - M10 - M11 - M12	Nº 1 Nº 2	20 x 7 25 x 9 30 x 11 38 x 14	TC1	39		733,94
D625	M3 - M4 - M5 - M6 - M8 - M10 - M12 - M14 M16 - M18 - M20 - M22 - M24	Nº 1 Nº 4	20 x 5 20 x 7 25 x 9 30 x 11 38 x 14 45 x 18 55 x 22	-	61	1.733,49	1.279,03
D628	M5 - M6 - M8 - M10 - M12 - M14 - M16 M18 - M20 - M22 - M24 - M27 - M30	Nº 1 Nº 3 Nº 5	20 x 7 25 x 9 30 x 11 38 x 14 45 x 18 55 x 22 65 x 25	-	62		2.341,12

MF

HSS







Ref. D634



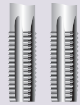



Ref. D636

CONTENIDO

						Nº Piezas	1ª Calidad €	2ª Calidad €
D634	MF 3 x 0.35 - 4 x 0.5 - 5 x 0.5 MF 6 x 0.75 - 8 x 0.75 - 8 x 1.0 MF 10 x 1.0 - 12 x 1.5		Nº 1 Nº 2	20 x 5 25 x 9 30 x 11 38 x 10		TC1	31	673,37
D635	MF 6 x 0.75 - 8 x 0.75 - 8 x 1.0 - 10 x 1.0 MF 12 x 1.0 - 12 x 1.5 - 14 x 1.25 - 14 x 1.5 MF 16 x 1.5 - 18 x 1.5 - 20 x 1.5		Nº 1 Nº 3	20 x 7 25 x 9 30 x 11 38 x 10 45 x 14		-	40	1.098,40 1.044,50
D636	MF 6 x 0.75 - 8 x 0.75 - 8 x 1.0 - 10 x 1.0 MF 12 x 1.0 - 12 x 1.5 - 14 x 1.25 - 14 x 1.5 MF 16 x 1.5 - 18 x 1.5 - 20 x 1.5 - 22 x 1.5 MF 24 x 1.5		Nº 1 Nº 4	20 x 7 25 x 9 30 x 11 38 x 10 45 x 14 55 x 16		-	47	1.506,80 1.393,14

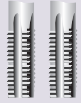



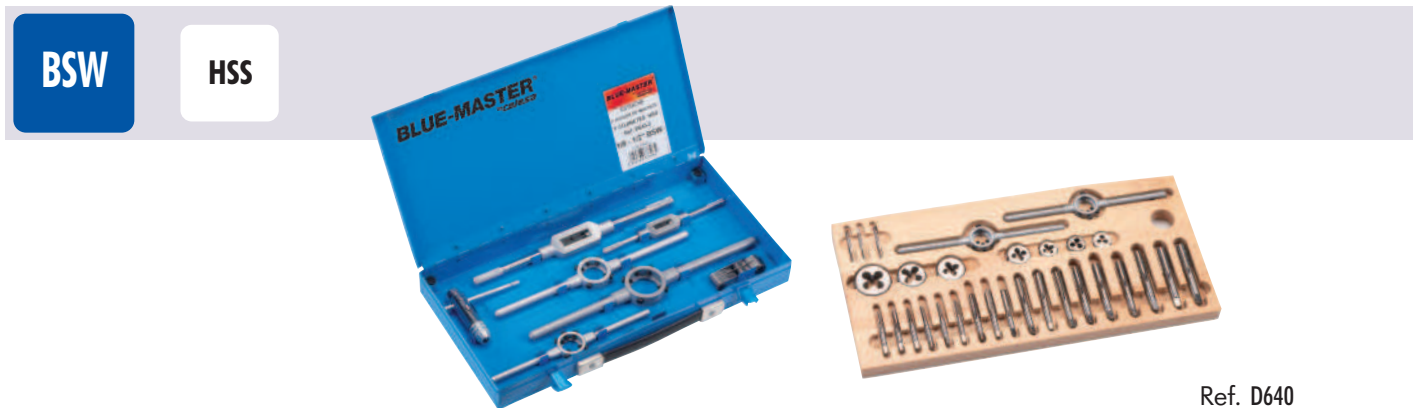

CONTENIDO

						Nº Piezas	1ª Calidad €	2ª Calidad €
D637	G 1/8 - 1/4 - 3/8 - 1/2 - 3/4 - 1"		Nº 1 Nº 3 Nº 5	30 x 11 38 x 10 45 x 14 55 x 16 65 x 18	-	26	1.219,57	985,15
D638	G 1/8 - 1/4 - 3/8 - 1/2 - 5/8 - 3/4 - 7/8 - 1"		Nº 1 Nº 3 Nº 5	30 x 11 38 x 10 45 x 14 55 x 16 65 x 18	-	32	1.655,08	1.444,76
D639	G 1/4 - 3/8 - 1/2 - 3/4 - 1" - 1".1/4 - 1".1/2		Nº 2 Nº 4 Nº 7	38 x 10 45 x 14 55 x 16 65 x 18 75 x 20 90 x 22	-	30	3.053,34	2.575,61

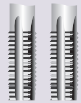

CONTENIDO

						Nº Piezas	1ª Calidad €	2ª Calidad €
D640	BSW 1/8 - 3/16 - 1/4 - 5/16 - 3/8 - 7/16 - 1/2		Nº 1 Nº 2	20 x 5 20 x 7 25 x 9 30 x 11 38 x 14	TC1	36	680,35	581,59
D641	BSW 1/4 - 5/16 - 3/8 - 7/16 - 1/2		Nº 1 Nº 2	20 x 7 25 x 9 30 x 11 38 x 14	TC1	27	560,86	472,40
D642	BSW 1/4 - 5/16 - 3/8 - 7/16 - 1/2 - 5/8 - 3/4		Nº 1 Nº 3	20 x 7 25 x 9 30 x 11 38 x 14 45 x 18	-	35	1.003,74	915,87
D643	BSW 1/4 - 5/16 - 3/8 - 7/16 1/2 - 5/8 - 3/4 - 7/8 - 1"		Nº 1 Nº 4	20 x 7 25 x 9 30 x 11 38 x 14 45 x 18 55 x 22	-	44	1.419,51	1.246,27
D646	BSW 1/4 - 5/16 - 3/8 - 7/16 1/2 - 5/8 - 3/4 - 7/8 - 1" - 1".1/8 1".1/4 - 1".3/8 - 1".1/2		Nº 1 Nº 3 Nº 5	20 x 7 25 x 9 30 x 11 38 x 14 45 x 18 55 x 22 65 x 25	-	62		3.787,14

BSF

HSS



Ref. D648

CONTENIDO

						Nº Piezas	1ª Calidad €	2ª Calidad €	
D664	BSF 1/4 - 5/16 - 3/8 - 7/16 - 1/2		Nº 1 Nº 2	20 x 7 25 x 9 30 x 11 38 x 10		TC1	22	627,20	551,68
D648	BSF 1/4 - 5/16 - 3/8 - 7/16 - 1/2 - 5/8 - 3/4		Nº 1 Nº 3	20 x 7 25 x 9 30 x 11 38 x 10 45 x 14		-	28	973,67	915,87
D665	BSF 1/4 - 5/16 - 3/8 - 7/16 1/2 - 5/8 - 3/4 - 7/8 - 1"		Nº 1 Nº 4	20 x 7 25 x 9 30 x 11 38 x 10 45 x 14 55 x 16		-	35	1.652,14	1.453,21

BSW
BSF

HSS



Ref. D666

CONTENIDO

						Nº Piezas	1ª Calidad €	2ª Calidad €	
D666	BSW 1/4 - 5/16 - 3/8 - 7/16 - 1/2 - 5/8 - 3/4 BSF 1/4 - 5/16 - 3/8 - 7/16 - 1/2 - 5/8 - 3/4		Nº 1 Nº 3	20 x 7 25 x 9 30 x 11 38 x 14 45 x 18		-	63	1.866,31	1.641,59





NPT

HSS



Ref. D660

CONTENIDO

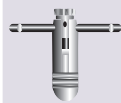
						Nº Piezas	1ª Calidad €	2ª Calidad €
D660	NPT 1/8 - 1/4 - 3/8 - 1/2 - 3/4 - 1"		Nº1 Nº3 Nº5	30 x 11 38 x 14 45 x 18 55 x 22 65 x 25	-	20	1.764,15	1.673,38
D661	NPT 1/8 - 1/4 - 3/8 - 1/2 - 3/4 1" - 1".1/4 - 1".1/2 - 2"		Nº 2 Nº 4 Nº 7	30 x 11 38 x 14 45 x 18 55 x 22 65 x 25 75 x 30 90 x 36 105 X 36	-	29	5.280,96	4.961,44





UNC

HSS

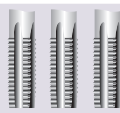

Ref. D650

CONTENIDO

						Nº Piezas	1ª Calidad €	2ª Calidad €
D650	UNC 1/4 - 5/16 - 3/8 - 7/16 - 1/2		Nº 1 Nº 2	20 x 7 25 x 9 30 x 11 38 x 14	TC1	27	683,62	613,58
D667	UNC 1/4 - 5/16 - 3/8 - 7/16 - 1/2 - 5/8 - 3/4		Nº 1 Nº 2	20 x 7 25 x 9 30 x 11 38 x 14 45 x 18	-	35	1.101,43	968,80
D654	UNC 1/4 - 5/16 - 3/8 - 7/16 1/2 - 5/8 - 3/4 - 7/8 - 1"		Nº 1 Nº 4	20 x 7 25 x 9 30 x 11 38 x 14 45 x 18 55 x 22	-	44	1.777,26	1.663,29
D668	UNC 1/4 - 5/16 - 3/8 - 7/16 - 1/2 - 5/8 - 3/4 7/8 - 1" - 1.1/8 - 1".1/4 - 1".3/8 - 1".1/2"		Nº 1 Nº 3 Nº 6	20 x 7 25 x 9 30 x 11 38 x 14 45 x 18 55 x 22 65 x 25	-	62	4.160,95	3.659,94





UNF

HSS



Ref. D644

CONTENIDO

					Nº Piezas	1ª Calidad €	2ª Calidad €
D644	UNF 1/4 - 5/16 - 3/8 - 7/16 - 1/2	Nº 1 Nº 2	20 x 7 25 x 9 30 x 11 38 x 10	TC1	22	535,68	464,39
D669	UNF 1/4-5/16 -3/8 -7/16 -1/2 -5/8 -3/4	Nº 1 Nº 3	20 x 7 25 x 9 30 x 11 38 x 10 45 x 14	-	28	1.009,64	888,07
D645	UNF 1/4 - 5/16 - 3/8 - 7/16 - 1/2 - 5/8 3/4 - 7/8 - 1"	Nº 1 Nº 4	20 x 7 25 x 9 30 x 11 38 x 10 45 x 14 55 x 16	-	34	1.238,02	1.122,51



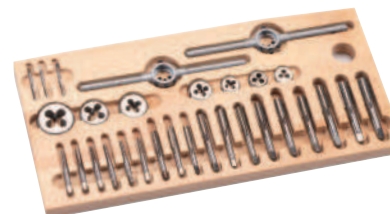

UNC
UNF

HSS

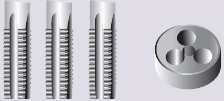

Ref. D670

CONTENIDO

					Nº Piezas	1ª Calidad €	2ª Calidad €
D670	UNC 1/4 - 5/16 - 3/8 - 7/16 - 1/2 - 5/8 - 3/4 UNF 1/4 - 5/16 - 3/8 - 7/16 - 1/2 - 5/8 - 3/4	Nº 1 Nº 3	20 x 7 25 x 9 30 x 11 38 x 14 45 x 18	-	35	1.866,31	1.641,59



Ref. JMB0









Ref. JMB2

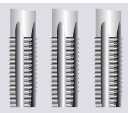

Ref. JMBT2

CONTENIDO

					HSS €		TiN* €
JMB2	M3 - M4 - M5 - M6 M8 - M10 - M12	-	-	-	173,42	JMBT2	344,33
JMB0	M3 - M4 - M5 - M6 M8 - M10 - M12	2.5 / 3.3 / 4.2 / 5.0 6.8 / 8.5 / 10.2 mm	-	-	197,82	JMBT0	386,41
JMB1	M3 - M4 - M5 - M6 M8 - M10 - M12	2.5 / 3.3 / 4.2 / 5.0 6.8 / 8.5 / 10.2 mm	Nº 1.1/2	-	212,90	JMBT1	331,12
JMB5	M3 - M4 - M5 - M6 M8 - M10 - M12	2.5 / 3.3 / 4.2 / 5.0 6.8 / 8.5 / 10.2 mm	Nº 1.1/2	TC1	226,13	JMBT5	346,95
JMBI2 (Izq)	 M3 - M4 - M5 - M6 M8 - M10 - M12	-	-	-	321,60	JMBIT2	598,17
JMBI0 (Izq)	 M3 - M4 - M5 - M6 M8 - M10 - M12	2.5 / 3.3 / 4.2 / 5.0 6.8 / 8.5 / 10.2 mm	-	-	372,56	JMBIT0	648,79
JMBI1 (Izq)	 M3 - M4 - M5 - M6 M8 - M10 - M12	2.5 / 3.3 / 4.2 / 5.0 6.8 / 8.5 / 10.2 mm	Nº 1.1/2	-	387,10	JMBIT1	662,24

MACHOS TERCEROS DE MANO HSS Y TiN EN ESTUCHES METÁLICOS









Ref. JMB3



Ref. JMB4

CONTENIDO

3º					HSS €		TiN* €
JMB3	M3 - M4 - M5 - M6 M8 - M10 - M12	-	-	-	79,61	JMBT3	99,69
JMB4	M3 - M4 - M5 - M6 M8 - M10 - M12	2.5 / 3.3 / 4.2 / 5.0 6.8 / 8.5 / 10.2 mm	-	-	99,08	JMBT4	131,71
JMB7	M3 - M4 - M5 - M6 M8 - M10 - M12	2.5 / 3.3 / 4.2 / 5.0 6.8 / 8.5 / 10.2 mm	Nº 1.1/2	-	113,38	JMBT7	182,69
JMB6	M3 - M4 - M5 - M6 M8 - M10 - M12	2.5 / 3.3 / 4.2 / 5.0 6.8 / 8.5 / 10.2 mm	Nº 1.1/2	TC1	122,77	JMBT6	194,71
JMBI3 (Izq)	 M3 - M4 - M5 - M6 M8 - M10 - M12	-	-	-	107,18	JMBIT3	199,38
JMBI4 (Izq)	 M3 - M4 - M5 - M6 M8 - M10 - M12	2.5 / 3.3 / 4.2 / 5.0 6.8 / 8.5 / 10.2 mm	-	-	143,63	JMBIT4	264,28



HSSCo
5%



Ref. JMBX0

CONTENIDO

INOX	MOX	HSSCo			€
JMBX0	M3 - M4 - M5 - M6 M8 - M10 - M12	2.5 / 3.3 / 4.2 / 5.0 6.8 / 8.5 / 10.2 mm	-	-	273,36
JMBX1	M3 - M4 - M5 - M6 M8 - M10 - M12	2.5 / 3.3 / 4.2 / 5.0 6.8 / 8.5 / 10.2 mm	Nº 1.1/2	-	287,70
JMBX2	M3 - M4 - M5 - M6 M8 - M10 - M12	-	-	-	258,49

CONTENIDO

1100 N/mm ²	MOMD	HSSCo			€
JMBMD0	M3 - M4 - M5 - M6 M8 - M10 - M12	2.5 / 3.3 / 4.2 / 5.0 6.8 / 8.5 / 10.2 mm	-	-	285,48
JMBMD1	M3 - M4 - M5 - M6 M8 - M10 - M12	2.5 / 3.3 / 4.2 / 5.0 6.8 / 8.5 / 10.2 mm	Nº 1.1/2	-	300,33
JMBMD2	M3 - M4 - M5 - M6 M8 - M10 - M12	-	-	-	272,13

ESTUCHES DE COJINETES EN CAJAS METÁLICAS HSS





Ref. C5B3

CONTENIDO



		HSS
		€
C5B3	M3 - M4 - M5 - M6 - M8 - M10 - M12	207,19
C5B3I (Izq)	M3 - M4 - M5 - M6 - M8 - M10 - M12	410,36



EXTRACTORES SUELTOS

Ø MACHO A EXTRAER		MACHOS DE MANO	MACHOS DE MÁQUINA	€/ Ud.
BSW UNC	M			EXTRACTOR COMPLETO
--	M3		W10043	39,51
1/8	M3,2		W10053	39,51
--	M3,5		W10063	39,51
5/32	M4		W10083	39,51
3/16	M5		W10103	39,51
--	M5,5	W10124	W10123	39,51
1/4	M6	W10254	W10253	40,67
5/16	M8	W10314	W10313	42,62
--	M9	W10374	W10373	42,21
3/8	M10	W10404	W10373	42,21
7/16	M11	W10434	W10433	44,56
1/2	M12	W10504	W10503	47,65
9/16	M14	W10564	W10563	65,86
5/8	M16	W10624	W10623	71,67
--	M18	W10684	W10753	88,81
3/4	M20	W10754	W10753	88,81
7/8	M22	W10874	W10873	97,17
1"	M25	W11004	W11003	108,36

VARILLA REPUESTO

MACHOS DE MANO	MACHOS DE MÁQUINA	€/ Ud.
		VARILLA EXTRA
	W12043	2,10
	W12053	2,10
	W12063	2,10
	W12083	2,10
	W12103	3,14
	W12123	3,14
	W12253	3,82
W12314	W12313	4,32
W12374		4,32
W12404	W12373	4,45
W12434	W12433	4,53
W12504	W12503	5,69
W12564	W12563	6,35
W12624	W12623	8,12
W12684		8,12
W12754	W12753	8,59
W12874	W12873	11,14
W13004	W13003	18,53

3 SIMPLES PASOS PARA EXTRAER MACHOS DE ROSCAR ROTOS DE CANALES RECTOS

Sacar toda la viruta del macho roto. Introducir las varillas del extractor en los canales del macho roto con firmeza hasta el fondo.



Empujar el soporte hacia abajo, hasta tocar el macho roto. Deslice el casquillo hacia abajo, hasta tocar la zona de trabajo.

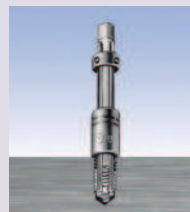

Aplicar al cuadradillo del extractor un gira-machos. Gire a izquierdas unas cuantas veces hasta soltarlo y entonces saque el macho roto.

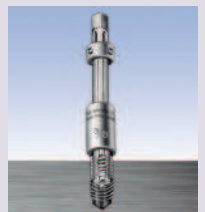

JUEGOS DE EXTRACTORES PARA MACHOS ROTOS (CANALES RECTOS)



Nº CANALES	MEDIDAS INCLUIDAS PARA MACHOS DE MÁQUINA Y DE MANO: 3 y 4 CANALES	
W180013	3	M5- M6- M8- M10- M11- M12
W180014	4	3/16 - 1/4 - 5/16 - 3/8 - 7/16 - 1/12
W180023	3	M6- M8 -M10- M11- M12- M16
W180024	4	1/4 - 5/16 - 3/8 - 7/16 - 1/12 - 5/8
W180153	3	M3- M3,2- M3,5- M4-M5- M5,50- M6- M8
W180154	4	M9- M10- M12- M16- M18- M22- M25
		273,90
		308,16
		862,01

M
MF

DIN 13 **HSSCo**
5%

TOL
6H

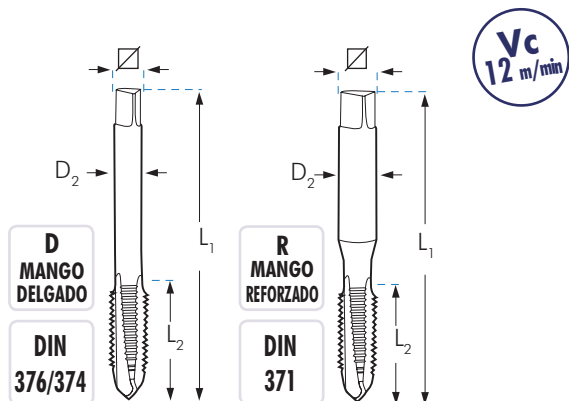

		L1 x L2 x D2 x \square mm	M1D	M2D	M3D	M4D	M1R	M2R	M3R	M4R
			FORMA C	FORMA B	15°	35°	FORMA C	FORMA B	15°	35°
			€	€	€	€	€	€	€	€
M 1x0,25	0,75	R 40 x 6 x 2,5 x 2,1					36,14			
M 1,1x0,25	0,85	R 40 x 6 x 2,5 x 2,1					35,16			
M 1,2x0,25	0,95	R 40 x 6 x 2,5 x 2,1					32,12			
M 1,4x0,30	1,10	R 40 x 7 x 2,5 x 2,1					32,12			
M 1,6x0,35	1,25	R 40 x 8 x 2,5 x 2,1					31,54			
M 1,7x0,35	1,35	R 40 x 8 x 2,5 x 2,1					30,38			
M 1,8x0,35	1,45	R 40 x 8 x 2,5 x 2,1					29,63			
M 2x0,40	1,60	R 40 x 9 x 2,8 x 2,1					13,77	15,54	18,00	18,34
M 2,2x0,45	1,75	R 40 x 9 x 2,8 x 2,1					15,41			
M 2,3x0,40	1,90	R 40 x 9 x 2,8 x 2,1					14,20			
M 2,5x0,45	2,05	R 50 x 9 x 2,8 x 2,1					13,77	15,54	25,31	18,34
M 2,6x0,45	2,10	R 50 x 9 x 2,8 x 2,1					14,30	15,81		30,49
M 3x0,50	2,50	R 56 x 11 x 3,5 x 2,7 D 56 x 11 x 2,2 x 1,8	9,81	10,63	14,00	12,74	9,63*	9,96	14,36	13,06
M 3x0,60	2,40	R 56 x 11 x 3,5 x 2,7					16,80	18,67		24,66
M 3,5x0,60	2,90	R 56 x 12 x 4,0 x 3,0 D 56 x 12 x 2,5 x 2,1					13,25	14,05	18,15	17,03
M 3,5x0,75	2,75	R 56 x 12 x 4,0 x 3,0					18,16			
M 4x0,50	3,50	R 63 x 13 x 4,5 x 3,4 D 63 x 13 x 2,8 x 2,1	20,53	22,78		24,77	19,77	22,41		25,95
M 4x0,70	3,30	R 63 x 13 x 4,5 x 3,4 D 63 x 13 x 2,8 x 2,1	9,98	10,74	15,27	12,63	10,37*	10,43	14,04	13,07
M 4x0,75	3,25	R 63 x 13 x 4,5 x 3,4					15,03	16,36		
M 4x0,80	3,20	R 63 x 13 x 4,5 x 3,4					79,82			
M 4,5x0,50	4,00	R 70 x 14 x 6,0 x 4,9						26,08		
M 4,5x0,75	3,75	R 70 x 14 x 6,0 x 4,9					17,90	20,09		
M 5x0,50	4,50	R 70 x 14 x 6,0 x 4,9 D 70 x 11 x 3,5 x 2,7	21,14	23,41		25,05	20,36	23,03		27,68
M 5x0,75	4,50	R 74 x 14 x 6,0 x 4,9 D 70 x 16 x 3,5 x 2,7					18,26	21,83		27,50
M 5x0,80	4,20	R 70 x 16 x 6,0 x 4,9 D 70 x 16 x 3,5 x 2,7	9,98	10,69	14,64	12,12	9,90*	10,45	13,46	12,53
M 5x0,90	4,10	R 70 x 15 x 6,0 x 4,9 D 70 x 16 x 3,5 x 2,7					15,89	20,84		
M 5x1,00	4,00	R 72 x 17 x 6,0 x 4,9					42,55			
M 5,5x0,90	4,60	R 80 x 17 x 6,0 x 4,9					42,55			
M 6x0,50	5,50	R 80 x 17 x 6,0 x 4,9 D 80 x 13 x 4,5 x 3,4	25,04	30,93		40,14	26,66			
M 6x0,75	5,25	R 80 x 13 x 6,0 x 4,9 D 80 x 13 x 4,5 x 3,4	16,49	19,25		23,11	17,27	20,50		24,62
M 6x1,00	5,00	R 80 x 17 x 6,0 x 4,9 D 80 x 17 x 4,5 x 3,4	11,38	11,72	14,77	13,29	11,27*	11,46	14,77	13,75

* Disponibles también con rosca izquierda con 100% de recargo sobre los precios tarifados en rosca derecha

M
MF



DIN 13
60°

HSSCo
5%

TOL
6H

D
MANGO
DELGADO

DIN
376/374



Vc
12 m/min

R
MANGO
REFORZADO

DIN
371

			L1 x L2 x D2 x ∇ mm	M1D	M2D	M3D	M4D	M1R	M2R	M3R	M4R
				FORMA C €	FORMA B €	15° €	35° €	FORMA C €	FORMA B €	15° €	35° €
M 6x1,25	4,75	R	80 x 17 x 6,0 x 4,9					41,83			
M 7x0,75	6,25	D	80 x 13 x 5,5 x 4,3	22,01	23,74		30,14				
M 7x1,00	6,00	R	80 x 17 x 7,0 x 5,5	14,24	16,45	18,43	18,24	13,97*	16,30	18,43	18,24
		D	80 x 17 x 5,5 x 4,3								
M 8x0,50	7,50	D	80 x 13 x 6 x 4,9	27,77							
M 8x0,75	7,25	D	80 x 13 x 6 x 4,9	20,13	24,67		32,61				
M 8x1,00	7,00	D	90 x 20 x 6 x 4,9	16,45	18,89	23,45	21,52				
M 8x1,25	6,80	R	90 x 20 x 8 x 6,2	12,78	13,09	17,76	15,52	12,73*	12,85	17,50	15,55
		D	90 x 20 x 6 x 4,9								
M 8x1,50	6,50	D	90 x 20 x 6 x 4,9	84,36							
M 9x1,00	8,00	D	90 x 20 x 7 x 5,5	24,89	27,57		29,30				
M 9x1,25	7,80	R	90 x 20 x 9 x 7,0	20,73	21,78	26,38	25,78	20,91	21,58	27,08	27,27
		D	90 x 20 x 7 x 5,5								
M 10x0,50	9,50	D	90 x 20 x 7 x 5,5	83,58							
M 10x0,75	9,25	D	90 x 16 x 7 x 5,5	31,90	33,13		40,34				
M 10x1,00	9,00	D	90 x 16 x 7 x 5,5	18,22	20,99	27,69	25,45				
M 10x1,25	8,80	D	100 x 22 x 7 x 5,5	20,86	25,10	30,18	27,74				
M 10x1,50	8,50	R	100 x 22 x 10 x 8,0	14,30	16,14	20,92	18,42	14,43*	15,83	19,54	18,42
		D	100 x 22 x 7 x 5,5								
M 11x0,75	10,25	D	90 x 20 x 8 x 6,2								
M 11x1,00	10,00	D	90 x 20 x 8 x 6,2	32,66	34,96	88,37	80,42				
M 11x1,25	9,75	D	100 x 22 x 8 x 6,2	32,38	35,98	88,37	71,78				
M 11x1,50	9,50	D	100 x 22 x 8 x 6,2	26,26	29,67	64,44	58,61				
M 12x0,75	11,25	D	100 x 22 x 9 x 7,0	49,59							
M 12x1,00	11,00	D	100 x 22 x 9 x 7,0	24,78	28,36	34,17	32,60				
M 12x1,25	10,75	D	100 x 22 x 9 x 7,0	25,08	27,86	32,71	31,22				
M 12x1,50	10,50	D	100 x 22 x 9 x 7,0	22,42*	24,85	31,46	30,02				
M 12x1,75	10,20	D	100 x 24 x 9 x 7,0	17,22*	19,96	27,52	23,72				
M 13x0,75	12,25	D	100 x 22 x 11 x 9,0	86,55							
M 13x1,00	12,00	D	100 x 22 x 11 x 9,0	45,83	51,90						
M 13x1,25	11,75	D	100 x 22 x 11 x 9,0	45,83	51,90						
M 13x1,50	11,50	D	100 x 22 x 11 x 9,0	45,83	51,90						
M 13x1,75	11,25	D	100 x 22 x 11 x 9,0	45,51	51,90						
M 14x0,75	13,25	D	100 x 22 x 11 x 9,0	86,55							
M 14x1,00	13,00	D	100 x 22 x 11 x 9,0	39,89	43,88	52,68	52,23				
M 14x1,25	12,80	D	100 x 22 x 11 x 9,0	33,95	37,05	48,31	44,40				
M 14x1,50	12,50	D	100 x 22 x 11 x 9,0	26,70*	29,42	38,10	35,02				
M 14x2,00	12,00	D	110 x 26 x 11 x 9,0	26,52*	29,47	34,16	34,15				
M 15x1,00	14,00	D	100 x 22 x 12 x 9,0	50,73	55,65		70,87				
M 15x1,25	13,75	D	100 x 22 x 12 x 9,0	56,31	60,97						
M 15x1,50	13,50	D	100 x 22 x 12 x 9,0	45,00	49,53	131,13	106,37				
M 15x2,00	13,00	D	110 x 27 x 12 x 9,0	55,09	60,63						
M 16x1,00	15,00	D	100 x 22 x 12 x 9,0	47,81	52,57	73,74	71,60				
M 16x1,25	14,75	D	100 x 22 x 12 x 9,0	53,01	58,29	82,00	79,42				
M 16x1,50	14,50	D	100 x 22 x 12 x 9,0	31,57*	36,79	47,48	43,64				
M 16x2,00	14,00	D	110 x 27 x 12 x 9,0	31,22*	34,47	41,27	41,26				
M 17x1,00	16,00	D	100 x 22 x 12 x 9,0	98,58							
M 17x1,25	15,75	D	100 x 22 x 12 x 9,0	98,58							
M 17x1,50	15,50	D	100 x 22 x 12 x 9,0	98,58							
M 18x1,00	17,00	D	110 x 25 x 14 x 11,0	53,54	58,84		87,62				
M 18x1,25	16,75	D	110 x 25 x 14 x 11,0	68,78							
M 18x1,50	16,50	D	110 x 25 x 14 x 11,0	41,80*	46,00	58,34	54,77				
M 18x2,00	16,00	D	125 x 30 x 14 x 11,0	58,99	65,98	115,44	103,04				

* Disponibles también con rosca izquierda con 100% de recargo sobre los precios tarifados en rosca derecha

M
MF

DIN 13 60°

HSSCo
5%

TOL
6H

D
MANGO
DELGADO

DIN
376/374

Vc
12
m/min

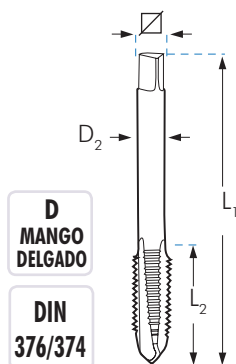

	L1 x L2 x D2 x \square mm	FORMA			
		C	B	15°	35°
		€	€	€	€
M 18x2,50	15,50 D 125 x 30 x 14 x 11,0	44,91*	49,11	55,56	53,50
M 19x1,00	18,00 D 110 x 22 x 14 x 11,0	129,53			
M 19x1,25	17,75 D 110 x 25 x 14 x 11,0	133,20			
M 19x1,50	17,50 D 110 x 25 x 14 x 11,0	127,13			
M 19x2,00	17,00 D 110 x 25 x 14 x 11,0				
M 20x1,00	19,00 D 125 x 25 x 16 x 12,0	70,69	78,49		93,58
M 20x1,25	18,75 D 125 x 25 x 16 x 12,0	129,53			
M 20x1,50	18,50 D 125 x 25 x 16 x 12,0	47,34*	52,03	65,57	62,57
M 20x2,00	18,00 D 140 x 32 x 16 x 12,0	62,04	68,22		83,48
M 20x2,50	17,50 D 140 x 32 x 16 x 12,0	47,81*	53,01	59,29	59,30
M 21x1,00	20,00 D 125 x 25 x 16 x 12,0	188,07			
M 21x1,25	19,75 D 125 x 25 x 16 x 12,0	188,07			
M 21x1,50	19,50 D 125 x 25 x 16 x 12,0	179,60			
M 22x1,00	21,00 D 125 x 25 x 18 x 14,5	79,23	87,15		120,59
M 22x1,25	20,75 D 125 x 25 x 18 x 14,5	129,53			
M 22x1,50	20,50 D 125 x 25 x 18 x 14,5	56,98	62,69	71,93	65,30
M 22x2,00	20,00 D 140 x 32 x 18 x 14,5	79,23	87,15		120,59
M 22x2,50	19,50 D 140 x 32 x 18 x 14,5	57,86*	63,63	72,88	69,59
M 23x1,00	22,00 D 125 x 25 x 18 x 14,5	182,84			
M 23x1,50	21,50 D 125 x 25 x 18 x 14,5	182,84			
M 24x1,00	23,00 D 140 x 25 x 18 x 14,5	86,34	108,55		127,42
M 24x1,25	22,75 D 140 x 25 x 18 x 14,5	188,07			
M 24x1,50	22,50 D 140 x 28 x 18 x 14,5	70,09	77,05	96,14	88,36
M 24x2,00	22,00 D 140 x 28 x 18 x 14,5	89,42*	97,42		115,30
M 24x3,00	21,00 D 160 x 34 x 18 x 14,5	69,26*	75,80	87,83	84,59
M 25x1,00	24,00 D 140 x 28 x 18 x 14,5	173,47			
M 25x1,25	23,75 D 140 x 28 x 18 x 14,5	274,11			
M 25x1,50	23,50 D 140 x 28 x 18 x 14,5	109,04	119,61		
M 25x2,00	23,00 D 140 x 28 x 18 x 14,5	243,27	267,61		
M 26x1,00	25,00 D 140 x 28 x 18 x 14,5	134,68			
M 26x1,50	24,50 D 140 x 28 x 18 x 14,5	94,51	99,07	180,10	158,37
M 26x2,00	24,00 D 140 x 28 x 18 x 14,5	243,27	267,61		111,04
M 27x1,00	26,00 D 140 x 28 x 20 x 16,0	120,62	155,75		
M 27x1,50	25,50 D 140 x 28 x 20 x 16,0	103,19	113,30	261,74	236,01
M 27x2,00	25,00 D 140 x 28 x 20 x 16,0	127,64*	135,06		

* Disponibles también con rosca izquierda con 100% de recargo sobre los precios tarifados en rosca derecha

M
MF

DIN 13 60°

HSSCo
5%

TOL
6H

D
MANGO
DELGADO

DIN
376/374

Vc
12 m/min

			L1 x L2 x D2 x	M1D	M2D	M3D	M4D
				FORMA C	FORMA B		
				€	€	€	€
M 27x3,00	24,00	D	160 x 36 x 20 x 16	86,46*	94,80	108,08	104,08
M 28x1,00	27,00	D	140 x 28 x 20 x 16	243,27			
M 28x1,50	26,50	D	140 x 28 x 20 x 16	103,19	113,30	136,31	123,06
M 28x2,00	26,00	D	140 x 28 x 20 x 16	130,47	147,36	160,64	157,96
M 30x1,00	29,00	D	150 x 28 x 22 x 18	132,00	158,17		184,41
M 30x1,50	28,50	D	150 x 28 x 22 x 18	107,56	118,36	147,82	135,84
M 30x2,00	28,00	D	150 x 28 x 22 x 18	133,14*	146,44		202,64
M 30x3,00	27,00	D	150 x 28 x 22 x 18				
M 30x3,50	26,50	D	180 x 40 x 22 x 18	110,79*	121,81	138,52	133,38
M 32x1,00	31,00	D	150 x 28 x 22 x 18	324,38	344,43		
M 32x1,50	30,50	D	150 x 28 x 22 x 18	136,10	149,43	182,11	
M 32x2,00	30,00	D	150 x 28 x 22 x 18	173,32	265,39		
M 33x1,00	32,00	D	160 x 30 x 25 x 20	298,75			
M 33x1,50	31,50	D	160 x 30 x 25 x 20	153,34	162,63		196,17
M 33x2,00	31,00	D	160 x 30 x 25 x 20	251,32	276,37		324,87
M 33x3,50	29,50	D	180 x 40 x 25 x 20	133,14*	153,20		176,10
M 34x1,50	32,50	D	170 x 30 x 28 x 22	176,99	187,49		
M 34x2,00	32,00	D	160 x 30 x 28 x 22	372,21			
M 35x1,50	33,50	D	170 x 30 x 28 x 22	180,11	198,10		224,52
M 35x2,00	33,00	D	170 x 30 x 28 x 22	343,47	378,12		
M 36x1,50	34,50	D	170 x 30 x 28 x 22	170,44	194,42		243,90
M 36x2,00	34,00	D	170 x 30 x 28 x 22	230,20	253,22		
M 36x3,00	33,00	D	200 x 50 x 28 x 22	264,11	290,48		353,00
M 36x4,00	32,00	D	200 x 50 x 28 x 22	176,36*	187,20	225,35	215,62
M 38x1,50	36,50	D	170 x 30 x 28 x 22	181,69	204,72		
M 38x2,00	36,00	D	170 x 32 x 28 x 22	386,19	424,83		
M 39x1,50	37,50	D	170 x 32 x 32 x 24	285,51			
M 39x2,00	37,00	D	170 x 32 x 32 x 24	285,51			
M 39x3,00	36,00	D	200 x 47 x 32 x 24	372,86			
M 39x4,00	35,00	D	200 x 50 x 32 x 24	217,27	239,00		
M 40x1,50	38,50	D	170 x 30 x 32 x 24	237,57	261,49		
M 40x2,00	38,00	D	170 x 30 x 32 x 24	286,26			
M 40x3,00	37,00	D	200 x 47 x 32 x 24	280,67	334,86		
M 42x1,50	40,50	D	170 x 30 x 32 x 24	250,13	268,10		
M 42x2,00	40,00	D	170 x 30 x 32 x 24	327,48			
M 42x3,00	39,00	D	200 x 45 x 32 x 24	327,48	415,00		
M 42x4,50	37,50	D	200 x 56 x 32 x 24	279,38	307,24		
M 45x1,50	43,50	D	180 x 32 x 36 x 29	298,75	328,59		
M 45x2,00	43,00	D	180 x 32 x 36 x 29	379,19			
M 45x3,00	42,00	D	200 x 47 x 36 x 29	379,19			
M 45x4,50	40,50	D	220 x 58 x 36 x 29	305,18	335,69		
M 48x1,50	46,50	D	190 x 32 x 36 x 29	305,18			
M 48x2,00	46,00	D	190 x 32 x 36 x 29	475,82			
M 48x3,00	45,00	D	220 x 52 x 36 x 29	459,51			
M 48x5,00	43,00	D	250 x 65 x 36 x 29	375,29	412,79		
M 50x1,50	48,50	D	190 x 32 x 36 x 29	356,91			
M 52x1,50	50,50	D	190 x 32 x 40 x 32	361,34			
M 52x2,00	50,00	D	190 x 32 x 40 x 32	571,82			
M 52x3,00	49,00	D	225 x 50 x 40 x 32	587,67			
M 52x5,00	47,00	D	250 x 65 x 40 x 32	384,34	475,55		

* Disponibles también con rosca izquierda con 100% de recargo sobre los precios tarifados en rosca derecha

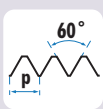

HSSCo
5%

TOL
2B

Vc
12 m/min

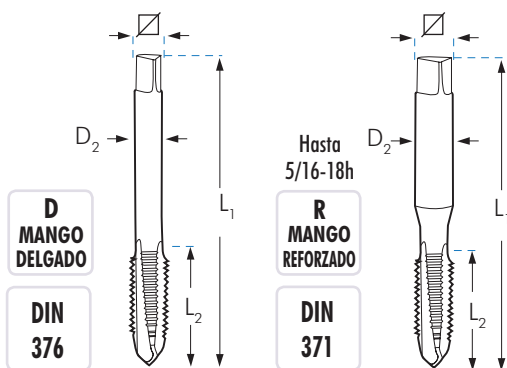

UNC nº	D1 mm	D2 mm	R	L1 x L2 x D2 x mm	M1R	M2R	M3R	M4R
					FORMA C	FORMA B	15°	35°
					€	€	€	€
UNC nº 1-64h	1,85	1,50	R	40 x 8 x 2,5 x 2,1				
UNC nº 2-56h	2,18	1,80	R	45 x 9 x 2,8 x 2,1				
UNC nº 3-48h	2,51	2,10	R	50 x 9 x 2,8 x 2,1				
UNC nº 4-40h	2,84	2,25	R	56 x 11 x 3,5 x 2,7	21,99	26,39		30,11
UNC nº 5-40h	3,17	2,60	R	56 x 11 x 3,5 x 2,7	21,99	26,39		30,11
UNC nº 6-32h	3,50	2,75	R	56 x 12 x 4,0 x 3,0	20,93	25,15		28,67
UNC nº 8-32h	4,17	3,50	R	63 x 13 x 4,5 x 3,4	20,93	25,15		28,67
UNC nº 10-24h	4,83	3,90	R	70 x 15 x 6,0 x 4,9	21,99	26,39		30,11
UNC nº 12-24h	5,49	4,50	R	80 x 16 x 6,0 x 4,9	23,07	26,39		28,91
UNC 1/4-20h	6,35	5,10	R	80 x 17 x 7,0 x 5,5	20,55	22,42		25,86
UNC 5/16-18h	7,94	6,60	R	90 x 20 x 8,0 x 6,2	23,26	25,65		29,20

MANGO DELGADO				M1D	M2D	M3D	M4D	
UNC	D	D	D					
UNC 3/8-16h	9,52	8,00	D	100 x 22 x 7,0 x 5,5	26,53	29,09		32,69
UNC 7/16-14h	11,11	9,40	D	100 x 22 x 8,0 x 6,2	36,50	36,63		45,81
UNC 1/2-13h	12,70	10,75	D	110 x 24 x 9,0 x 7,0	39,61	43,89		50,10
UNC 9/16-12h	14,28	12,20	D	110 x 26 x 11,0 x 9,0	54,45	59,79		68,02
UNC 5/8-11h	15,87	13,50	D	110 x 27 x 12,0 x 9,0	52,90	58,23		66,15
UNC 3/4-10h	19,05	16,50	D	125 x 30 x 14,0 x 11,0	70,04	77,00		87,61
UNC 7/8-9h	22,22	19,50	D	140 x 32 x 18,0 x 14,5	92,17	101,25		137,09
UNC 1"-8h	25,40	22,25	D	160 x 36 x 18,0 x 14,5	121,78	133,03		171,97
UNC 1.1/8-7h	28,57	25,00	D	180 x 40 x 22,0 x 18,0	159,07			200,97
UNC 1.1/4-7h	31,75	28,00	D	180 x 40 x 22,0 x 18,0	195,00			257,09
UNC 1.3/8-6h	34,92	30,75	D	200 x 50 x 28,0 x 22,0	290,86			
UNC 1.1/2-6h	38,10	34,00	D	200 x 50 x 32,0 x 24,0	330,31			
UNC 1.3/4-5h	44,45	39,00	D	220 x 58 x 36,0 x 29,0				
UNC 2"-4,5h	50,80	45,00	D	250 x 65 x 40,0 x 32,0				

UNF

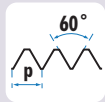

HSSCo
5%

TOL
2B

Vc
12 m/min

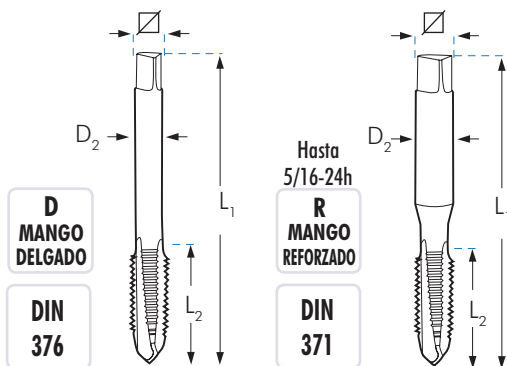

UNF nº	D1 mm	D2 mm	L1 x L2 x D2 x mm	M1R	M2R	M3R	M4R
				FORMA C	FORMA B	15°	35°
				€	€	€	€
UNF nº 1-72h	1,85	1,50	R 40 x 8 x 2,5 x 2,1				
UNF nº 2-64h	2,18	1,85	R 45 x 9 x 2,8 x 2,1				
UNF nº 3-56h	2,51	2,15	R 50 x 9 x 2,8 x 2,1				
UNF nº 4-48h	2,84	2,35	R 56 x 11 x 3,5 x 2,7	23,23	25,29		31,74
UNF nº 5-44h	3,17	2,70	R 56 x 11 x 3,5 x 2,7	23,23	25,29		31,74
UNF nº 6-40h	3,50	2,95	R 56 x 12 x 4,0 x 3,0	22,22	26,61		31,50
UNF nº 8-36h	4,17	3,50	R 63 x 13 x 4,5 x 3,4	22,22	26,61		31,50
UNF nº 10-32h	4,83	4,10	R 70 x 15 x 6,0 x 4,9	22,22	26,61		31,50
UNF nº 12-28h	5,49	4,60	R 80 x 16 x 6,0 x 4,9	23,23	27,84		31,74
UNF 1/4-28h	6,35	5,50	R 80 x 17 x 7,0 x 5,5	18,76	20,10		23,45
UNF 5/16-24h	7,94	6,90	R 90 x 20 x 8,0 x 6,2	20,98	23,13		27,04

UNF	MANGO DELGADO	D1 mm	D2 mm	D	L1 x L2 x D2 x mm	M1D	M2D	M3D	M4D
UNF 3/8-24h	9,52	8,50	D	90 x 16 x 7,0 x 5,5	22,97	26,57		32,35	
UNF 7/16-20h	11,11	9,90	D	100 x 22 x 8,0 x 6,2	28,34	32,84		41,45	
UNF 1/2-20h	12,70	11,50	D	100 x 22 x 9,0 x 7,0	30,18	34,93		44,11	
UNF 9/16-18h	14,29	12,90	D	100 x 22 x 11,0 x 9,0	37,08	42,93		54,61	
UNF 5/8-18h	15,87	14,50	D	100 x 22 x 12,0 x 9,0	41,74	48,28		61,02	
UNF 3/4-16h	19,05	17,50	D	110 x 25 x 14,0 x 11,0	53,40	61,84		78,06	
UNF 7/8-14h	22,22	20,40	D	125 x 25 x 18,0 x 14,5	67,16	84,01		119,39	
UNF 1"-12h	25,40	23,25	D	140 x 28 x 18,0 x 14,5	101,08	110,06		146,98	
UNS 1"-14h	25,40	23,60	D	140 x 28 x 18,0 x 14,5	106,13	113,23		146,98	
UNF 1.1/8-12h	28,57	26,50	D	150 x 28 x 22,0 x 18,0	154,02				
UNF 1.1/4-12h	31,75	29,50	D	150 x 28 x 22,0 x 18,0	194,63				
UNF 1.3/8-12h	34,92	33,00	D	170 x 30 x 28,0 x 22,0					
UNF 1.1/2-12h	38,10	36,00	D	170 x 30 x 32,0 x 24,0	326,66				
UNF 2"-12h	50,80	36,00	D	200 x 70 x 35,5 x 28,0					

BSP
(GAS)

55°

HSSCo
5%

TOL
ISO 228

INOX

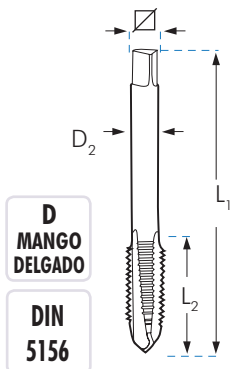

Forma	D1 mm	D	L1 x L2 x D2 x ∇ mm	M1D	M2D	M3D	M4D	M2DX	M4DX
				FORMA C €	FORMA B €	15° €	35° €	FORMA B €	35° €
G 1/8-28h.	9,728	8,80	D 90 x 16 x 7 x 5,5	28,09*	32,09	34,38	34,06	49,98	49,47
G 1/4-19h.	13,157	11,80	D 100 x 22 x 11 x 9,0	38,96*	42,89	49,37	48,91	67,34	72,07
G 3/8-19h.	16,662	15,25	D 100 x 22 x 12 x 9,0	46,64*	51,32	58,97	58,41	79,89	84,71
G 1/2-14h.	20,955	19,00	D 125 x 25 x 16 x 12,0	58,95*	64,86	74,38	73,67	98,92	106,91
G 5/8-14h.	22,911	21,00	D 125 x 25 x 18 x 14,5	73,46*	80,57	92,60	91,74		
G 3/4-14h.	26,441	24,50	D 140 x 28 x 20 x 16,0	92,27	101,54	116,42	115,32	142,91	164,89
G 7/8-14h.	30,201	28,25	D 150 x 28 x 22 x 18,0	124,02	136,46	156,57	155,11		
G 1"-11h.	33,249	30,75	D 160 x 30 x 25 x 20,0	143,21	157,50	178,75	177,10		
G 1.1/8-11h.	37,897	35,50	D 170 x 30 x 28 x 22,0	228,68	260,89		286,54		
G 1.1/4-11h.	41,910	39,50	D 170 x 30 x 32 x 24,0	268,33	295,28		326,89		
G 1.3/8-11h.	44,323	42,00	D 180 x 32 x 36 x 29,0	335,57			454,05		
G 1.1/2-11h.	47,803	45,25	D 190 x 32 x 36 x 29,0	427,87	596,46		590,97		
G 1.3/4-11h.	53,746	51,25	D 190 x 32 x 40 x 32,0	508,57	615,36				
G 2"-11h.	59,614	57,00	D 220 x 36 x 45 x 35,0	648,63	675,25				

* Disponibles también con rosca izquierda con 100% de recargo sobre los precios tarifados en rosca derecha

BSF

55°

HSSCo
5%

TOL
ISO 228

Vc
12 m/min

D
MANGO
DELGADO

DIN
5156

Forma	D1 mm	D	L1 x L2 x D2 x ∇ mm	M1D	M2D	M3D	M4D
				FORMA C €	FORMA B €	15° €	35° €
BSF 3/16-32h.	4,762	4,00	D 70 x 16 x 3,5 x 2,7	67,21			
BSF 1/4-26h.	6,350	5,20	D 80 x 17 x 4,5 x 3,4	29,41			
BSF 5/16-22h.	7,938	6,60	D 90 x 20 x 6,0 x 4,9	34,92			
BSF 3/8-20h.	9,525	8,10	D 100 x 22 x 7,0 x 5,5	36,72			
BSF 7/16-18h.	11,113	9,50	D 100 x 22 x 8,0 x 6,2	49,48			
BSF 1/2-16h.	12,700	11,00	D 110 x 24 x 9,0 x 7,0	56,00			
BSF 9/16-16h.	14,287	12,50	D 110 x 25 x 11,0 x 9,0	59,26			
BSF 5/8-14h.	15,876	14,00	D 110 x 27 x 12,0 x 9,0	78,99			
BSF 3/4-12h.	19,051	16,50	D 125 x 30 x 14,0 x 11,0	93,50			
BSF 7/8-11h.	22,226	19,50	D 140 x 32 x 18,0 x 14,5	129,96			
BSF 1"-10h.	25,400	22,50	D 160 x 36 x 18,0 x 14,5	151,06			

BSW

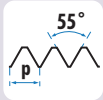

HSSCo
5%

TOL
Clase 2

Vc
12 m/min

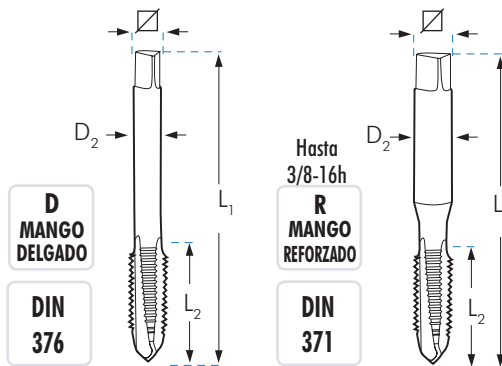

Icon	D1 mm	D	L1 x L2 x D2 x ∇ mm	M1R	M2R	M3R	M4R
				FORMA C	FORMA B	15°	35°
				€	€	€	€
W 1/16-60h.	1,59	1,15	R 40 x 8 x 2,5 x 2,1				
W 3/32-48h.	2,38	1,80	R 50 x 9 x 2,8 x 2,1	19,52	21,79		
W 1/8-40h.	3,17	2,55	R 56 x 11 x 3,5 x 2,7	16,29*	18,00	22,23	20,44
W 5/32-32h.	3,97	3,10	R 63 x 13 x 4,5 x 3,4	16,29	18,00	22,23	20,44
W 3/16-24h.	4,76	3,60	R 70 x 15 x 6,0 x 4,9	18,07	18,00	22,23	20,44
W 7/32-24h.	5,56	4,40	R 80 x 16 x 6,0 x 4,9	24,73	27,34		
W 1/4-20h.	6,35	5,10	R 80 x 17 x 7,0 x 5,5	17,40	20,44	25,23	24,99
W 5/16-18h.	7,94	6,50	R 90 x 20 x 8,0 x 6,2	20,40	25,79	29,44	28,11
W 3/8-16h.	9,52	7,90	R 100 x 22 x 10,0 x 8,0	21,83	28,50	32,72	31,23

MANGO DELGADO				M1D	M2D	M3D	M4D
W 7/16-14h.	11,11	9,25	D 100 x 22 x 8,0 x 6,2	31,75	31,38	41,25	39,72
W 1/2-12h.	12,70	10,50	D 110 x 24 x 9,0 x 7,0	30,45	32,73	39,53	38,06
W 9/16-12h.	14,29	12,00	D 110 x 26 x 11,0 x 9,0	43,65	45,33	56,68	54,58
W 5/8-11h.	15,87	13,40	D 110 x 27 x 12,0 x 9,0	41,33	42,83	53,60	51,61
W 11/16-11h.	17,46	15,25	D 110 x 27 x 12,0 x 9,0				
W 3/4-10h.	19,05	16,50	D 125 x 30 x 14,0 x 11,0	55,30	57,40	71,81	69,15
W 7/8-9h.	22,22	19,25	D 140 x 32 x 18,0 x 14,5	74,92	77,69	97,20	93,61
W 1"-8h.	25,40	21,75	D 160 x 36 x 18,0 x 14,5	94,15	97,64	121,98	117,46
W 1.1/8-7h.	28,57	24,75	D 180 x 40 x 22,0 x 18,0	122,09	145,50	174,96	
W 1.1/4-7h.	31,75	27,75	D 180 x 40 x 22,0 x 18,0	177,37	211,41		
W 1.3/8-6h.	34,92	30,50	D 200 x 50 x 28,0 x 22,0	291,53	347,17		
W 1.1/2-6h.	38,10	33,50	D 200 x 50 x 32,0 x 24,0	316,44	377,18		
W 1.5/8-5h.	41,27	46,50	D 220 x 65 x 32,0 x 24,0	441,68	526,48		
W 1.3/4-5h.	44,45	39,00	D 220 x 58 x 36,0 x 29,0	494,80	567,98		
W 1.7/8-4,5h.	47,62	42,00	D 250 x 75 x 36,0 x 29,0	548,57	629,66		
W 2"-4,5h.	50,80	44,50	D 250 x 65 x 40,0 x 32,0	708,17			
W 2.1/4-4h.	57,15	50,00					
W 2.1/2-4h.	63,50	56,50					
W 2.3/4-3,5h.	69,85	62,00					
W 3"-3,5h.	76,20	68,00					

* Disponibles también con rosca izquierda con 100% de recargo sobre los precios tarifados en rosca derecha

UNJC **HSSCo 5%** **TOL 3B**

UNJF **HSSCo 5%** **TOL 3B**

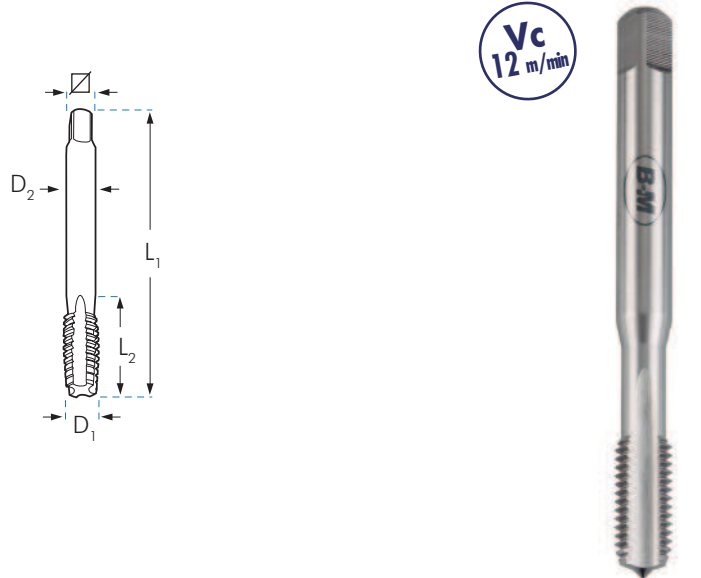
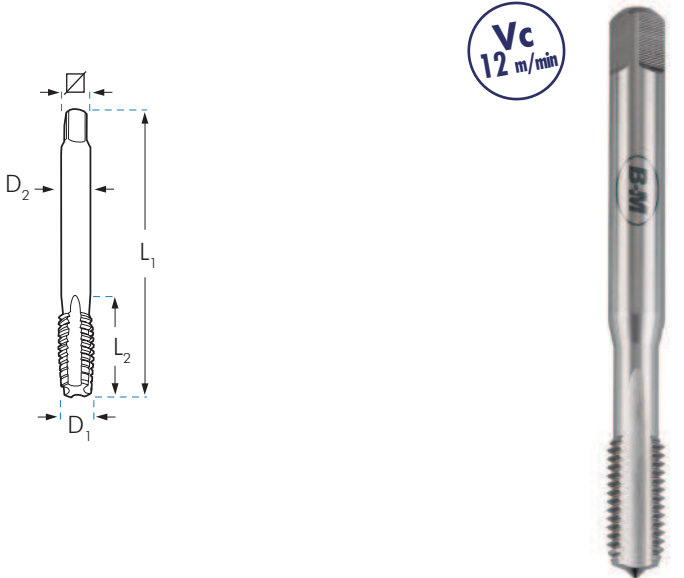

		D1 mm		L1 x L2 x D2 x ∇ mm	MTR
					FORMA C
					€
UNJC nº 4-40h	2,84	2,25	R	56 x 11 x 3,5 x 2,7	33,71
UNJC nº 5-40h	3,17	2,60	R	56 x 11 x 3,5 x 2,7	33,71
UNJC nº 6-32h	3,50	2,75	R	56 x 12 x 4,0 x 3,0	32,07
UNJC nº 8-32h	4,17	3,50	R	63 x 13 x 4,5 x 3,4	32,07
UNJC nº 10-24h	4,83	3,90	R	70 x 15 x 6,0 x 4,9	33,71
UNJC nº 12-24h	5,49	4,50	R	80 x 16 x 6,0 x 4,9	35,36
UNJC 1/4-20h	6,35	5,10	R	80 x 17 x 7,0 x 5,5	31,45
UNJC 5/16-18h	7,94	6,60	R	90 x 20 x 8,0 x 6,2	35,59
UNJC 3/8-16h	9,52	8,00	R	100 x 22 x 8,0 x 6,2	40,58

		D1 mm		L1 x L2 x D2 x ∇ mm	MTR
					FORMA C
					€
UNJF nº 4-48h	2,84	2,35	R	56 x 11 x 3,5 x 2,7	36,97
UNJF nº 5-44h	3,17	2,70	R	56 x 11 x 3,5 x 2,7	36,97
UNJF nº 6-40h	3,50	2,95	R	56 x 12 x 4,0 x 3,0	35,36
UNJF nº 8-36h	4,17	3,50	R	63 x 13 x 4,5 x 3,4	35,36
UNJF nº 10-32h	4,83	4,10	R	70 x 15 x 6,0 x 4,9	35,36
UNJF nº 12-28h	5,49	4,60	R	80 x 16 x 6,0 x 4,9	36,97
UNJF 1/4-28h	6,35	5,50	R	80 x 17 x 7,0 x 5,5	28,71
UNJF 5/16-24h	7,94	6,90	R	90 x 20 x 8,0 x 6,2	32,10
UNJF 3/8-24h	9,52	8,50	R	90 x 16 x 7,0 x 6,2	35,15

MANGO DELGADO PASOS NORMALES				MID
UNJC 7/16-14h	11,11	9,40	D 110 x 24 x 9,0 x 7,0	55,95
UNJC 1/2-13h	12,70	10,75	D 110 x 26 x 11,0 x 9,0	60,74
UNJC 9/16-12h	14,28	12,20	D 110 x 27 x 12,0 x 9,0	83,47
UNJC 5/8-11h	15,87	13,50	D 110 x 27 x 12,0 x 9,0	86,10
UNJC 3/4-10h	19,05	16,50	D 125 x 30 x 14,0 x 11,0	107,37
UNJC 7/8-9h	22,22	19,50	D 140 x 32 x 18,0 x 14,5	141,27
UNJC 1"-8h	25,40	22,25	D 160 x 36 x 18,0 x 14,5	186,65

MANGO DELGADO PASOS NORMALES				MID
UNJF 7/16-20h	11,11	9,90	D 100 x 22 x 8,0 x 6,2	48,27
UNJF 1/2-20h	12,70	11,50	D 100 x 22 x 9,0 x 7,0	51,40
UNJF 9/16-18h	14,29	12,90	D 100 x 22 x 11,0 x 9,0	63,15
UNJF 5/8-18h	15,87	14,50	D 100 x 22 x 12,0 x 9,0	71,10
UNJF 3/4-16h	19,05	17,50	D 110 x 25 x 14,0 x 11,0	90,96
UNJF 7/8-14h	22,22	20,40	D 125 x 25 x 18,0 x 14,5	114,39
UNJF 1"-12h	25,40	23,25	D 140 x 28 x 18,0 x 14,5	127,53

BSPB **DIN 2999 55°** **HSSCo 5%** **DIN 374** **FORMA C**

ROSCA CILÍNDRICA INGLESA PARA TUBO

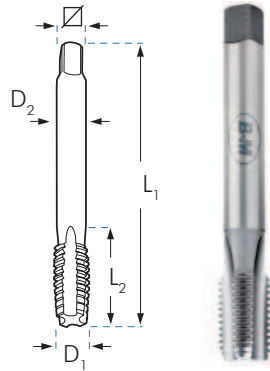

	D1 mm	L1 x L2 x D2 x ∇ mm	€
Rp 1/16-28h.	7,72	D 90 x 16 x 6 x 4,9	
Rp 1/8-28h.	9,73	D 90 x 16 x 7 x 5,5	43,84
Rp 1/4-19h.	13,16	D 100 x 22 x 11 x 9,0	60,55
Rp 3/8-19h.	16,66	D 100 x 22 x 12 x 9,0	72,50
Rp 1/2-14h.	20,95	D 125 x 25 x 16 x 12,0	91,63
Rp 3/4-14h.	26,44	D 140 x 28 x 20 x 16,0	143,49
Rp 1"-11h.	33,25	D 160 x 30 x 25 x 20,0	222,62
Rp 1.1/4-11h.	41,91	D 170 x 30 x 32 x 24,0	
Rp 1.1/2-11h.	46,80	D 190 x 32 x 36 x 29,0	
Rp 2"-11h.	59,61	D 220 x 36 x 45 x 35,0	

BSPT **BS21 ISO7/1 55°** **HSSCo 5%** **DIN 5156** **FORMA C**

ROSCA CÓNICA INGLESA PARA TUBO

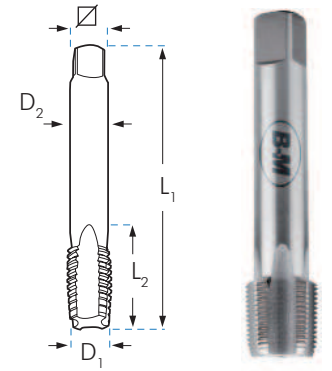

	D1 mm	∇	L1 x L2 x D2 x ∇ mm	€
Rc 1/16-28h.	7,72		D 90 x 14 x 6 x 4	
Rc 1/8-28h.	9,73	8,30	D 90 x 15 x 7 x 5	44,86
Rc 1/4-19h.	13,16	11,00	D 100 x 19 x 11 x 9	64,50
Rc 3/8-19h.	16,66	14,50	D 100 x 21 x 12 x 9	89,65
Rc 1/2-14h.	20,95	18,10	D 125 x 26 x 16 x 12	124,56
Rc 5/8-14h.	22,91	21,00	D 140 x 36 x 18 x 19	200,94
Rc 3/4-14h.	26,44	23,50	D 140 x 28 x 20 x 16	194,27
Rc 7/8-14h.	30,20	28,25	D 160 x 36 x 22 x 18	338,07
Rc 1"-11h.	33,25	29,60	D 160 x 33 x 25 x 20	278,44

NPS (M) **ANSI B 1.20.1 60°** **HSSCo 5%** **DIN 374** **FORMA C**

ROSCA CILÍNDRICA AMERICANA PARA TUBO

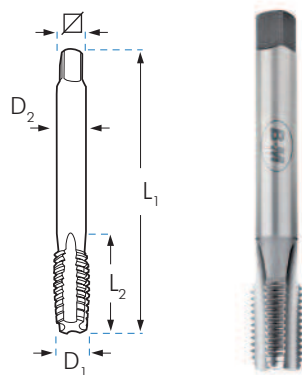

	D1 mm	∇	L1 x L2 x D2 x ∇ mm	€
NPS 1/8-27h.	10,20	8,90	D 90 x 16 x 7 x 5,5	112,92
NPS 1/4-18h.	13,60	11,70	D 100 x 22 x 11 x 9,0	161,61
NPS 3/8-18h.	17,00	15,00	D 100 x 22 x 12 x 9,0	221,61
NPS 1/2-14h.	21,20	18,60	D 125 x 25 x 16 x 12,0	303,89
NPS 3/4-14h.	26,55	24,00	D 140 x 28 x 20 x 16,0	449,24
NPS 1"-11,5 h.	33,20	30,00	D 160 x 30 x 25 x 20,0	580,95
NPS 1.1/4-11,5h.	41,60		D 170 x 30 x 32 x 24,0	
NPS 1.1/2-11,5h.	47,68		D 190 x 32 x 36 x 29,0	
NPS 2"-11,5h.	59,71		D 220 x 36 x 45 x 35,0	

NPT **ANSI B 1.20.1 60°** **HSSCo 5%** **DIN 374** **FORMA C**

ROSCA CÓNICA AMERICANA PARA TUBO

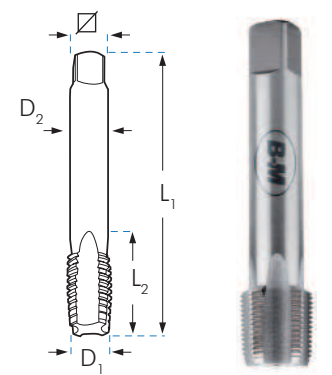

	D1 mm	∇	L1 x L2 x D2 x ∇ mm	€
NPT 1/16-27h.	7,89	6,2	D 90 x 14 x 6 x 5	39,28
NPT 1/8-27h.	10,24	8,5	D 90 x 15 x 8 x 6	39,28
NPT 1/4-18h.	13,62	11,0	D 100 x 19 x 11 x 9	53,06
NPT 3/8-18h.	17,05	14,5	D 100 x 21 x 12 x 9	68,20
NPT 1/2-14h.	21,22	17,8	D 125 x 26 x 16 x 12	88,73
NPT 3/4-14h.	26,57	23,0	D 140 x 28 x 20 x 16	137,47
NPT 1"-11,5h.	33,23	29,0	D 160 x 33 x 25 x 20	178,67
NPT 1.1/4-11,5h.	41,98	37,5	D 170 x 36 x 32 x 24	243,95
NPT 1.1/2-11,5h.	48,05	44,0	D 190 x 37 x 36 x 29	384,13
NPT 2"-11,5h.	60,09	56,0	D 220 x 41 x 45 x 35	602,54

NPSF HSSCo 5% DIN 374 FORMA C

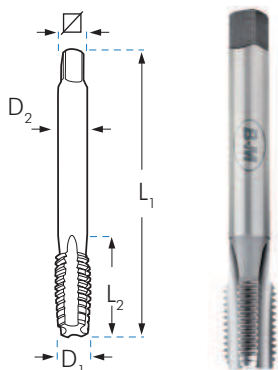
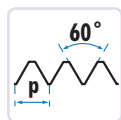

ROSCA PARA TUBO AMERICANA CILÍNDRICA

NPTF HSSCo 5% DIN 374 FORMA C

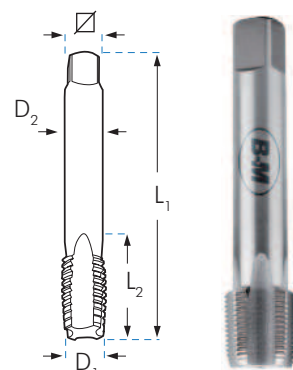
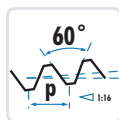

ROSCA PARA TUBO AMERICANA CÓNICA ESTANCA

		D1 mm		L1 x L2 x D2 x ∇ mm	MID €
NPSF	1/8-27h.	10,05	8,75	D 90 x 16 x 7 x 5,5	141,44
NPSF	1/4-18h.	13,33	11,30	D 100 x 22 x 11 x 9,0	194,95
NPSF	3/8-18h.	16,78	14,70	D 100 x 22 x 12 x 9,0	277,34
NPSF	1/2-14h.	20,87	18,20	D 125 x 25 x 16 x 12,0	345,86
NPSF	3/4-14h.	26,23	23,50	D 140 x 28 x 20 x 16,0	566,04
NPSF	1"-11,5h.	32,81	29,50	D 160 x 30 x 25 x 20,0	

		D1 mm		L1 x L2 x D2 x ∇ mm	MID €
NPTF	1/16-27h.	7,87	6,20	D 90 x 14 x 12,0 x 6	
NPTF	1/8-27h.	10,22	8,50	D 90 x 15 x 12,0 x 7	95,56
NPTF	1/4-18h.	13,58	11,00	D 100 x 21 x 17,5 x 11	134,06
NPTF	3/8-18h.	17,02	14,50	D 110 x 21 x 17,6 x 12	172,23
NPTF	1/2-14h.	21,21	17,80	D 140 x 27 x 22,8 x 16	224,21
NPTF	3/4-14h.	26,56	23,00	D 140 x 27 x 23,0 x 20	347,34

MF HSSCo 5% TOL 6H DIN 374 FORMA C

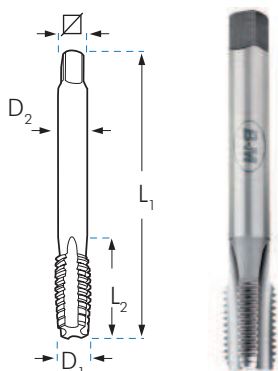
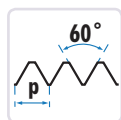

ROSCA MÉTRICA FINA PARA TUBO DE CONDUCCIÓN ELÉCTRICA EN 60423

PG HSSCo 5% DIN 40430 FORMA C

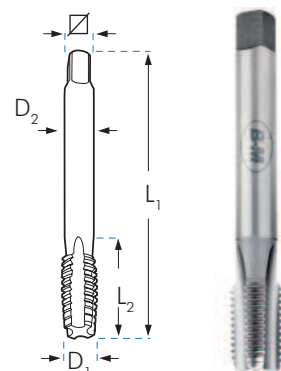
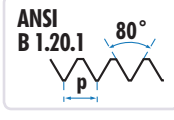

ROSCA PARA TUBO DE CONDUCCIÓN ELÉCTRICA

		D1 mm		L1 x L2 x D2 x ∇ mm	MID €
MF	12 x 1,50	12	10,5	D 100 x 22 x 9 x 7,0	22,42
MF	16 x 1,50	16	14,5	D 100 x 22 x 12 x 9,0	31,57
MF	20 x 1,50	20	18,5	D 125 x 25 x 16 x 12,0	47,34
MF	25 x 1,50	25	23,5	D 140 x 28 x 18 x 14,5	109,04
MF	32 x 1,50	32	30,5	D 150 x 28 x 22 x 18,0	136,10
MF	40 x 1,50	40	38,5	D 170 x 30 x 32 x 24,0	237,57
MF	50 x 1,50	50	48,5	D 190 x 32 x 36 x 29,0	356,91
MF	63 x 1,50	63	61,5	D 275 x 36 x 50 x 39,0	

		D1 mm		L1 x L2 x D2 x ∇ mm	MID €
PG	7 - 20h.	12,5	11,50	D 100 x 22 x 9 x 7,0	41,93
PG	9 - 18h.	15,2	14,00	D 100 x 22 x 12 x 9,0	58,07
PG	11 - 18h.	18,6	17,25	D 110 x 25 x 14 x 11,0	75,56
PG	13,5 - 18h.	20,4	19,00	D 125 x 25 x 16 x 12,0	84,85
PG	16 - 18h.	22,5	21,25	D 125 x 25 x 18 x 14,5	99,86
PG	21 - 16h.	28,3	27,00	D 150 x 28 x 22 x 18,0	158,53
PG	29 - 16h.	37,0	35,50	D 170 x 30 x 28 x 22,0	268,00
PG	36 - 16h.	47,0	45,50	D 190 x 32 x 36 x 29,0	435,24
PG	42 - 16h.	54,0	52,50	D 190 x 32 x 40 x 32,0	691,25
PG	48 - 16h.	59,3	58,00	D 220 x 36 x 45 x 35,0	842,69

UNx8 HSSCo 5% DIN 374 FORMA C TOL 2B

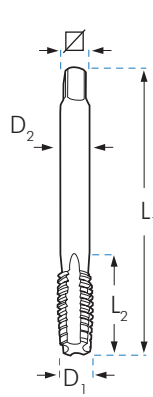
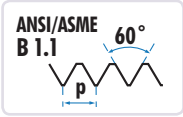

UNEF HSSCo 5% DIN 374 TOL 2B

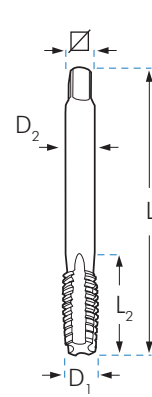
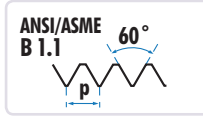

				M1D	
			D2 mm	L1 x L2 x	€
UN 1" 1/8-8h.	25,40	22	180 x 45 x 18	208,46	
UN 1" 1/4-8h.	28,50	22	180 x 48 x 18	268,94	
UN 1" 3/8-8h.	31,75	28	200 x 56 x 22	305,09	
UN 1" 1/2-8h.	35,00	32	200 x 58 x 22	388,16	
UN 1" 5/8-8h.	38,10	32	200 x 65 x 24	454,06	
UN 1" 3/4-8h.	41,25	36	200 x 50 x 29	553,12	
UN 1" 7/8-8h.	44,45	36	225 x 53 x 29	638,03	
UN 2"-8h.	47,63	40	225 x 50 x 32	651,92	

					M2D	M4D
					FORMA B	
			D2 mm	L1 x L2 x	€	€
UNEF 1/4-32h.	5,55	7,0	R 82 x 16 x 5,4	86,25	96,93	
UNEF 5/16-32h.	7,15	8,4	R 85 x 21 x 6,1	95,04	106,79	
UNEF 3/8-32h.	8,70	7,0	D 95 x 22 x 5,4	95,09	106,84	
UNEF 7/16-28h.	10,20	8,0	D 100 x 22 x 6,2	126,22	141,82	
UNEF 1/2-28h.	11,80	9,0	D 100 x 22 x 7,0	132,95	149,37	
UNEF 9/16-24h.	13,20	12,0	D 100 x 24 x 9,0	166,56	187,14	
UNEF 5/8-24h.	14,80	12,0	D 100 x 24 x 9,0	189,53	212,96	
UNEF 3/4-20h.	17,80	14,0	D 110 x 27 x 11,0	246,51	276,99	
UNEF 7/8-20h.	20,95	18,0	D 125 x 26 x 14,5	264,97	283,90	
UNEF 1"-20h.	24,20	18,0	D 140 x 28 x 14,5	405,50	455,62	

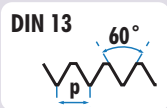

HSSCo
5%

ISO
529

TOL
6H

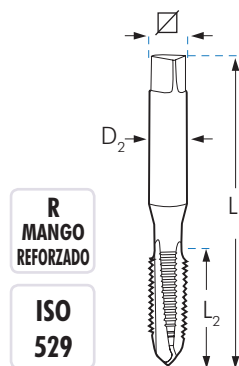
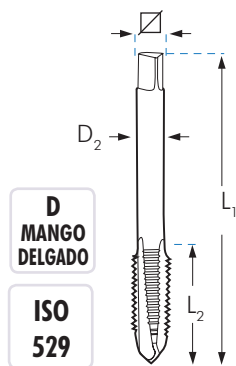

Forma	D	L1	L2	D2	L1 x L2 x D2 x mm	M1RISO	M2RISO	M4RISO	M5RISO
						FORMA C	FORMA B	35°	DIENTE ALTERNO AI
						€	€	€	€
M	3x0,50	2,50	R	48 x 11 x 3,15 x 2,50		7,08	7,37	8,88	10,56
M	4x0,70	3,30	R	53 x 13 x 4,00 x 3,15		7,08	7,37	8,88	10,56
M	5x0,80	4,20	R	58 x 16 x 5,00 x 4,00		7,08	7,37	8,88	10,56
M	6x1,00	5,00	R	66 x 19 x 6,30 x 5,00		7,08	7,37	9,07	10,56
M	7x1,00	6,00	R	66 x 19 x 7,10 x 5,60			10,49	12,04	
M	8x1,00	7,00	D	69 x 19 x 8,00 x 6,30			14,47	14,08	
M	8x1,25	6,75	R	72 x 22 x 8,00 x 6,30		9,45	9,84	10,18	11,54
M	9x1,25	7,75	R	76 x 20 x 10,00 x 8,00			15,66	17,88	
M	10x1,00	9,00	D	76 x 20 x 10,00 x 8,00			16,60	18,13	
M	10x1,25	8,80	D	76 x 20 x 10,00 x 8,00			19,84	19,76	
M	10x1,50	8,50	R	80 x 24 x 10,00 x 8,00		12,02	12,52	13,12	14,56
MANGO DELGADO						M1DISO	M2DISO	M4DISO	M5DISO
M	12x1,00	11,00	D	84 x 24 x 9,00 x 7,10			22,87	23,43	
M	12x1,25	10,75	D	84 x 24 x 9,00 x 7,10			22,46	22,44	
M	12x1,50	10,50	D	89 x 29 x 9,00 x 7,10			20,04	21,58	
M	12x1,75	10,20	D	89 x 29 x 9,00 x 7,10		15,45	16,09	17,05	21,78
M	14x1,00	13,00	D	90 x 25 x 11,20 x 9,00			28,64	35,62	
M	14x1,25	12,80	D	90 x 25 x 11,20 x 9,00			24,19	30,28	
M	14x1,50	12,50	D	95 x 30 x 12,50 x 9,00			21,25	23,88	
M	14x2,00	12,00	D	95 x 30 x 11,20 x 9,00		18,47	19,24	23,29	
M	16x1,00	15,00	D	95 x 25 x 12,50 x 10,00			36,44	46,89	
M	16x1,25	14,75	D	102 x 32 x 12,50 x 10,00			40,40	52,00	
M	16x1,50	14,50	D	102 x 32 x 14,00 x 10,00			25,50	28,58	
M	16x2,00	14,00	D	102 x 32 x 12,50 x 10,00		22,94	23,89	27,02	
M	18x1,50	16,50	D	104 x 29 x 14,00 x 11,20			33,70	46,04	
M	18x2,50	15,50	D	112 x 37 x 14,00 x 11,20		34,53	35,97	44,97	
M	20x1,50	18,50	D	104 x 29 x 14,00 x 11,20			43,36	53,03	
M	20x2,50	17,50	D	112 x 37 x 14,00 x 11,20		38,60	40,21	50,26	
M	22x2,50	19,50	D	118 x 38 x 16,00 x 12,50		44,63	46,49	58,12	
M	24x3,00	21,00	D	130 x 45 x 18,00 x 14,00		50,43	52,53	65,66	
M	27x3,00	24,00	D	135 x 45 x 20,00 x 16,00		62,09	64,68	80,85	
M	30x3,50	26,50	D	138 x 48 x 20,00 x 16,00		92,25	96,10	120,12	

M
MF

DIN 13

HSS

HSSCo
5%

DIN
352

TOL
6H



		L1 x L2 x D2 x \square mm	M03	M02AT	M03X	M02DIN	M04DIN
			FORMA C	ALTURA TERMINADA	INOX	FORMA B	35°
			HSS	HSS	HSSCo	HSS	HSS
			€	€	€	€	€
M 3x0,50	2,50	D 40 x 11 x 3,50 x 2,70	6,37	8,60	10,47	8,11	9,77
M 4x0,70	3,30	D 45 x 13 x 4,50 x 3,40	6,36	8,59	10,47	8,11	9,77
M 5x0,80	4,20	D 50 x 16 x 6,00 x 4,90	6,81	9,19	10,90	8,11	9,77
M 6x1,00	5,00	D 50 x 19 x 6,00 x 4,90	6,81	9,19	10,87	8,11	9,98
M 7x1,00	6,00	D 50 x 19 x 6,00 x 4,90	8,29				
M 8x1,00	7,00	D 56 x 18 x 6,00 x 4,90	11,47				
M 8x1,25	6,75	D 56 x 22 x 6,00 x 4,90	8,28	11,18	12,65	10,83	12,10
M 9x1,25	7,75	D 63 x 18 x 7,00 x 5,50	13,57				
M 10x1,00	9,00	D 63 x 18 x 7,00 x 5,50	12,28				
M 10x1,25	8,80	D 70 x 24 x 7,00 x 5,50	12,45				
M 10x1,50	8,50	D 70 x 24 x 7,00 x 5,50	10,21	13,78	16,27	13,77	15,25
M 12x1,00	11,00	D 70 x 20 x 9,00 x 7,00	21,78				
M 12x1,25	10,75	D 70 x 20 x 9,00 x 7,00	21,71				
M 12x1,50	10,50	D 70 x 20 x 9,00 x 7,00	18,50				
M 12x1,75	10,20	D 75 x 29 x 9,00 x 7,00	14,37	19,40	23,30	17,70	19,85
M 14x1,00	13,00	D 70 x 20 x 11,00 x 9,00	33,03				
M 14x1,25	12,80	D 70 x 20 x 11,00 x 9,00	26,51				
M 14x1,50	12,50	D 70 x 20 x 11,00 x 9,00	20,62				
M 14x2,00	12,00	D 80 x 30 x 11,00 x 9,00	15,90	21,46	25,81	21,16	25,62
M 16x1,00	15,00	D 70 x 20 x 12,00 x 9,00	45,02				
M 16x1,25	14,75	D 70 x 20 x 12,00 x 9,00	47,39				
M 16x1,50	14,50	D 70 x 20 x 12,00 x 9,00	25,65				
M 16x2,00	14,00	D 80 x 32 x 12,00 x 9,00	22,55		35,37	26,28	29,72
M 18x1,50	16,50	D 80 x 22 x 14,00 x 11,00	33,80				
M 18x2,50	15,50	D 95 x 40 x 14,00 x 11,00	29,76		48,30	39,57	49,47
M 20x1,50	18,50	D 80 x 22 x 16,00 x 12,00	42,33				
M 20x2,50	17,50	D 95 x 40 x 16,00 x 12,00	33,39		53,61	44,23	55,28
M 22x2,50	19,50	D 100 x 40 x 18,00 x 14,50	44,84			51,14	63,93
M 24x3,00	21,00	D 110 x 50 x 18,00 x 14,50	53,05			57,78	72,22
M 27x3,00	24,00	D 110 x 50 x 20,00 x 16,00	67,63			74,58	81,87
M 30x3,50	26,50	D 125 x 50 x 22,00 x 18,00	87,04			95,82	104,92

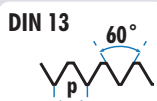

TOL
6H

PARA TRABAJOS DE ALTA PRODUCCIÓN
FABRICADOS EN ACERO SINTERIZADO

DIN
22568

TOL
6g

Plus Super Plus

Vc
14 m/min

Vc
16 m/min

Vc
17 m/min

Vc
20 m/min

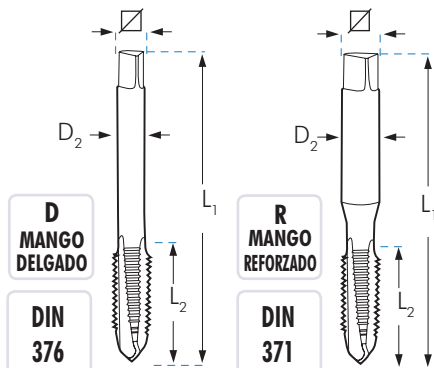

ROSCA LAPEADA Y ROMPEVIRUTAS

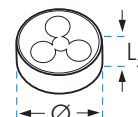

Plus Plus TiN Plus LUBE Super Plus ALTiN

CALIDAD	Plus		Plus TiN		Plus LUBE		Super Plus ALTiN		CSP			
	M2RP	M4RP	M2RT	M4RT	M2RHL	M4RHL	M2RSP	M4RSP		CSP		
MATERIAL	HSS PM	HSS PM	HSSCo 5%	HSSCo 5%	HSS PM	HSS PM	HSS V3	HSS V3		HSS		
ACABADO	BRILLANTE	BRILLANTE	TiN	TiN	HARD LUBE	HARD LUBE	ALTiN	ALTiN		BRILLANTE		
ÁNGULO DE HÉLICE	FORMA B	FORMA B 35°	FORMA B	FORMA B 35°	FORMA B	FORMA B 35°	FORMA B	FORMA B 41°				
	L1 x L2 x D2 x Ø								Ø x L3			
	€	€	€	€	€	€	€	€	mm	€		
M 3x0,50	2,50 R	56 x 11 x 3,5 x 2,7	13,97	17,27	18,81	20,78	25,65	27,27	32,38	33,59	25 x 9	26,68
M 4x0,70	3,30 R	63 x 13 x 4,5 x 3,4	14,27	17,27	19,11	21,68	25,57	27,65	32,38	33,59	25 x 9	26,68
M 5x0,80	4,20 R	70 x 16 x 6,0 x 4,9	14,27	16,55	19,11	21,56	24,99	27,65	34,19	34,83	25 x 9	26,68
M 6x1,00	5,00 R	80 x 17 x 6,0 x 4,9	15,70	18,17	22,00	23,82	28,08	29,26	34,19	34,83	25 x 9	26,68
M 8x1,00	7,00 D	90 x 20 x 6,0 x 4,9	22,40	26,57	31,54	35,10	42,59	47,39			25 x 9	37,20
M 8x1,25	6,80 R	90 x 20 x 8,0 x 6,2	17,58	20,73	25,73	27,97	35,70	35,01	43,40	45,85	25 x 9	28,94
M 10x1,00	9,00 D	90 x 16 x 7,0 x 5,5	24,97	31,32	36,84	42,30	49,73	58,75			38 x 10	45,46
M 10x1,50	8,50 R	100 x 22 x 10,0 x 8,0	21,61	24,58	30,29	33,17	44,26	43,56	51,73	54,70	38 x 10	39,78
MANGO DELGADO												
		M2DP	M4DP	M2DT	M4DT	M2DHL	M4DHL	M2DSP	M4DSP			
M 12x1,50	10,50 D	100 x 22 x 9,0 x 7,0	29,63	35,82	39,19	44,13	55,65	63,84			38 x 10	47,27
M 12x1,75	10,20 D	110 x 24 x 9,0 x 7,0	27,86	33,09	36,68	41,36	48,50	58,20	65,08	69,99	38 x 14	41,73
M 14x1,50	12,50 D	100 x 22 x 11,0 x 9,0	35,10	44,01	46,10	50,90	65,46	75,06			38 x 10	49,42
M 14x2,00	12,00 D	110 x 26 x 11,0 x 9,0	34,84	40,38	45,27	49,76	66,15	72,71	66,45	88,69	38 x 14	42,54
M 16x1,50	14,50 D	100 x 22 x 12,0 x 9,0	43,91	54,14	55,39	63,34	61,17	75,45			45 x 14	67,87
M 16x2,00	14,00 D	110 x 27 x 12,0 x 9,0	40,96	48,81	51,68	57,13	75,52	83,47	90,70	95,65	45 x 18	57,14
M 18x2,50	15,50 D	125 x 30 x 14,0 x 11,0	58,08	65,61	70,57	76,99	98,34	107,29	134,62	144,40	45 x 18	57,14
M 20x2,50	17,50 D	140 x 32 x 16,0 x 12,0	62,74	69,93	80,43	86,66	112,09	120,79	143,47	150,35	45 x 18	57,14
M 22x2,50	19,50 D	140 x 32 x 18,0 x 14,5	75,91	86,30	90,90	97,29	131,47	143,47			55 x 22	84,95
M 24x3,00	21,00 D	160 x 34 x 18,0 x 14,5	90,25	103,31	102,42	111,29	148,14	164,10			55 x 22	84,95

INOX

M

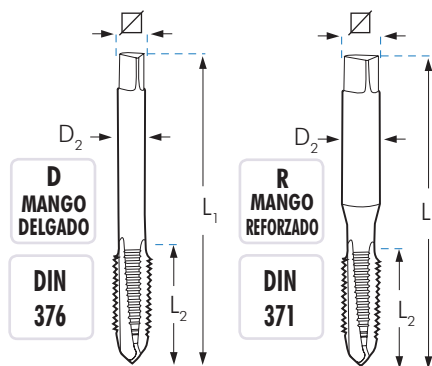
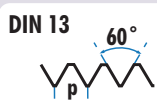

Vc
6 m/min

Vc
10 m/min

Vc
12 m/min



			M2RX	M4RX	M2RXT	M4RXT	M2RXHL	M4RXHL
CALIDAD			★★	★★	★★★	★★★	★★★★	★★★★
MATERIAL			HSS PM	HSS PM	HSSCo 5%	HSSCo 5%	HSS PM	HSS PM
ACABADO			OX	OX	TiN	TiN	HARD LUBE	HARD LUBE
ÁNGULO DE HÉLICE			FORMA B	FORMA B 35°	FORMA B	FORMA B 35°	FORMA B	FORMA B 35°
		L1 x L2 x D2 x \square mm	€	€	€	€	€	€
M 3x0,50	2,50	R 56 x 11 x 3,5 x 2,7	15,97	19,66	18,44	20,87	24,39	28,69
M 4x0,70	3,30	R 63 x 13 x 4,5 x 3,4	16,77	19,66	19,35	21,21	25,62	29,44
M 5x0,80	4,20	R 70 x 16 x 6,0 x 4,9	16,77	18,80	19,35	21,53	25,62	29,88
M 6x1,00	5,00	R 80 x 17 x 6,0 x 4,9	18,38	20,67	20,49	22,51	28,06	31,27
M 8x1,25	6,80	R 90 x 20 x 8,0 x 6,2	20,50	23,56	23,68	25,94	31,33	36,00
M 10x1,50	8,50	R 100 x 22 x 10,0 x 8,0	25,06	27,95	27,68	30,59	38,27	42,69
MANGO DELGADO			M2DX	M4DX	M2DXT	M4DXT	M2DXHL	M4DXHL
M 12x1,75	10,20	D 110 x 24 x 9,0 x 7,0	32,20	37,71	35,41	39,87	48,30	56,54
M 14x2,00	12,00	D 110 x 26 x 11,0 x 9,0	45,84	50,33	46,14	49,87	64,19	71,07
M 16x2,00	14,00	D 110 x 27 x 12,0 x 9,0	51,05	58,09	50,18	54,99	71,46	85,96
M 18x2,50	15,50	D 125 x 30 x 14,0 x 11,0	76,46	82,65	78,94	79,84	114,67	122,30
M 20x2,50	17,50	D 140 x 32 x 16,0 x 12,0	82,62	87,28	90,13	92,55	121,91	129,14
M 22x2,50	19,50	D 140 x 32 x 18,0 x 14,5			102,94	111,45		
M 24x3,00	21,00	D 160 x 34 x 18,0 x 14,5			114,06	123,91		



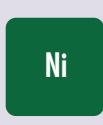
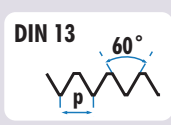

Ref. ACXT00250

- Lubricación: **CUT MAGIC XTHICK**
- Se recomienda la aplicación del Aceite de corte CUT MAGIC XTHICK para optimizar el proceso de roscado en Inoxidables, Inconel, Titanio, Dúplex, etc...

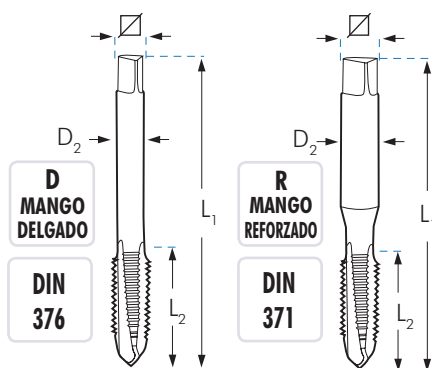

ESPECIALMENTE RECOMENDADOS
EN APLICACIONES AERONAÚTICAS



		M2RDU	M4RDU	M2RNI	M3RNI	M2RTIT	M3RTIT	
CALIDAD		★★★★	★★★★	★★★★	★★★★	★★★★	★★★★	
MATERIAL		HSS V3	HSS V3	HSS PM	HSS PM	HSS PM	HSS PM	
ACABADO		TiCN	TiCN	BRILLANTE	BRILLANTE	OX	OX	
ÁNGULO DE HÉLICE		FORMA B	41°	FORMA B	15°	FORMA B	15°	
		L1 x L2 x D2 x \square mm	€	€	€	€	€	
M 3x0,50	2,50	R 56 x 11 x 3,5 x 2,7	33,71	35,15	62,63	63,99	46,50	51,32
M 4x0,70	3,30	R 63 x 13 x 4,5 x 3,4	33,71	34,43	63,99	65,72	47,94	51,32
M 5x0,80	4,20	R 70 x 16 x 6,0 x 4,9	34,83	35,52	66,25	67,81	49,15	54,66
M 6x1,00	5,00	R 80 x 17 x 6,0 x 4,9	35,80	36,56	66,77	68,66	49,15	55,43
M 8x1,25	6,80	R 90 x 20 x 8,0 x 6,2	50,00	52,13	75,46	77,47	56,79	63,99
M 10x1,50	8,50	R 100 x 22 x 10,0 x 8,0	64,80	66,49	89,66	92,39	70,35	77,11
MANGO DELGADO		M2DDU	M4DDU	M2DNI	M3DNI	M2DTIT	M3DTIT	
M 12x1,75	10,20	D 110 x 24 x 9,0 x 7,0	87,60	94,60	115,32	127,50	88,29	95,81
M 14x2,00	12,00	D 110 x 26 x 11,0 x 9,0						
M 16x2,00	14,00	D 110 x 27 x 12,0 x 9,0	128,83	137,76				
M 18x2,50	15,50	D 125 x 30 x 14,0 x 11,0						
M 20x2,50	17,50	D 140 x 32 x 16,0 x 12,0	190,77	206,06				
M 22x2,50	19,50	D 140 x 32 x 18,0 x 14,5						
M 24x3,00	21,00	D 160 x 34 x 18,0 x 14,5	258,39	262,81				
M 27x3,00	24,00	D 160 x 36 x 20,0 x 16,0	331,95	347,96				
M 30x3,50	26,50	D 180 x 40 x 22,0 x 18,0	392,05	410,23				

DIN 13
HSSCo 5%
OX
TOL 6H

APLICACIONES

450 N/mm²
ST52
AI

Geometría de corte específica para materiales blandos, no genera SOBREMEDIDA y se ajusta perfectamente a este tipo de materiales donde los machos convencionales, pueden provocar agrandamientos a la hora de generar la rosca.

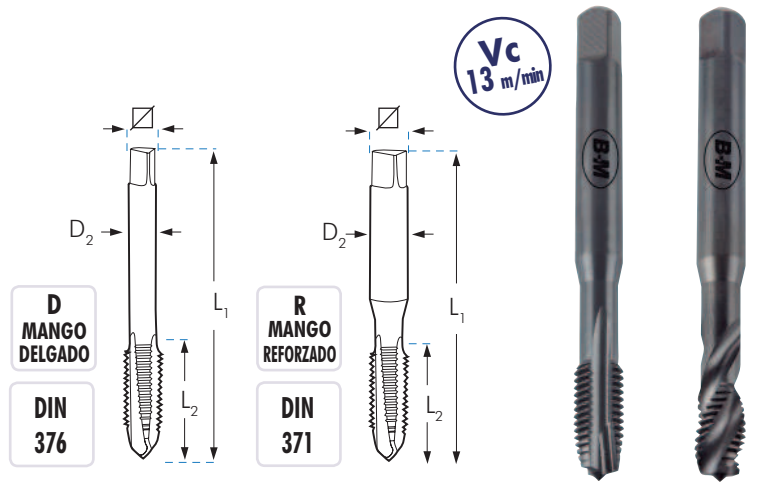

		L ₁ x L ₂ x D ₂ x	M2RSS	M4RSS
			FORMA B	
			€	€
M 3 x 0,50	2,50	R 56 x 11 x 3,5 x 2,7	12,46	16,33
M 4 x 0,70	3,30	R 63 x 13 x 4,5 x 3,4	13,03	16,34
M 5 x 0,80	4,20	R 70 x 16 x 6,0 x 4,9	13,06	15,67
M 6 x 1,00	5,00	R 80 x 17 x 6,0 x 4,9	14,32	17,18
M 8 x 1,25	6,80	R 90 x 20 x 8,0 x 6,2	16,07	19,44
M 10 x 1,50	8,50	R 100 x 22 x 10,0 x 8,0	19,79	23,02
MANGO DELGADO			M2DSS	M4DSS
M 12 x 1,75	10,20	D 110 x 24 x 9,0 x 7,0	24,95	29,65
M 14 x 2,00	12,00	D 110 x 26 x 11,0 x 9,0	36,84	42,69
M 16 x 2,00	14,00	D 110 x 27 x 12,0 x 9,0	43,09	51,57
M 18 x 2,50	15,50	D 125 x 30 x 14,0 x 11,0	61,39	66,87
M 20 x 2,50	17,50	D 140 x 32 x 16,0 x 12,0	66,27	74,12
M 22 x 2,50	19,50	D 140 x 32 x 18,0 x 14,5	79,54	86,99
M 24 x 3,00	21,00	D 160 x 34 x 18,0 x 14,5	94,75	105,74
M 27 x 3,00	24,00	D 160 x 36 x 20,0 x 16,0	118,51	130,10
M 30 x 3,50	26,50	D 180 x 40 x 22,0 x 18,0	152,26	166,73

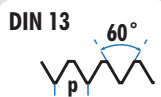

HSS V3

TOL 6H

MATERIALES DUROS

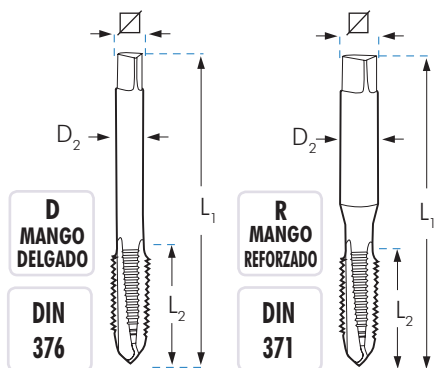

Vc 7 m/min

Vc 9 m/min



		M2RMD	M4RMD	M2RMDTX	M4RMDTX	
CALIDAD		★★★	★★★	★★★★	★★★★	
MATERIAL		HSS V3	HSS V3	HSS V3	HSS V3	
ACABADO		OX	OX	TINALOX	TINALOX	
ÁNGULO DE HÉLICE		FORMA B	35°	FORMA B	35°	
		L ₁ x L ₂ x D ₂ x	€	€	€	€
M 3x0,50	2,50	R 56 x 11 x 3,5 x 2,7	14,53	15,90	21,30	25,05
M 4x0,70	3,30	R 63 x 13 x 4,5 x 3,4	14,31	15,81	22,38	26,23
M 5x0,80	4,20	R 70 x 16 x 6,0 x 4,9	14,31	16,58	22,38	26,23
M 6x1,00	5,00	R 80 x 17 x 6,0 x 4,9	16,54	17,29	24,51	27,57
M 8x1,25	6,80	R 90 x 20 x 8,0 x 6,2	17,67	20,40	27,36	31,45
M 10x1,50	8,50	R 100 x 22 x 10,0 x 8,0	20,36	23,50	34,63	38,62
MANGO DELGADO		M2DMD	M4DMD	M2DMDTX	M4DMDTX	
M 12x1,75	10,20	D 110 x 24 x 9,0 x 7,0	28,01	32,31	44,50	52,10
M 14x2,00	12,00	D 110 x 26 x 11,0 x 9,0	36,75	38,36	63,33	69,53
M 16x2,00	14,00	D 110 x 27 x 12,0 x 9,0	41,10	46,40	70,55	84,09
M 18x2,50	15,50	D 125 x 30 x 14,0 x 11,0	61,28	66,02	103,70	117,45
M 20x2,50	17,50	D 140 x 32 x 16,0 x 12,0	66,23	69,70	112,08	123,98

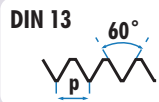

TiCN

TOL 6H

HSS PM

MATERIALES MUY DUROS

48 HRC

48-62 HRC

Vc 5 m/min

MD

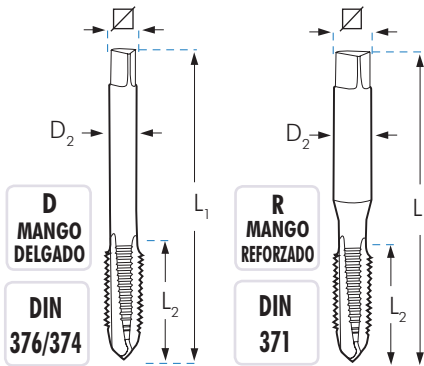

Icon	Type	L1 x L2 x D2 x \square mm	M2RC M3RC M2HRC M4HRC				M1RHMC	
			FORMA B €	15° €	FORMA B €	35° €	FORMA C €	€
M 2 x 0,40	1,60	R 40 x 9 x 2,5 x 2,1			33,25	36,36	1,70	
M 3 x 0,50	2,50	R 56 x 11 x 3,5 x 2,7	30,34	32,28	30,34	33,98	2,60	99,51
M 4 x 0,70	3,30	R 63 x 13 x 4,5 x 3,4	31,51	34,38	31,51	35,29	3,40	99,51
M 5 x 0,80	4,20	R 70 x 16 x 6,0 x 4,9	31,81	33,59	31,81	35,63	4,30	99,51
M 6 x 1,00	5,00	R 80 x 17 x 6,0 x 4,9	33,18	39,03	33,18	37,16	5,10	124,39
M 8 x 1,25	6,80	R 90 x 20 x 8,0 x 6,2	38,33	43,73	41,25	46,20	6,90	140,00
M 10 x 1,50	8,50	R 100 x 22 x 10,0 x 8,0	45,88	54,18	49,37	51,83	8,60	214,81
MANGO DELGADO			M2DC	M3DC	M2HDC	M4HDC	M1DHMC	
M 12 x 1,75	10,20	D 110 x 24 x 9,0 x 7,0	68,61	106,49	75,36	82,14	10,40	336,42
M 14 x 2,00	12,00	D 110 x 26 x 11,0 x 9,0	92,63	108,34	89,36	97,40	12,10	387,66
M 16 x 2,00	14,00	D 110 x 27 x 12,0 x 9,0	104,52	124,45	99,36	108,30	16,10	506,20
M 18 x 2,50	15,50	D 125 x 30 x 14,0 x 11,0	132,35	188,45	105,10	114,56	15,75	618,42
M 20 x 2,50	17,50	D 140 x 32 x 16,0 x 12,0	209,60	218,15	145,25	158,32	17,75	978,24
M 22 x 2,50	19,50	D 140 x 32 x 18,0 x 14,5			179,36	196,36		
M 24 x 3,00	21,00	D 160 x 34 x 18,0 x 14,5			196,36	214,03		
M 27 x 3,00	24,00	D 160 x 36 x 20,0 x 16,0			245,25	276,36		
M 30 x 3,50	26,50	D 180 x 40 x 22,0 x 18,0			301,25	325,36		

HRC	Vc (m/min)
48 Hrc	8 m/min
56 Hrc	6 m/min
62Hrc	3 m/min

- Lubricación: **CUT MAGIC XTHICK**
- Se recomienda roscar la pieza sobre el mismo utillaje utilizado para el taladro previo y en la misma posición, para garantizar coaxialidad entre macho y orificio previo.



Ref. ACXT00250

TODO TERRENO

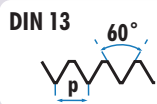

HSSCo
5%

TiN

TOL
6H

APLICACIONES

1200
N/mm²

Al

FUNDICIÓN

Ti

INOX

Vc
13 m/min

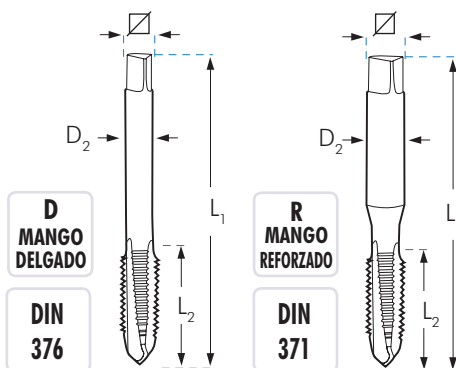

		L ₁ x L ₂ x D ₂ x mm	M2RD	M4RD
			FORMA B	
			€	€
M 3 x 0,50	2,50	R 56 x 11 x 3,5 x 2,7	22,84	28,55
M 4 x 0,70	3,30	R 63 x 13 x 4,5 x 3,4	24,44	28,55
M 5 x 0,80	4,20	R 70 x 16 x 6,0 x 4,9	26,00	29,57
M 6 x 1,00	5,00	R 80 x 17 x 6,0 x 4,9	26,91	30,70
M 8 x 1,25	6,80	R 90 x 20 x 8,0 x 6,2	31,52	35,03
M 10 x 1,50	8,50	R 100 x 22 x 10,0 x 8,0	36,37	41,49
MANGO DELGADO			M2DD	M4DD
M 12 x 1,75	10,20	D 110 x 24 x 9,0 x 7,0	45,83	54,56
M 14 x 2,00	12,00	D 110 x 26 x 11,0 x 9,0	59,86	65,77
M 16 x 2,00	14,00	D 110 x 27 x 12,0 x 9,0	67,07	72,59
M 18 x 2,50	15,50	D 125 x 30 x 14,0 x 11,0	104,81	107,47
M 20 x 2,50	17,50	D 140 x 32 x 16,0 x 12,0	106,75	110,76

Al

FUNDICIÓN

LATÓN

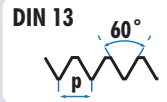

HSSCo 5%

TOL 6H

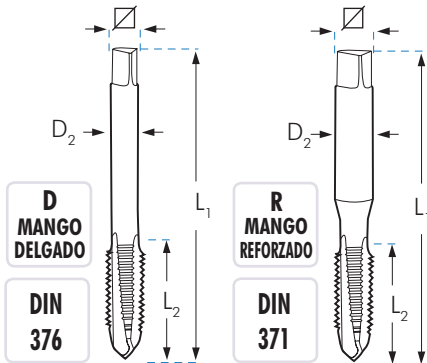

Vc 18 m/min



Vc 11 m/min



Vc 21 m/min



Vc 16 m/min



Vc 19 m/min



APLICACIÓN		M5R	M6R	M1RFM	M1R	M1RL	M1RLCRN	
MATERIAL		Al	Al	FUNDICIÓN	FUNDICIÓN	LATÓN	LATÓN	
ACABADO		HSSCo 5%	HSSCo 5%	HSSCo 5%	MD	HSSCo 5%	HSSCo 5%	
FORMA		BRILLANTE	BRILLANTE	OX	BRILLANTE	BRILLANTE	CrN	
FORMA		DIENTE ALTERNO	2 CANALES	FORMA C	FORMA C	FORMA C	FORMA C	
		€	€	€	€	€	€	
L1 x L2 x D2 x ∇ mm								
M 3x0,50	2,50	R 56 x 11 x 3,5 x 2,7	19,71	21,15	13,94	70,68	16,70	18,96
M 4x0,70	3,30	R 63 x 13 x 4,5 x 3,4	19,81	21,15	14,42	70,68	17,72	20,90
M 5x0,80	4,20	R 70 x 16 x 6,0 x 4,9	19,71	21,59	14,42	70,68	17,72	20,98
M 6x1,00	5,00	R 80 x 17 x 6,0 x 4,9	20,77	23,35	16,37	80,62	19,43	22,91
M 8x1,25	6,80	R 90 x 20 x 8,0 x 6,2	24,86	27,98	18,33	90,01	22,14	27,86
M 10x1,50	8,50	R 100 x 22 x 10,0 x 8,0	29,98	33,09	20,97	112,80	26,64	33,89
MANGO DELGADO		M5D	M6D	M1DFM	M1D	M1DL	M1DLCRN	
M 12x1,75	10,20	D 110 x 24 x 9,0 x 7,0	37,40	40,82	26,38	154,46	31,08	40,96
M 14x2,00	12,00	D 110 x 26 x 11,0 x 9,0	67,73	70,49	43,35	240,63	38,16	49,92
M 16x2,00	14,00	D 110 x 27 x 12,0 x 9,0	73,82	79,94	51,01	286,27	43,90	55,81
M 18x2,50	15,50	D 125 x 30 x 14,0 x 11,0			71,36	350,91	57,58	70,69
M 20x2,50	17,50	D 140 x 32 x 16,0 x 12,0			71,63	424,94	64,63	78,70



- Lubricación: **CUT MAGIC ALUMINIO**
- Se recomienda la aplicación del Aceite de corte CUT MAGIC ALUMINIO para optimizar el proceso de roscado en Aluminio y sus fundiciones.

Ref. ACAL00250

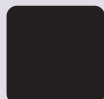
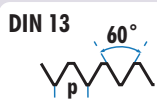

HSSCo
8%

TOL
6HX

APLICACIONES



Plus

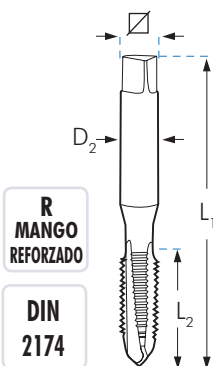

				M07R	M07RT	M07RCR	M07RCCR	M09RCCR	M07RXTCR
APLICACIÓN		LAMINACION		LAMINACION	LAMINACION	LAMINACION	LAMINACION	LAMINACION	LAMINACION
MATERIAL		HSSCo 5%	HSSCo 5%	HSSCo 5%	HSSCo 5%	HSSCo 5%	HSSCo 5%	HSSCo 8%	HSSCo 5%
ACABADO		OX	TiN	OX	TiCN	TiCN	TiCN	TiCN	TiN
FORMA									
		L1 x L2 x D2 x \square mm	€	€	€	€	€	€	€
M 3x0,50	2,75	R 56 x 11 x 3,5 x 2,7	27,14	29,45	29,04	33,10	89,29	66,59	
M 3,5x0,60	3,20	R 56 x 11 x 3,5 x 2,7	28,52	32,49	30,00	35,03			
M 4x0,70	3,65	R 63 x 13 x 4,5 x 3,4	27,14	30,72	29,04	34,52	90,42	66,59	
M 5x0,80	4,60	R 70 x 16 x 6,0 x 4,9	27,14	30,72	29,04	34,52	91,63	71,87	
M 6x1,00	5,50	R 80 x 17 x 6,0 x 4,9	29,30	32,47	31,33	36,48	93,07	71,87	
M 8x1,25	7,40	R 90 x 20 x 8,0 x 6,2	34,14	42,85	36,53	48,16	103,25	86,01	
M 10x1,50	9,30	R 100 x 22 x 10,0 x 8,0	37,97	48,05	40,63	53,01	123,28	105,00	

				M07D	M07DT	M07DCR	M07DCCR	M09DCCR	M07DXTCR
MANGO DELGADO									
M 12x1,75	11,20	D 110 x 24 x 9,0 x 7,0	44,75	62,83	46,10	60,70	145,93	136,73	
M 14x2,00	13,05	D 110 x 26 x 11,0 x 9,0	80,68	99,23	81,50	98,54	181,60	196,70	
M 16x2,00	15,05	D 110 x 27 x 12,0 x 9,0	94,72	111,76	95,67	100,14	249,78	200,11	
M 18x2,50	16,80	D 125 x 30 x 14,0 x 11,0	108,69	133,63	109,78	123,26	295,96		
M 20x2,50	18,80	D 140 x 32 x 16,0 x 12,0	143,21	202,29	144,66	172,97	327,65		

HSSCo 5%	TOL 4H	TOL 6G	TOL 7G	TOL 6H (+0,1)	TOL 6H (+0,2)
---------------------	-------------------	-------------------	-------------------	--------------------------	--------------------------

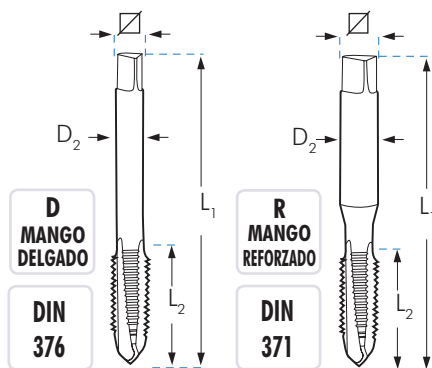

		M2R4H	M4R4H	M2R6G	M4R6G	M2R7G	M4R7G	M2R+0,1	M4R+0,1	M2R+0,2	M4R+0,2
TOLERANCIA		TOL 4H	TOL 4H	TOL 6G	TOL 6G	TOL 7G	TOL 7G	TOL 6H (+0,1)	TOL 6H (+0,1)	TOL 6H (+0,2)	TOL 6H (+0,2)
MATERIAL		HSSCo 5%	HSSCo 5%	HSSCo 5%	HSSCo 5%	HSSCo 5%	HSSCo 5%	HSSCo 5%	HSSCo 5%	HSSCo 5%	HSSCo 5%
ACABADO		BRILLANTE	BRILLANTE	BRILLANTE	BRILLANTE	BRILLANTE	BRILLANTE	BRILLANTE	BRILLANTE	BRILLANTE	BRILLANTE
FORMA		FORMA B	FORMA B 35°	FORMA B	FORMA B 35°	FORMA B	FORMA B 35°	FORMA B	FORMA B 35°	FORMA B	FORMA B 35°
	$L_1 \times L_2 \times D_2 \times \square$ mm	€	€	€	€	€	€	€	€	€	€
M 3x0,50	2,50 R 56x11x 3,5x 2,7	19,61	24,26	14,39	17,12	19,61	24,26	20,24	27,01	23,23	28,76
M 4x0,70	3,30 R 63x13x 4,5x 3,4	20,07	24,26	14,39	17,12	20,07	24,26	20,73	27,01	23,76	28,76
M 5x0,80	4,20 R 70x16x 6,0x 4,9	20,07	23,24	14,39	16,80	20,07	23,24	20,73	25,87	23,76	27,54
M 6x1,00	5,00 R 80x17x 6,0x 4,9	22,06	25,50	15,49	18,45	22,06	25,50	22,75	28,39	26,12	30,23
M 8x1,00	7,00 D 90x20x 6,0x 4,9			30,17	33,37						
M 8x1,25	6,75 R 90x20x 8,0x 6,2	24,70	29,12	18,01	21,62	24,70	29,12	25,50	32,40	29,26	34,51
M 10x1,00	9,00 D 90x16x 7,0x 5,5			35,63	41,47						
M 10x1,50	8,50 R 100x22x10,0x 8,0	30,37	34,56	22,16	24,74	30,37	34,56	31,36	38,42	36,01	40,91
	MANGO DELGADO	M2D4H	M4D4H	M2D6G	M4D6G	M2D7G	M4D7G	M2D+0,1	M4D+0,1	M2D+0,2	M4D+0,2
M 12x1,50	10,50 D 100x22x 9,0x 7,0			64,92	76,97						
M 12x1,75	10,20 D 110x24x 9,0x 7,0	39,17	46,49	29,23	35,21	39,17	46,49	39,28	49,80	44,64	53,04
M 14x2,00	12,00 D 110x26x11,0x 9,0			35,91	43,14			64,08	79,29	72,83	84,43
M 16x2,00	14,00 D 110x27x12,0x 9,0			44,38	52,10			75,38	95,81	85,68	102,03
M 18x2,50	15,50 D 125x30x14,0x11,0			62,58	64,51			113,97	129,03	121,36	137,40
M 20x2,50	17,50 D 140x32x16,0x12,0			64,63	74,14			123,15	137,31	131,13	146,21

4H.- Para roscas muy precisas. Ajuste más exacto.

6G.- Para roscas con recubrimientos. Espesores entre 20 - 40 μ

7G.- Para roscas con recubrimientos. Espesores entre 40 - 50 μ

6H. (+0,1)- Hay que añadir 0,10mm a la broca previa.

6H. (+0,2)- Hay que añadir 0,20mm a la broca previa.

FORMA B **HSSCo 5%** **BRILLANTE** **TOL 6H** **R MANGO REFORZADO** **DIN 371** **D MANGO DELGADO** **DIN 376**

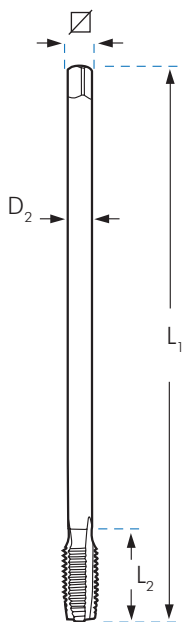

				M2L
			L ₁ x L ₂ x D ₂ x	FORMA B
				€
M	3x0,50	2,50	R 100 x 10 x 3,5 x 2,7	31,89
M	4x0,70	3,30	R 120 x 12 x 4,5 x 3,4	32,59
M	5x0,80	4,20	R 140 x 14 x 6,0 x 4,9	32,59
M	6x1,00	5,00	R 160 x 16 x 6,0 x 4,9	35,82
M	7x1,00	6,00	R 160 x 17 x 7,0 x 5,5	39,90
M	8x1,25	6,80	R 180 x 18 x 8,0 x 6,2	41,99
MANGO DELGADO				M2L-D
M	6x1,00	5,00	D 160 x 16 x 4,5 x 3,4	36,48
M	8x1,25	6,80	D 180 x 18 x 6,2 x 5,0	42,79
M	10x1,50	8,50	D 200 x 20 x 7,0 x 5,5	51,69
M	12x1,75	10,20	D 220 x 22 x 8,5 x 6,5	63,60
M	14x2,00	12,00	D 220 x 25 x 10,5 x 8,0	96,82
M	16x2,00	14,00	D 220 x 28 x 12,5 x 10,0	113,89
M	18x2,50	15,50	D 250 x 32 x 14,0 x 11,0	207,23
M	20x2,50	17,50	D 250 x 32 x 16,0 x 12,0	223,99

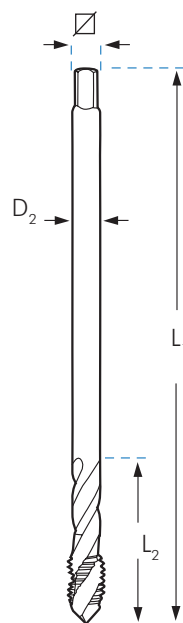

				M4L
			L ₁ x L ₂ x D ₂ x	
				€
M	3x0,50	2,50	R 100 x 10 x 3,5 x 2,7	39,46
M	4x0,70	3,30	R 120 x 12 x 4,5 x 3,4	39,46
M	5x0,80	4,20	R 140 x 14 x 6,0 x 4,9	37,80
M	6x1,00	5,00	R 160 x 16 x 6,0 x 4,9	41,48
M	7x1,00	6,00	R 160 x 17 x 7,0 x 5,5	46,18
M	8x1,25	6,80	R 180 x 18 x 8,0 x 6,2	50,39
MANGO DELGADO				M4L-D
M	6x1,00	5,00	D 160 x 16 x 4,5 x 3,4	42,26
M	8x1,25	6,80	D 180 x 18 x 6,2 x 5,0	49,44
M	10x1,50	8,50	D 200 x 20 x 7,0 x 5,5	58,40
M	12x1,75	10,20	D 220 x 22 x 8,5 x 6,5	75,55
M	14x2,00	12,00	D 220 x 25 x 10,5 x 8,0	108,49
M	16x2,00	14,00	D 220 x 28 x 12,5 x 10,0	157,23
M	18x2,50	15,50	D 250 x 32 x 14,0 x 11,0	234,65
M	20x2,50	17,50	D 250 x 32 x 16,0 x 12,0	249,73



HSSCo
5%

BRILLANTE

TOL
6H

DIN
357

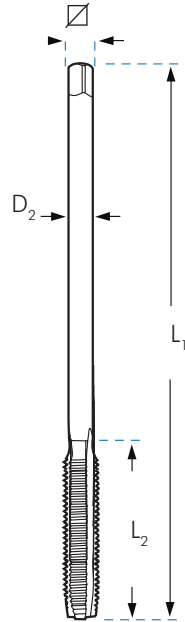

				MTU	
				FORMA A	€
			$L_1 \times L_2 \times D_2 \times \square$ mm		
M	3x0,50*	2,50	D 70 x 22 x 2,2		21,47
M	4x0,70	3,30	D 90 x 25 x 2,8 x 2,1		21,47
M	5x0,80	4,20	D 100 x 28 x 3,5 x 2,7		21,47
M	6x1,00	5,00	D 110 x 32 x 4,5 x 3,4		21,47
M	8x1,25	6,80	D 125 x 40 x 6,0 x 4,9		25,89
M	10x1,50	8,50	D 140 x 45 x 7,0 x 5,5		25,30
M	12x1,75	10,20	D 180 x 50 x 9,0 x 7,0		30,65
M	14x2,00	12,00	D 200 x 56 x 11,0 x 9,0		48,42
M	16x2,00	14,00	D 200 x 63 x 12,0 x 9,0		59,95
M	18x2,50	15,50	D 220 x 63 x 14,0 x 11,0		80,66
M	20x2,50	17,50	D 250 x 70 x 16,0 x 12,0		113,86
M	22x2,50	19,50	D 280 x 80 x 18,0 x 14,5		139,70
M	24x3,00	21,00	D 280 x 80 x 18,0 x 14,5		190,07

* Mango cilíndrico

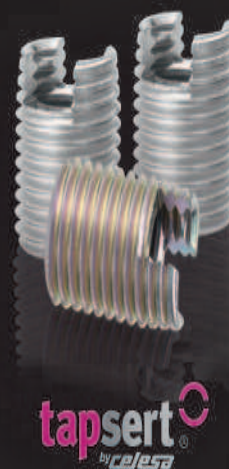

INSERTOS
LIBRES

INSERTOS SÓLIDOS
CON SELLADOR ANAERÓBICO

INSERTOS
AUTORROSCANTES

CASQUILLOS ROSCADOS
DE SEGURIDAD

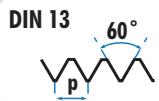

HSSCo
5%

BRILLANTE

TOL
6H

R
MANGO
REFORZADO

DIN
371

D
MANGO
DELGADO

DIN
376

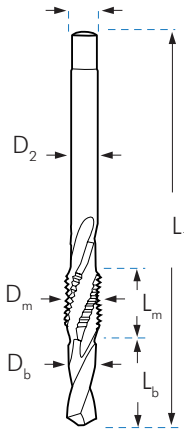

		L _b mm	L _m mm	L ₁ mm	D _b mm	D _m mm	D ₂ mm	∅ mm	M8M €
M 3x0,50	R	9,0	12,5	62,0	2,50	3,0	3,5	2,7	32,31
M 4x0,70	R	10,0	16,0	66,0	3,30	4,0	4,5	3,4	32,31
M 5x0,80	R	12,5	18,0	75,5	4,20	5,0	6,0	4,9	33,58
M 6x1,00	R	14,0	20,0	81,0	5,00	6,0	6,0	4,9	37,09
M 8x1,00	R	20,0	14,0	91,0	7,00	8,0	6,0	4,9	43,52
M 8x1,25	R	20,0	14,0	91,0	6,75	8,0	8,0	6,2	45,15

MANGO DELGADO

M 8x1,25	D	20,0	14,0	91,0	6,75	8,0	6,0	4,9	45,15
M 10x1,00	D	20,0	15,0	95,0	9,00	10,0	7,0	5,5	54,03
M 10x1,50	D	25,0	18,0	105,0	8,50	10,0	7,0	5,5	57,34
M 12x1,50	D	24,0	18,0	110,0	10,50	12,0	9,0	7,0	62,59
M 12x1,75	D	28,0	20,0	118,0	10,20	12,0	9,0	7,0	62,22
M 14x1,50	D	28,0	20,0	118,0	12,50	14,0	11,0	9,0	99,04
M 14x2,00	D	28,0	22,0	130,0	12,00	14,0	11,0	9,0	112,65
M 18x2,50	D	40,0	26,0	151,0	15,50	18,0	14,0	11,0	216,09
M 20x2,50	D	45,0	30,0	168,0	17,50	20,0	16,0	12,0	310,32

Nota: Jamás emplee los Broca-Machos en agujeros ciegos o en pasantes más profundos que L_b

MACHO DE MÁQUINA ROSCA TRAPEZOIDAL HSS

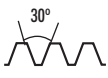

HSS

BRILLANTE



DIN
103

TOL
7H

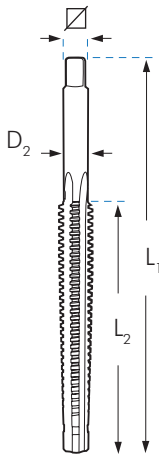

			L ₁ x L ₂ x D ₂ x ∅ mm	MRTM €
Tr 14 x 3	11,25	160	105 x 10,5 x 8,0	507,68
Tr 16 x 4	12,25	205	110 x 11,5 x 9,0	528,52
Tr 18 x 4	14,25	215	120 x 13,0 x 10,0	557,14
Tr 20 x 4	16,25	230	130 x 15,0 x 12,0	559,75
Tr 22 x 5	17,25	270	165 x 16,0 x 12,0	736,79
Tr 24 x 5	19,25	280	165 x 18,0 x 14,5	835,73
Tr 26 x 5	21,25	290	170 x 20,0 x 16,0	864,72
Tr 28 x 5	23,25	300	180 x 22,0 x 18,0	979,54
Tr 30 x 6	24,25	345	200 x 23,0 x 18,0	1.127,31

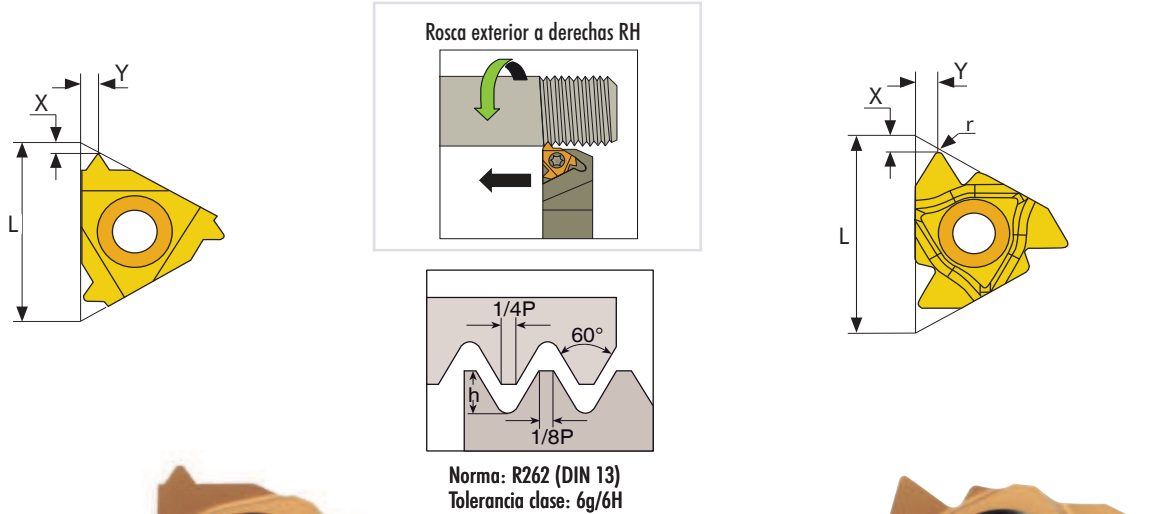

Perfil Total

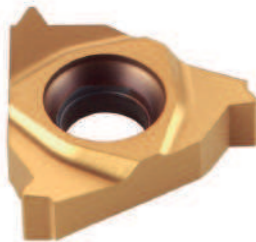
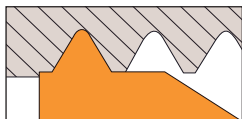

Perfil Parcial

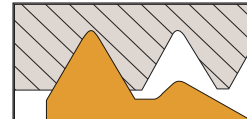

Rosca el perfil completo, terminando el diámetro exterior de la rosca. Utilizaremos una plaquita diferente para cada paso.

No termina el diámetro exterior de la rosca. La misma plaquita puede ser utilizada para una gama de diferentes pasos, que tengan el mismo ángulo de rosca.

PERFIL TOTAL 60°

ROSCADO EXTERIOR	L	PASO	h	X	Y	€
PRE-16-075	16	0,75	0,46	0,6	0,6	22,74
PRE-16-100		1,00	0,61	0,7	0,7	22,74
PRE-16-125		1,25	0,77	0,8	0,9	22,74
PRE-16-150		1,50	0,92	0,8	1	22,74
PRE-16-175		1,75	1,07	0,9	1,2	22,74
PRE-16-200		2,00	1,23	1	1,3	22,74
PRE-16-250		2,50	1,53	1,1	1,5	22,74
PRE-16-300		3,00	1,84	1,2	1,6	22,74

PERFIL PARCIAL 60°

ROSCADO EXTERIOR	L	RANGOS MÉTRICOS	RANGO PULGADAS	r	X	Y	€
PPRE-16-150	16	0,50-1,50	48 - 16	0,05	0,80	0,90	22,74
PPRE-16-300		1,75-3,00	14 - 8	0,27	1,20	1,70	22,74

PORTAHERRAMIENTAS DE ROSCADO DE EXTERIORES

ROSCADO EXTERIOR	H1=H=B=F	L1	L2	€
PEXT-20-16	20	128	30	145,68
PEXT-25-16	25	153	30	166,31

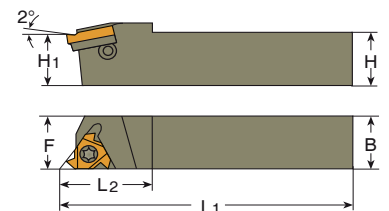
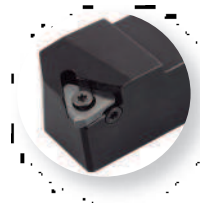

	Vc		Vc
ACERO BLANDO 70 kg/mm ² BC2	25 m/min	ALUMINIO BC16	50 m/min
ACERO TRATADO 120 kg/mm ² BC5	13 m/min	TITANIO BC42	18 m/min
INOXIDABLE BC50	11 m/min	FUNDICIÓN BC7	25 m/min
		LATÓN BC66	50 m/min

FÓRMULA MATEMÁTICA PARA OBTENER LA VELOCIDAD DE GIRO DE LA PIEZA (RPM)

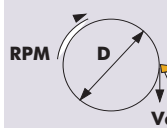

$$RPM = \frac{1000 \times Vc}{\pi \times D}$$

RPM: Revoluciones x minuto
Vc: Velocidad de Corte (m/min)
D: Diámetro Pieza (mm)

Las RPM-s se Obtienen en función de Vc y D

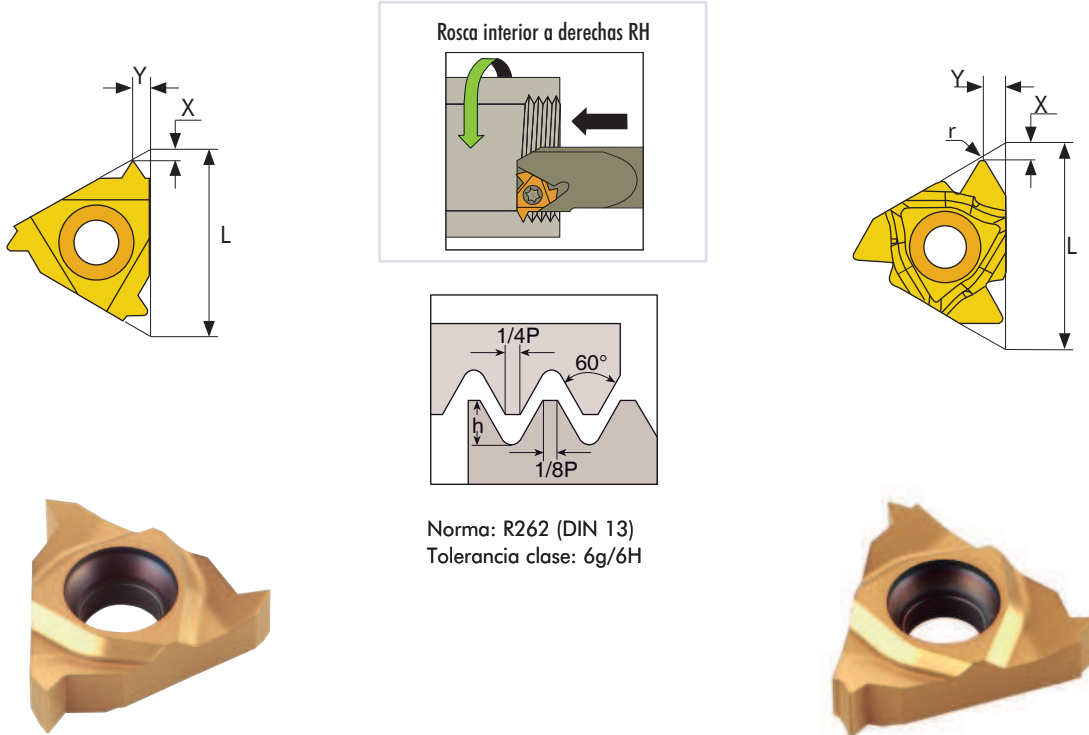

PERFIL TOTAL 60°

ROSCADO INTERIOR	L	PASO	h	X	Y	€
PRI-16-075	16	0,75	0,43	0,6	0,6	22,74
PRI-16-100		1,00	0,58	0,6	0,7	22,74
PRI-16-125		1,25	0,72	0,8	0,9	22,74
PRI-16-150		1,50	0,87	0,8	1,0	22,74
PRI-16-175		1,75	1,01	0,9	1,2	22,74
PRI-16-200		2,00	1,15	1,0	1,3	22,74
PRI-16-250		2,50	1,44	1,1	1,5	22,74
PRI-16-300		3,00	1,73	1,1	1,5	22,74

PERFIL PARCIAL 60°

ROSCADO INTERIOR	L	RANGOS MÉTRICOS	RANGO PULGADAS	r	X	Y	€
PPRI-16-150	16	0,50-1,50	48 - 16	0,05	0,80	0,90	22,74
PPRI-16-300		1,75-3,00	14 - 8	0,16	1,20	1,70	22,74

PORTAHERRAMIENTAS DE ROSCADO DE INTERIORES

ROSCADO INTERIOR	L	L1	D	D1	A	Ø Mín. agujero	€
PINT-20-16	180	40	20	20	18	24	163,92
PINT-25-16	200	45	25	24,6	22,6	29	200,42

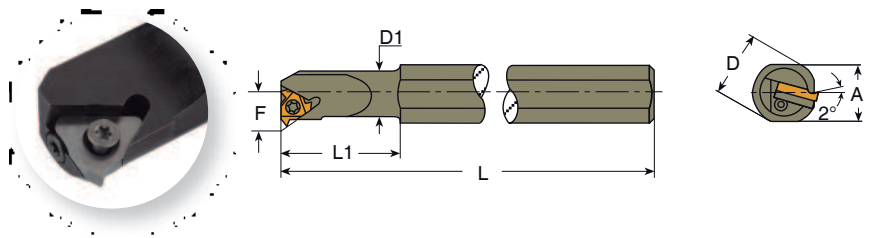

**USO
GENERAL**

**HSSCo
5%**



Ref. JM6



Ref. JM2





Ref. JM8



Ref. JM4



CONTENIDO

	FORMA C	FORMA B	 15°	 35°	 HSS	HSS Co 5% €
JM5	M3 - M4 - M5 - M6 M8 - M10 - M12	-	-	-	-	92,17
JM1	M3 - M4 - M5 - M6 M8 - M10 - M12	-	-	-	2.5 / 3.3 / 4.2 / 5.0 6.8 / 8.5 / 10.2 mm	110,24
JM6	-	M3 - M4 - M5 - M6 M8 - M10 - M12	-	-	-	98,20
JM2	-	M3 - M4 - M5 - M6 M8 - M10 - M12	-	-	2.5 / 3.3 / 4.2 / 5.0 6.8 / 8.5 / 10.2 mm	110,44
JM7	-	-	M3 - M4 - M5 - M6 M8 - M10 - M12	-	-	122,34
JM3	-	-	M3 - M4 - M5 - M6 M8 - M10 - M12	-	2.5 / 3.3 / 4.2 / 5.0 6.8 / 8.5 / 10.2 mm	146,18
JM8	-	-	-	M3 - M4 - M5 - M6 M8 - M10 - M12	-	124,45
JM4	-	-	-	M3 - M4 - M5 - M6 M8 - M10 - M12	2.5 / 3.3 / 4.2 / 5.0 6.8 / 8.5 / 10.2 mm	144,62





Ref. JMPT2

CONTENIDO

	FORMA B	BRILLANTE	 35°	BRILLANTE	 HSSCo 5%	HSS PM €		TiN €
JMP6	M3 - M4 - M5 - M6 M8 - M10 - M12		-		-	102,33	JMPT6	147,59
JMP2	M3 - M4 - M5 - M6 M8 - M10 - M12		-		2.5 / 3.3 / 4.2 / 5.0 6.8 / 8.5 / 10.2 mm	134,19	JMPT2	179,58
JMP8	-		M3 - M4 - M5 - M6 M8 - M10 - M12		-	147,59	JMPT8	162,55
JMP4	-		M3 - M4 - M5 - M6 M8 - M10 - M12		2.5 / 3.3 / 4.2 / 5.0 6.8 / 8.5 / 10.2 mm	179,58	JMPT4	194,64



INOX

CONTENIDO

	FORMA B	OX	 35°	OX	 HSSCo 5%	HSS PM €		TiN €
JMX6	M3 - M4 - M5 - M6 M8 - M10 - M12		-		-	132,02	JMXT6	144,01
JMX2	M3 - M4 - M5 - M6 M8 - M10 - M12		-		2.5 / 3.3 / 4.2 / 5.0 6.8 / 8.5 / 10.2 mm	164,01	JMXT2	176,01
JMX8	-		M3 - M4 - M5 - M6 M8 - M10 - M12		-	150,66	JMXT8	166,09
JMX4	-		M3 - M4 - M5 - M6 M8 - M10 - M12		2.5 / 3.3 / 4.2 / 5.0 6.8 / 8.5 / 10.2 mm	182,64	JMXT4	198,07



CONTENIDO

	FORMA B	OX	 35°	OX	 HSSCo 5%	HSS V3 €		TINALOX €
JMMD6	M3 - M4 - M5 - M6 M8 - M10 - M12		-		-	120,00	JMMDT6	170,37
JMMD2	M3 - M4 - M5 - M6 M8 - M10 - M12		-		2.5 / 3.3 / 4.2 / 5.0 6.8 / 8.5 / 10.2 mm	151,99	JMMDT2	202,35
JMMD8	-		M3 - M4 - M5 - M6 M8 - M10 - M12		-	136,95	JMMDT8	196,45
JMMD4	-		M3 - M4 - M5 - M6 M8 - M10 - M12		2.5 / 3.3 / 4.2 / 5.0 6.8 / 8.5 / 10.2 mm	168,94	JMMDT4	228,43



Ref. JMC2

CONTENIDO

	FORMA B	TiCN	15°	TiCN	HSSCo 5%	HSS-PM €
JMC6	M3 - M4 - M5 - M6 M8 - M10 - M12		-		-	204,14
JMC2	M3 - M4 - M5 - M6 M8 - M10 - M12		-		2.5 / 3.3 / 4.2 / 5.0 6.8 / 8.5 / 10.2 mm	236,13
JMC8	-		M3 - M4 - M5 - M6 M8 - M10 - M12		-	232,36
JMC4	-		M3 - M4 - M5 - M6 M8 - M10 - M12		2.5 / 3.3 / 4.2 / 5.0 6.8 / 8.5 / 10.2 mm	264,35

TODO TERRENO

CONTENIDO

	FORMA B	TiN	35°	TiN	HSSCo 5%	HSS Co 5% €
JMD6	M3 - M4 - M5 - M6 M8 - M10 - M12		-		-	184,48
JMD2	M3 - M4 - M5 - M6 M8 - M10 - M12		-		2.5 / 3.3 / 4.2 / 5.0 6.8 / 8.5 / 10.2 mm	216,46
JMD8	-		M3 - M4 - M5 - M6 M8 - M10 - M12		-	208,03
JMD4	-		M3 - M4 - M5 - M6 M8 - M10 - M12		2.5 / 3.3 / 4.2 / 5.0 6.8 / 8.5 / 10.2 mm	240,02

AI

CONTENIDO

	DIENTE ALTERNO	BRILLANTE	2 CANALES	BRILLANTE	HSS	HSS Co 5% €
JMAL6	M3 - M4 - M5 - M6 M8 - M10 - M12		-		-	146,06
JMAL2	M3 - M4 - M5 - M6 M8 - M10 - M12		-		2.5 / 3.3 / 4.2 / 5.0 6.8 / 8.5 / 10.2 mm	178,05
JMAL8	-		M3 - M4 - M5 - M6 M8 - M10 - M12		-	144,43
JMAL4	-		M3 - M4 - M5 - M6 M8 - M10 - M12		2.5 / 3.3 / 4.2 / 5.0 6.8 / 8.5 / 10.2 mm	176,42

**USO
GENERAL**

CONTENIDO

	FORMA B	BRILLANTE	35°	BRILLANTE	HSS Co 5% €
PT01	M4 - M5 - M6 M8 - M10		M4 - M5 - M6 M8 - M10		112,03



Ref. PT01

Plus

CONTENIDO

	FORMA B	BRILLANTE	35°	BRILLANTE	HSS PM €	TiN €
PT02	M4 - M5 - M6 M8 - M10		M4 - M5 - M6 M8 - M10		140,93	PT03 206,96



Ref. PT03

INOX

CONTENIDO

	FORMA B	OX	35°	OX	HSS PM €	TiN €
PT05	M4 - M5 - M6 M8 - M10		M4 - M5 - M6 M8 - M10		185,17	PT13 197,06



Ref. PT05



CONTENIDO

	FORMA B	OX	35°	OX	HSS V3 €	TINALOX €
PT04	M4 - M5 - M6 M8 - M10		M4 - M5 - M6 M8 - M10		158,92	PT14 238,82



Ref. PT04



CONTENIDO

	FORMA B	TiCN	15°	TiCN	HSS PM €
PT11	M4 - M5 - M6 M8 - M10		M4 - M5 - M6 M8 - M10		287,90



Ref. PT11

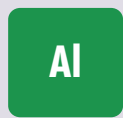

Ref. PT06

CONTENIDO

	DIENTE ALTERNO	2 CANALES	HSS Co 5% €
PT06	M4 - M5 - M6 M8 - M10	M4 - M5 - M6 M8 - M10	175,69



Ref. PT07

CONTENIDO

	FORMA C	HSS Co 5% €
PT07	M4 - M5 - M6 - M8 - M10 M4 - M5 - M6 - M8 - M10	132,78



Ref. PT10

CONTENIDO

	FORMA C	HSS Co 5% €
PT10	M4 - M5 - M6 - M8 - M10 M4 - M5 - M6 - M8 - M10	161,40



Ref. PT08

CONTENIDO

	Laminación	HSS Co 5% €
PT08	M4 - M5 - M6 - M8 - M10 M4 - M5 - M6 - M8 - M10	243,01



Ref. PT09

CONTENIDO

		HSS Co 5% €
PT09	M4 - M5 - M6 - M8 - M10 M4 - M5 - M6 - M8 - M10	327,38



Ref. PT12

CONTENIDO

	FORMA B	35°	HSS Co 5% €
PT12	M4 - M5 - M6 M8 - M10	M4 - M5 - M6 M8 - M10	181,54

EXPOSITOR DE METACRILATO

MM-03

Composición: Machos de máquina, Serie Normal

HSSCo
5%

FORMA
B

Agujeros pasantes, Ref. M2

M4	M5	M6	M8	M10	M12	M14
5	10	10	10	10	5	4

35°

Agujeros ciegos, Ref. M4

M4	M5	M6	M8	M10	M12	M14
5	10	10	10	10	5	4

Dimensiones: ancho 240 x fondo 240 x alto 245 mm

1.522,29 €



Ref. MM-03



Ref. MM-04

EXPOSITOR DE METACRILATO

MM-04

Composición: Machos de máquina, Serie Plus
Fabricados en Acero sinterizado PM

HSS
PM

Plus

FORMA
B

Agujeros pasantes, Ref. M2

M4	M5	M6	M8	M10	M12	M14
5	10	10	10	10	5	4

35°

Agujeros ciegos, Ref. M4

M4	M5	M6	M8	M10	M12	M14
5	10	10	10	10	5	4

Dimensiones: ancho 240 x fondo 240 x alto 245 mm

2.077,06 €

EXPOSITOR DE METACRILATO

MM-05

Composición: Machos de máquina para trabajos especiales

FORMA
B

Agujeros pasantes, Ref. M2

1200
N/mm²

M4	M5	M6	M8	M10	M12	M14
1	2	2	2	2	1	1

INOX

M4	M5	M6	M8	M10	M12	M14
1	2	2	2	2	1	1

Al

M4	M5	M6	M8	M10	M12	M14
1	2	2	2	2	1	1

TiN

M4	M5	M6	M8	M10	M12	M14
1	2	2	2	2	1	1

1400
N/mm²

M4	M5	M6	M8	M10	M12
1	2	2	2	2	1

35°

Agujeros ciegos, Ref. M4

1200
N/mm²

M4	M5	M6	M8	M10	M12	M14
1	2	2	2	2	1	1

INOX

M4	M5	M6	M8	M10	M12	M14
1	2	2	2	2	1	1

Al

M4	M5	M6	M8	M10	M12	M14
1	2	2	2	2	1	1

TiN

M4	M5	M6	M8	M10	M12	M14
1	2	2	2	2	1	1

1400
N/mm²

M4	M5	M6	M8	M10	M12
1	2	2	2	2	1

2.495,93 €