

ARTICULO: 2833

Junta de expansión de EPDM extremos Bridados. Doble onda Rubber Expansion Joint, Flanged ends. Double Spherical

Características

1. Junta de expansión. Doble Onda.
2. Reducción de Ruidos.
3. Absorción de Vibraciones.
4. Compensación de dilataciones.
5. Facil instalación.
6. Cuerpo de EPDM, Extremos acero carbono.
7. Extremos para montar entre bridas EN 1092:
PN10/16 (medidas 2" a 6")
PN10 (medidas 8" a 12")
8. Presión de trabajo máxima:
16 bar (medidas 2" a 6")
10 bar (medidas 8" a 12")
9. Depresión máxima (vacío) 400 mbar.
10. Temperatura de Trabajo – 10 °C + 105 °C.
11. Presión de Ruptura 48 bar.

Features

1. *Expansion Joint. Double Spherical.*
2. *Reduction of Noise.*
3. *Absortion of vibration.*
4. *Allows axial and lateral movement.*
5. *Easy to install.*
6. *Body made of EPDM, Ends of carbon steel..*
7. *Ends connecting with flanges EN 1092:*
PN10/16 (sizes 2" to 6")
PN10 (sizes 8" to 12")
8. *Max. Working pressure:*
16 bar (sizes 2" to 6")
10 bar (sizes 8" to 12")
9. *Max. Working Vacuum 400 mbar.*
10. *Working temperature – 10 °C + 105 °C.*
11. *Burst Pressure 48 bar.*

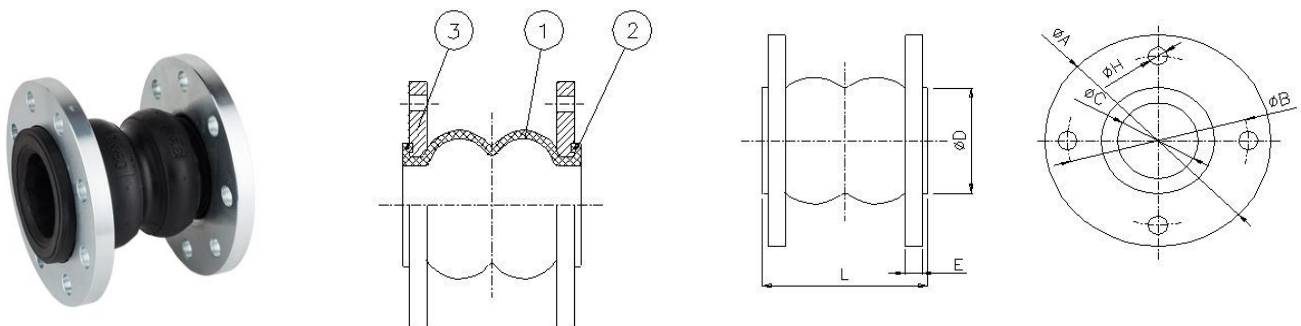

Nº	Denominación / Name	Material	Acabado Superficial / Surface Treatment
1	Cuerpo / Body	EPDM + Nylon	-----
2	Aro / Ring	Acero Carbono / Carbon steel	Cincado / Zinc plated
3	Brida / Flange	Acero Carbono / Carbon steel	Cincado / Zinc plated

DIMENSIONES GENERALES / GENERAL DIMENSIONS

Ref	Medida / Size	DN	PN	Dimensiones / Dimensions (mm)							Peso / Weight (Kg)
				ØA	ØB	ØC	ØD	n x ØH	L	E	
2833 09	2"	50	16	165	125	52	86	4 x 18	175	16	4.40
2833 10	2 1/2"	65	16	185	145	68	106	4 x 18	175	16	5.20
2833 11	3"	80	16	200	160	76	116	8 x 18	175	18	6.30
2833 12	4"	100	16	220	180	103	150	8 x 18	225	18	7.30
2833 13	5"	125	16	250	210	128	180	8 x 18	225	20	10.20
2833 14	6"	150	16	285	240	152	209	8 x 22	225	22	13.40
2833 16	8"	200	10	340	295	194	260	8 x 22	325	22	18.90
2833 18	10"	250	10	395	350	250	320	12 x 22	325	24	23.20
2833 20	12"	300	10	445	400	300	367	12 x 22	325	24	28.60

Diagrama de desplazamientos / Diagram of displacements

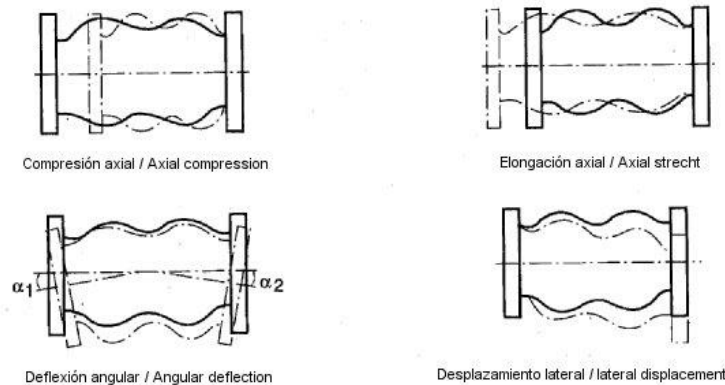

Ref.	Compresión Axial Axial Compression (mm)	Elongación Axial Axial Stretch (mm)	Deflexión Angular Angular deflection ($\alpha_1 + \alpha_2$)	Desplazamiento lateral Lateral Displacement (mm)
2833 09	30	20	30°	45
2833 10	50	25	30°	45
2833 11	50	25	30°	45
2833 12	50	35	30°	35
2833 13	50	35	30°	35
2833 14	50	35	30°	35
2833 16	50	35	30°	30
2833 18	50	35	15°	30
2833 20	50	35	15°	30

CURVA PRESIÓN TEMPERATURA / *PRESSURE TEMPERATURE RATING*

