

ACTUADORES NEUMÁTICOS
PNEUMATIC ACTUATORS
PNEUMATISCHE SCHWENKANTRIEBE
ACTIONNEURS PNEUMATIQUES

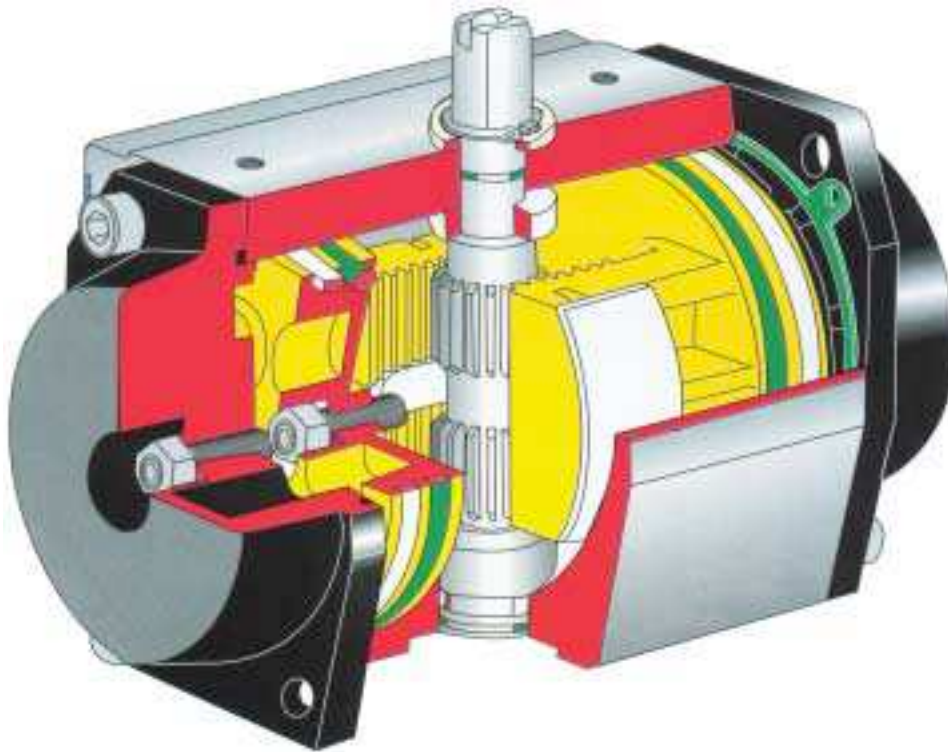



**PROTECCIONES DISPONIBLES – AVAILABLE PROTECTIONS
VERFUGBARE SCHUTZBESCHICHTUNGEN – PROTECTIONS DISPONIBLES**

SERIE “ AE ”

Cuerpo:	Anodizado duro	Body:	Hard anodized
Capas:	Epoxy Poliéster	End caps:	Epoxy Poliester
Eje:	Níquel químico	Shaft:	ENP
Gehäuse:	Hardanodisiert	Corps:	Anodise dur
Deckel:	Epoxy Polyester	Couvercles:	Epoxy Polyester
Welle:	Chemisch Vernickel	Axe:	Nickel Chimie

SERIE “ NN ”

Cuerpo:	Níquel químico	Body:	ENP
Tapas:	Níquel químico	End caps:	ENP
Eje:	Níquel químico	Shaft:	ENP
Gehäuse:	Chemisch vernickel	Corps:	Nickel Chimie
Deckel:	Chemisch vernickel	Couvercles:	Nickel Chimie
Welle:	Chemisch vernickel	Axe:	Nickel Chimie

Modelo - Model Model - Modèle	Presión Máx. Max. Pressure Maximaldruck Pression Max	Rotación Rotation Rotationen Rotation	Volumen- Volumen Volumen - Volume	Abierto - Open Offen - Ouvert		Cerrado - Closed Geschlossen - Ferme		Grasa Estándard Standard Grease Standard Fett Graisse Standard
				DA	SR	DA	SR	
CH032	8 bar	90° +/- 3	0,07 Litres	0,5 sec.	-	0,5 sec.	-	Bisulfuro de Molibdeno - Molydenum Bisulp.
CH042			0,18 Litres		0,5 sec.		0,5 sec.	
CH050			0,23 Litres	0,6 sec.	0,6 sec.	0,6 sec.		
CH063			0,45 Litres		0,7 sec.	0,7 sec.	0,9 sec.	
CH075			0,61 Litres			1,0 sec.	1,0 sec.	
CH085			0,98 Litres		0,9 sec.	1,3 sec.		
CH100		1,80 Litres	90° +/- 5	0,8 sec.	1,1 sec.	0,9 sec.	1,3 sec.	
CH115		2,80 Litres		1,2 sec.	1,1 sec.	1,6 sec.		
CH125		3,70 Litres		1,3 sec.	2,1 sec.	2,1 sec.		
CH145		4,90 Litres		1,1 sec.	1,4 sec.	2,0 sec.		
CH160		8,00 Litres		1,3 sec.	2,1 sec.	2,6 sec.		
CH180		11,10 Litres		2,3 sec.	2,6 sec.	2,6 sec.		
CH200		14,20 Litres		3,6 sec.	4,6 sec.	6,1 sec.		
CH240		19,20 Litres		4,1 sec.	4,5 sec.	4,5 sec.		
CH270		22,20 Litres		4,5 sec.	6,0 sec.	4,5 sec.	6,0 sec.	

CARACTERÍSTICAS GENERALES

- Alimentación: Aire comprimido filtrado, seco o lubricado, presión mínima 1 bar, presión máxima 10 bar.
- Lubricación realizada en fábrica y garantizada para un mínimo de 1.000.000 de maniobras.
- Acabado de la superficie interior del cuerpo (Ra 0,4-0,6 um) para reducir al mínimo la fricción y maximizar la vida del actuador.
- Patines deslizantes en material de bajo coeficiente de fricción (LAT LUB) para evitar el contacto metal-metal, fácilmente reemplazables para su mantenimiento.
- Doble taladrado inferior para el anclaje y centrado de la válvula según norma ISO 5211 y DIN 3337.
- Conexión inferior eje cuadrado hembra según norma ISO 5211/ DIN 333 para montaje a 45° o 90° indistintamente.
- Montaje directo electroválvula según norma NAMUR.
- Montaje accesorios según norma NAMUR VDI/ VDE 3845.
- Temperatura de trabajo: de -20°C a +80°C.
- Protección externa cuerpo: Anodizado Duro. 500 horas Cámara Niebla salina según ASTM B117-73.
- Protección externa tapas: Recubrimiento Epoxy-Poliéster.
- Limitador de carrera a la apertura y al cierre.
- Control de funcionamiento y estanquidad 100% a través de sistema electrónico con certificación individual.

MATERIALES UTILIZADOS

- Cuerpo:** Aleación de aluminio extruido según ASTM 6063. Anodizado duro según UNI 4522. Opcional recubrimiento níquel químico.
- Tapas:** Aleación de aluminio inyectado ASTM B179 protegido con Epoxy-Poliéster. Opcional recubrimiento níquel químico.
- Pistones:** Aleación de aluminio inyectado ASTM B179.
- Piñón:** Acero carbono + níquel químico.
- Patines:** Resina acetálica (LAT LUB 731320T).
- Tornillos:** Acero inox. AISI 304.
- Muelles:** Cartuchos precomprimidos acero recubierto resina epoxídica.
- Juntas estanquidad:** NBR (VITON bajo pedido).
- Grasa estándar:** MoS₂.

ALLGEMEINE EIGENSCHAFTEN

- Speisung: trockene oder geschmierte filtrierte Druckluft Minimaldruck 1 Bar, Maximaldruck 10 Bar.
- In der Werkstatt durchgeführte Schmierung, die garantiert für mindestens 1000000 Arbeitsvorgänge ausreicht.
- Feinbearbeitung der internen Oberfläche (Ra 0.4-0.6 mm), um die Reibung zu minimieren und die Lebensdauer des Aktuators selbst zu maximieren.
- Führungen aus Material mit niedrigem Reibungskoeffizient (LAT LUB), um den Kontakt von Metall auf Metall zu vermeiden; leicht auswechselbar bei Wartung.
- Doppelte, untere Bohrung zur Fixierung des Ventils und Zentrierung entsprechend den Normen ISO 5211/ DIN 3337.
- Unterer, weiblicher Schlüssel des Ritzels, den Normen ISO 5211/ DIN 3337 entsprechend, zur Montage auf Ventile mit einer Welle mit Vierkantschlüssel auf gleicher Linie.
- Bohrung der Speiseanschlußstücke nach NAMUR-Normen.
- Obere Bohrung, zur Fixierung von Zubehör, und oberes Ritzelende nach NAMUR-Normen.
- Standardausführung für Temperaturen von -20°C bis +80°C.
- Äußere Schutzbeschichtung: Korrosionswiderstand von 500 Stunden in Salznebel, nach ASTM B117-73.
- Automatisch gepunzter Etikettenaufkleber mit fortlaufender Seriennummer.
- Funktions- und Dichtheitsprüfung auf 100% mit elektronischer Apparatur und Einzelbeurkundung des Produkts.

VERWENDETE MATERIALIEN

- Körper:** Aluminiumlegierung, fließgepreßt nach ASTM 6063, eloxiert nach UNI 4522, oder vernickelt (chem. Nickel), oder durch Epoxydharzlackierung geschützt.
- Zylinderköpfe:** Druckguß aus Aluminiumlegierung nach ASTM B179, mit Epoxydpolyesterstaub lackiert oder chem. Nickel.
- Kolben:** druckgegossen aus Aluminiumlegierung nach ASTM B179.
- Ritzel:** aus vernickeltem Stahl.
- Führungen:** aus Azetalharz (LAT LUB 731320T).
- Schrauben:** aus INOX-Stahl nach AISI 304.
- Federn:** Vorspannung durch Einsatz gegeben, mit Epoxydpulver lackiert.
- Dichtungen:** aus Nitrilgummi NBR (auf Wunsch VITON oder EPDM).
- Standard fett:** MoS₂.

GENERAL FEATURES

- Supply: dry or lubricated filtered compressed air; pressure: min. 1 Bar, max. 10 Bar.
- The lubrication carried out by the manufacturer is guaranteed for min. 1000000 manoeuvres.
- Inside surface finish (Ra 0.4-0.6 mm) to minimize friction and to maximize the life of the actuator.
- Slideways made of material with a low friction coefficient (LAT LUB) to avoid metal to metal contact, easily replaceable for maintenance.
- Double lower drilling, for fastening the valve, and centering, according to ISO 5211/ DIN 3337 standards.
- Lower female pinion key, according to ISO 5211/ DIN 3337 standards, for assembly on valves with square key on line shaft.
- Drilling of the supplying connections according to NAMUR standards.
- Upper drilling for fastening the accessories, and upper pinion end according to NAMUR standards.
- Standard execution for temperatures from -20°C to +80°C.
- External protection: resistance to corrosion of 500 hrs in salty fog according to ASTM B117-73.
- Adhesive labels on which the progressive serial number is automatically punched.
- Running test and 100% seal test carried out with electronic equipment and certification of each individual product.

MATERIALS USED

- Body:** Aluminium alloy, extruded according to ASTM 6063, anodized according to UNI 4522, nickel-plated (chemical nickel) or protected with epoxy-paint.
- Heads:** die-cast in aluminium alloy ASTM B179, painted with epoxy-polyester powder or chemical Nickel.
- Pistons:** die-cast in aluminium alloy ASTM B179.
- Pinion:** nickel-plated steel.
- Slideways:** acetal resin (LAT LUB 731320T).
- Screws:** stainless steel AISI 304.
- Springs:** precompressed cartridge, painted with epoxy powder.
- Seals:** nitrile rubber NBR (VITON or EPDM on request).
- Standard grease:** MoS₂.

CARACTÉRISTIQUES GÉNÉRALES

- Alimentation: air comprimé filtré, sec ou lubrifié, pression min. 1 Bar, max. 10 Bar.
- Lubrification: faite à l'usine et garantie pour min. 1000000 de manoeuvres.
- Finissage de la surface intérieure (Ra 0.4-0.6 mm) pour réduire au minimum les frottements et prolonger au maximum la vie de l'actionneur.
- Glissières en matériel à bas coefficient de frottement (LAT LUB), pour éviter le contact métal contre métal, peuvent être facilement remplacées pour l'entretien.
- Double perçage inférieur pour le fixation de la valve, et le centrage, suivant les normes ISO 5211/ DIN 3337.
- Clé femelle inférieure du pignon, suivant les normes ISO 5211/ DIN 3337, pour montage sur des valves avec arbre à clé carrée en ligne.
- Perçage des raccords d'alimentation suivant les normes NAMUR.
- Perçage supérieur, pour le fixation des accessoires, et bout supérieure du pignon suivant les normes NAMUR.
- Exécution standard pour températures de -20°C bis +80°C.
- Protection extérieure: résistance à la corrosion: 500 heures dans un brouillard salin suivant ASTM B117-73.
- Etiquette adhésive avec numéro de série progressif poëçonné automatiquement.
- Contrôle de fonctionnement et de 100% des étanchéités effectué avec un appareillage électronique et certification de chaque produit.

MATÉRIELS UTILISÉS

- Corps:** en alliage d'aluminium extrudé ASTM 6063, anodisé UNI 4522, ou nickelé (nickel chimique), ou protégé par vernissage époxydique.
- Têtes:** moulées sous pression en alliage d'aluminium ASTM B179, vernissées avec poudre epoxy-poliester ou Nickel chimique.
- Pistons:** moulés sous pression en alliage d'aluminium ASTM B179.
- Pignon:** en acier nickelé.
- Glissières:** en résine acétalique (LAT LUB 731320T).
- Vis:** en acier inoxydable AISI 304.
- Ressorts:** précomprimés en cartouche, vernissés avec poudre epoxydique.
- Joints d'étanchéité:** caoutchouc nitrile NBR (VITON ou EPDM sur demande).
- Graisse standard:** MoS₂.

DIMENSIONES GENERALES - GENERAL DIMENSIONS
ABMESSUNGEN - DIMENSIONS GÉNÉRALES

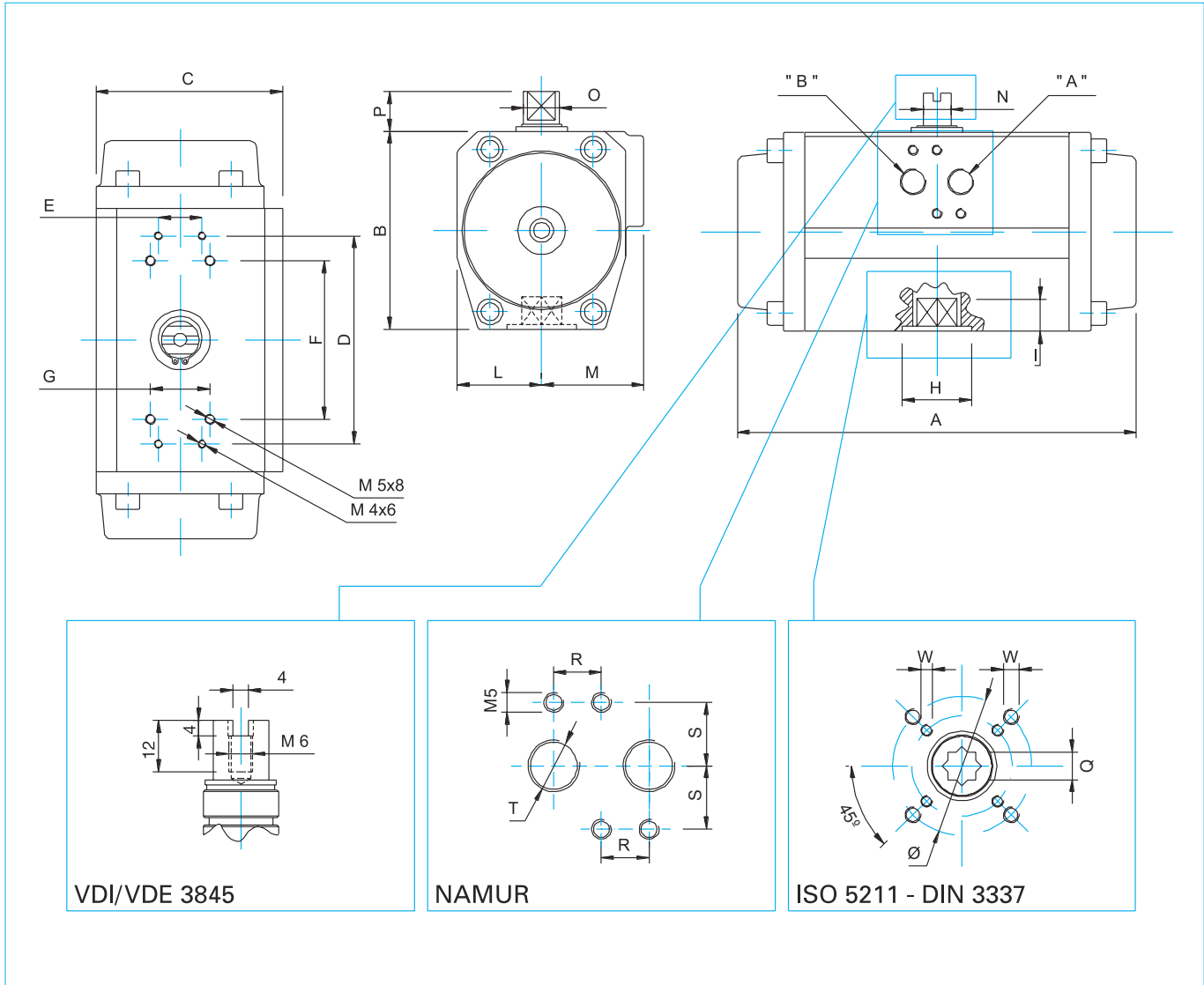

	Modelo Actuador - Model Actuator - Model Schwenkantriebe - Modèle Actionneur															
	CH032	CH042	CH050	CH063	CH075	CH085	CH100	CH115	CH125	CH145	CH160	CH180	CH200	CH240	CH270	
A	117	160	138	155,5	210	228	280,5	310	362	390	462	474	575	590	685	
B	45	57	67	83	100	110	125	142	155	175	196	220	240	298	332	
C	48	60,5	75	86	94	104	120	134	141	163	176	196	220	300	352	
D	-	-	-	-	105	105	105	139	139	139	139	139	139	-	-	
E	-	-	-	-	22	22	22	22	22	22	22	22	22	-	-	
F	50	80	80	80	80	80	80	130	130	130	130	130	130	130	130	
G	25	30	30	30	30	30	30	30	30	30	30	30	30	30	30	
H	-	25	25	30	35	40	55	55	55	70	75	75	100	100	130	
I	10	13	13	16	20	20	20	25	25	30	30	30	37	37	50	
L	22,5	27	33,5	38	42,5	49	55	63,5	69,5	80	88	98	110	150	166	
M	25,5	33,5	41,5	48	51,5	55	65	70,5	71,5	83	88	98	110	150	166	
T/ DIN 259	1/8"	1/8"	1/8"	1/4"	1/4"	1/4"	1/4"	1/4"	1/4"	1/4"	1/4"	1/4"	1/4"	1/2"	1/2"	
N	8	8	8	8	14	14	14	27	27	27	27	27	32	32	35	
O	12	12	12	12	18	18	18	36	36	36	36	36	42	60	80	
P	20	20	20	20	20	20	20	30	30	30	50	50	50	50	50	
Q	9	11	11	11	17	17	17	22	22	27	27	27	36	36	46	
R	12	12	12	12	12	12	12	12	12	12	12	12	12	20	20	
S	16	16	16	16	16	16	16	16	16	16	16	16	16	25	25	
DIAM. Ø	36	36/ 50	36/ 50	36/ 50	50/ 70	50/ 70	70/ 102	70/ 102	70/ 102	102/ 125	102/ 125	102/ 125	140	140	165	
W	M5	M5/ M6	M5/ M6	M5/ M6	M6/ M8	M6/ M8	M8/ M10	M8/ M10	M8/ M10	M10/ M12	M10/ M12	M10/ M12	M16	M16	M20	
ISO 5211	F03	F03/ F05	F03/ F05	F03/ F05	F05/ F07	F05/ F07	F07/ F10	F07/ F10	F07/ F10	F10/ F12	F10/ F12	F10/ F12	F14	F14	F16	

ACTUADORES NEUMÁTICOS 120° - PNEUMATIC ACTUATOR 120°
PNEUMATISCHE ANTRIEBE 120° - ACTIONNEURS PNEUMATIQUES 120°

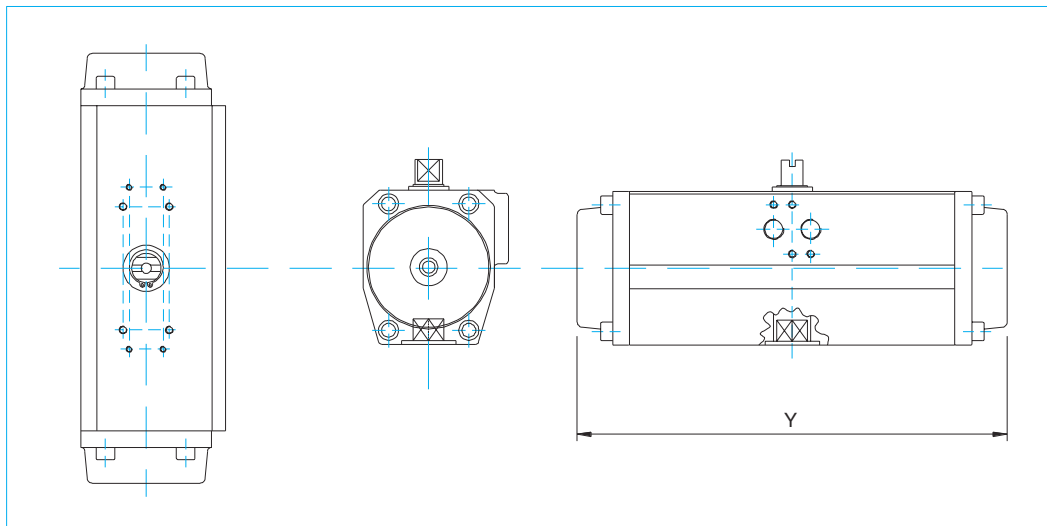

DA		Modelo Model Model Modèle																	
		CH032		CH042		CH050		CH063		CH075		CH085		CH100		CH115		CH125	
Y		mm	inch	mm	inch	mm	inch	mm	inch	mm	inch	mm	inch	mm	inch	mm	inch	mm	inch
		150	5.91	194	7.64	172	6.77	201	7.91	249	9.80	282	11.10	332	13.07	373	14.68	432	17.01
Volumen - Volumen Volumen - Volume	Lt.	0.10		0.21		0.27		0.58		0.70		1.15		2.10		3.40		4.60	
Abierto - Opening Offen - Ouvert	Sec.	0.60		0.60		0.70		0.75		0.75		0.75		1.00		1.10		1.40	
Cerrado - Closed Geschlossen - Fermé	Sec.	0.60		0.60		0.70		0.85		0.85		1.00		1.10		1.30		1.60	
Peso - Weight Gewicht - Poids	Kg.	0.55		1.00		1.30		1.90		3.30		4.80		6.70		10.6		13.4	

ACTUADORES NEUMÁTICOS 180° - PNEUMATIC ACTUATOR 180°
PNEUMATISCHE ANTRIEBE 180° - ACTIONNEURS PNEUMATIQUES 180°

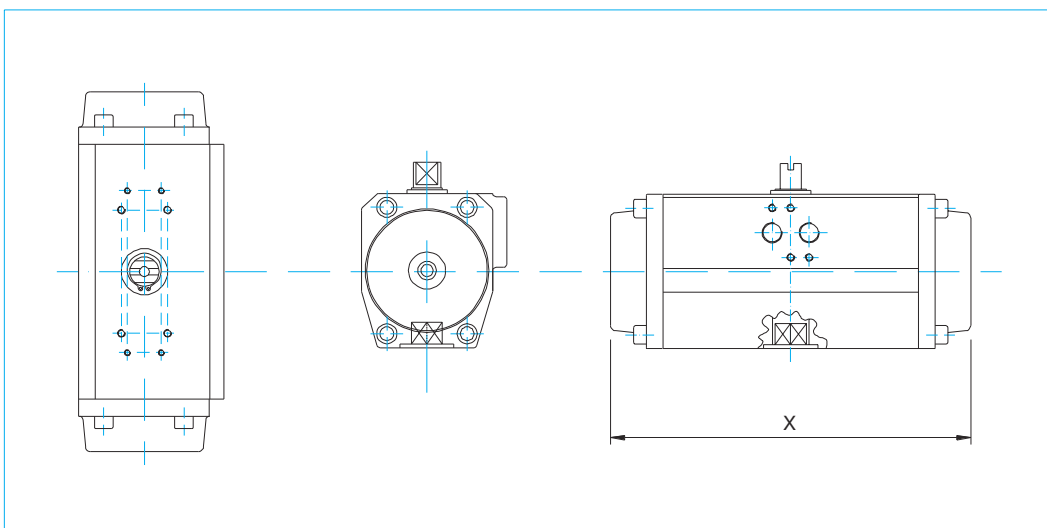

DA		Modelo Model Model Modèle																	
		CH032		CH042		CH050		CH063		CH075		CH085		CH100		CH115		CH125	
X		mm	inch	mm	inch	mm	inch	mm	inch	mm	inch	mm	inch	mm	inch	mm	inch	mm	inch
		195	7.68	230	9.05	211	8.31	220	8.66	298	11.73	338	13.31	401	15.79	462	18.19	570	22.44
Volumen - Volumen Volumen - Volume	Lt.	0.15		0.30		0.39		0.73		1.00		1.50		2.80		4.50		5.90	
Abierto - Opening Offen - Ouvert	Sec.	0.70		0.80		0.85		0.85		0.85		1.00		1.20		1.40		1.80	
Cerrado - Closed Geschlossen - Fermé	Sec.	0.70		0.80		0.85		1.00		1.00		1.40		1.50		1.70		2.10	
Peso - Weight Gewicht - Poids	Kg.	0.75		1.20		1.70		2.50		4.70		7.00		10.0		15.5		19.2	

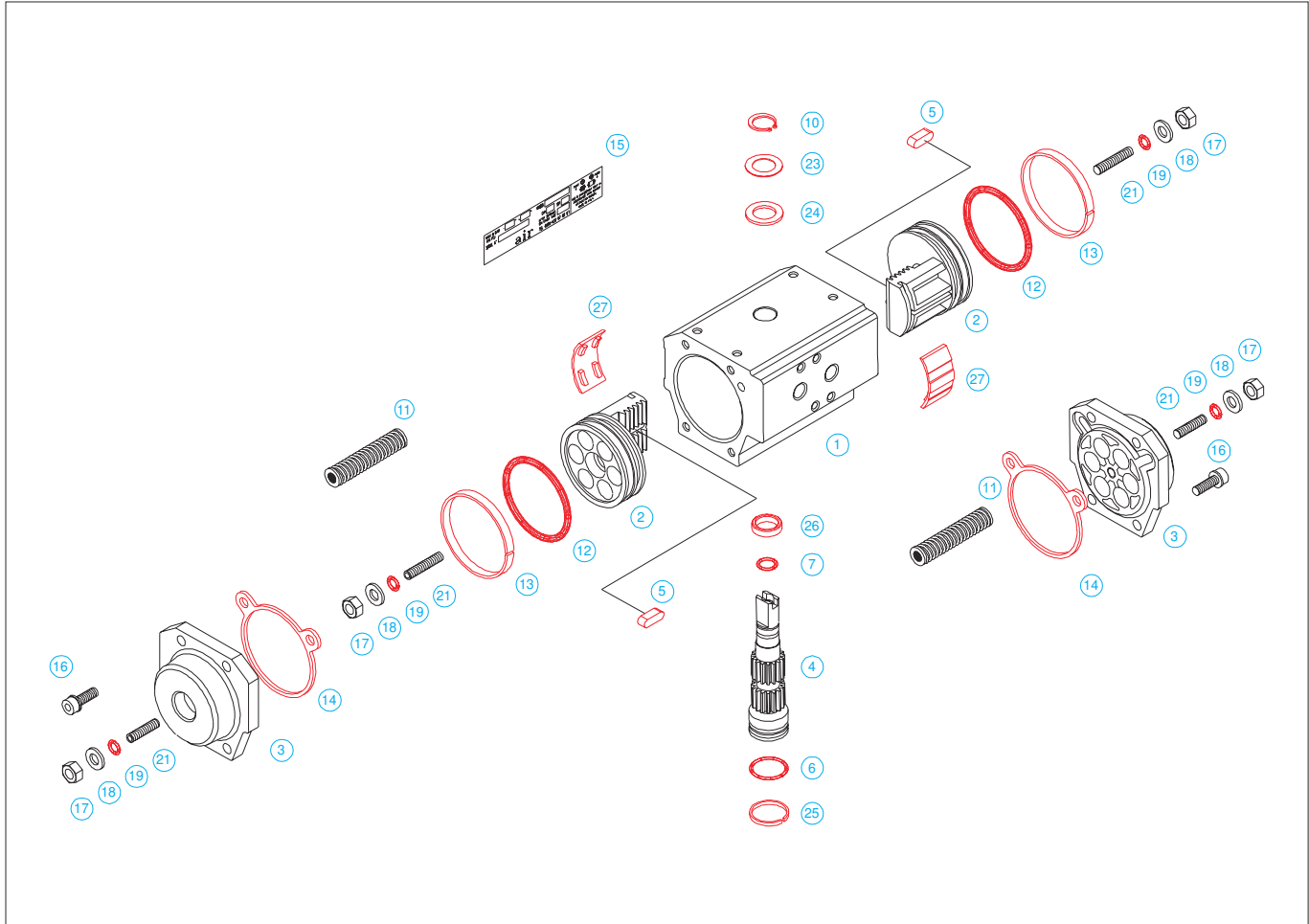

Pezas Parts Ersatzteile Pièces	Set recambio Spare parts set Ersatzteile gruppe Set Pièces de réchange	Cantidad Quantity	Descripción - Description - Beschreibung - Description			
1		1	CUERPO	BODY	KÖRPER	CORPS
2		2	PISTÓN	PISTON	KOLBEN PISTON	PISTON
3		2	TAPA	END CAP	DECKEL	COUVERCLE
4		1	PIÑÓN	PINION	RIEDEL	PIGNON
	- 5	2	GUÍA PISTÓN	PISTON PILOT KEY	FÜHRUNGSKEIL RITZEL	CLAVETTE GUIDAGE PISTON
	- 6	1	JUNTA INFERIOR PIÑÓN	O-RING LOWER PINION	O-RING UNTERES RITZEL	JOINT SUPERIEUR PIGNON
	- 7	1	JUNTA SUPERIOR PIÑÓN	O-RING UPPER PINION	O-RING OBERES RITZEL	JOINT INFÉRIEUR PIGNON
	- 10	1	CIRCLIP	SEEGER RING	SEEGERRING	BAGUE SEEGER
11			MUELLES	SPRING GROUP	FEDERGRUPE	GROUPE RESSORT
	- 12	2	JUNTA TAPA PISTÓN	O-RING FOR PISTON	O-RING DES RITZEL	JOINT PISTON
	- 13	2	ANILLO ANTIFRICCIÓN	ANTI-FRICTION RING	ANTI-FRIKTIONSRING RITZEL	BAGUE ANTI-FRICTION PISTON
	- 14	2	JUNTA TAPA	COVER GASKET	DECKELDICHUNG	JOINT COUVERCLE
15		1	PLACA IDENTIFICACIÓN	NAME PLATE	NAMENSSCHILD	PLAQUETTE D'IDENTIFICATION
16		8	TORNILLO TAPA	END CAP BOLT	DECKELFIXIERSCHRAUBE	VIS FIXAGE COUVERCLE
17		4	TUERCA	NUT	MUTTER	ECROU
18		2	ARANDELA	WASHER	UNTERLEGSCHLEIBE	RONDELLE
	- 19	1	JUNTA	O-RING	O-RING	O-RING
21		1	ESPÁRRAGO REGULACIÓN EXTERIOR	STROKE ADJUSTMENT	DECKELSTIFT	GRAIN DU COUVERCLE
	- 23	1	ARANDELA	PINION THRUST WASHER	DRUCKSCHEIBE RITZEL	RONDELLE
	- 24	1	ARANDELA NYLON	ANTI-FRICTION WASHER	ANTI-FRIKTIONUNTERLEGSCHLEIBE	RONDELLE ANTI-FRICTION
	- 25	1	GUÍA INFERIOR PIÑÓN	PINION LOWER BEARING	RITZELFÜHRUNGSRING	BAGUE INFÉRIEUR GUIDAGE
	- 26	1	GUÍA SUPERIOR PIÑÓN	PINION UPPER BEARING	OBERER RITZELFÜHRUNGSRING	BAGUE SUPERIEUR GUIDAGE
	- 27	2	PATÍN ANTIFRICCIÓN	PISTON BEARING	ANTI-FRIKTIONSGLEITBACKE KOLBEN	GLISSEUR ANTI-FRICTION
28		2	ESPÁRRAGO REGULACIÓN INTERIOR	PISTON DOWEL	KOLBENSTIFT	GRAIN DU PISTON

VARIANTES DE MONTAJE – ASSEMBLY VARIATIONS MONTAGEVARIANTEN - VARIANTES DE MONTAGE

A Muelles cierran la válvula - **Springs Closed the Valve**
Die federn (schliessen) das ventil - Les ressorts ferment la vanne

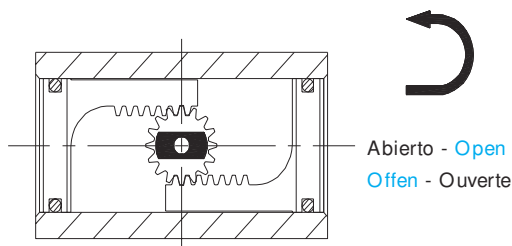
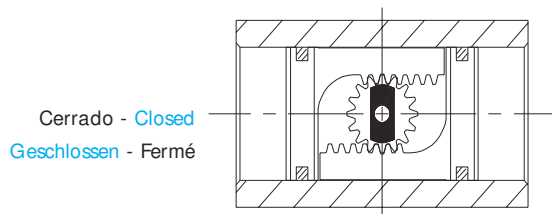

B Muelles cierran la válvula - **Springs Closed the Valve**
Die federn (schliessen) das ventil - Les ressorts ferment la vanne

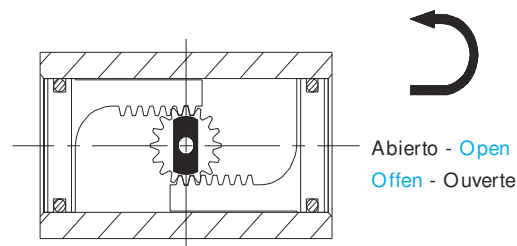
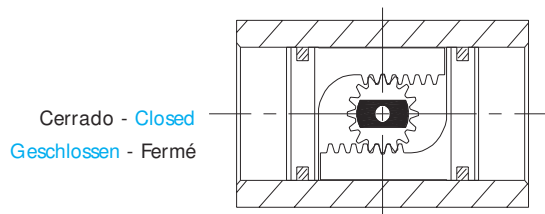

C Muelles abren la válvula - **Springs open the Valve**
Die federn oeffnen das ventil - Les ressorts ouvrent la vanne

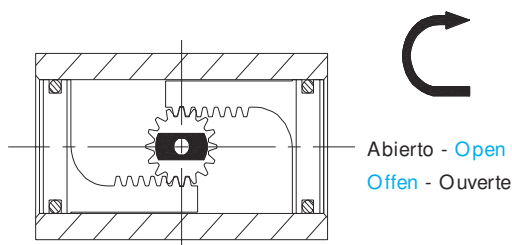
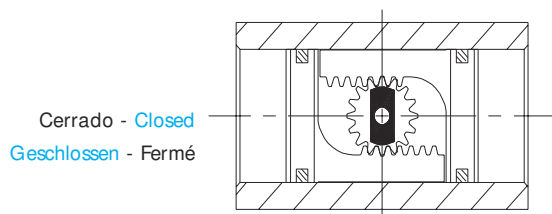

D Muelles abren la válvula - **Springs open the Valve**
Die federn oeffnen das ventil - Les ressorts ouvrent la vanne

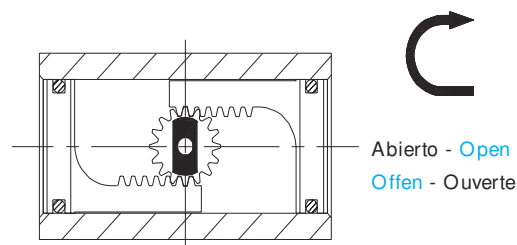
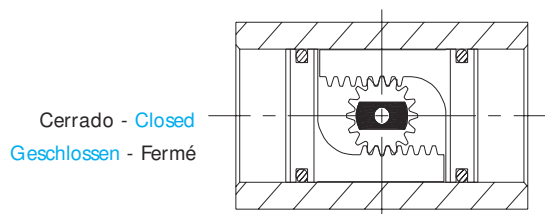

Vista Superior: Comprobar la posición de la entalla superior del piñón.

Top view: Note position of Shaft upper key.

Aufsicht: Beobachten sie die stellung des oberen schüssels des ritzels.

Vue de dessus: Observer la position de la clé supérieure du pignon.

PARES ACTUADORES DOBLE EFECTO EN Nm - **DOUBLE ACTING ACTUATORS TORQUE OUPUT IN Nm** DREHMOMENT Nm FÜR DER DOPPELTWIRKENDE SCHWENKANTRIEBE - **COUPLE ACTIONNEURS DOUBLE EFFET EN Nm**

Modelo Model	Model Modèle	PRESIÓN DE ALIMENTACIÓN DE AIRE EN bar AIR SUPPLY IN bar LUFTSPEISUNG IN bar PRESSION D'AIR MOTEUR EN bar								Peso - Weight Gewicht - Poids
		3	4	5	6	7	8	9	10	
CH032		-	5.0	6.3	7.6	8.8	10	11.4	12.6	0,420 Kgr.
CH042		6.5	8.7	10.9	13.0	15.2	17.3	19.5	21.7	0,870 Kgr.
CH050		9.2	12.3	15.4	18.5	21.5	24.6	27.7	30.8	1,070 Kgr.
CH063		16.5	22.0	27.5	33.0	38.5	44.0	49.5	55.0	1,600 Kgr.
CH075		35.1	46.8	58.5	70.2	81.9	93.6	105.3	117.0	2,900 Kgr.
CH085		53.4	71.2	89.0	106.9	124.7	142.4	160.3	178.1	4,200 Kgr.
CH100		89.2	110.9	138.6	166.4	194.1	221.8	249.5	277.3	5,800 Kgr.
CH115		137.2	183.0	228.7	274.5	320.2	366.0	411.7	457.5	9,200 Kgr.
CH125		180.5	240.7	300.9	361.1	421.2	481.4	541.6	601.8	11,900 Kgr.
CH145		260.1	346.8	433.5	520.2	606.9	693.6	780.3	867.0	15,500 Kgr.
CH160		355.5	473.4	591.7	710.1	828.4	946.8	1065.1	1183.5	20,500 Kgr.
CH180		479.0	638.6	798.3	958.0	1118	1277	1437	1597	30,500 Kgr.
CH200		665.6	887.5	1109.4	1333.3	1553.1	1775.0	1996.9	2218.8	43,000 Kgr.
CH240		1117.6	1490.2	1862.7	2235.3	2607.8	2980.4	3352.9	3725.4	60,000 Kgr.
CH270		1617.6	2156.8	2696.0	3235.2	3774.4	4313.6	4852.8	5392.0	94,000 Kgr.

POSICIONAMIENTO CORRECTO DE LOS MUELLES - RIGHT POSITION OF SPRINGS
 RICHTIGE STELLUNG FÜR DIE FEDER - POSITION CORRECTE DES RESSORT

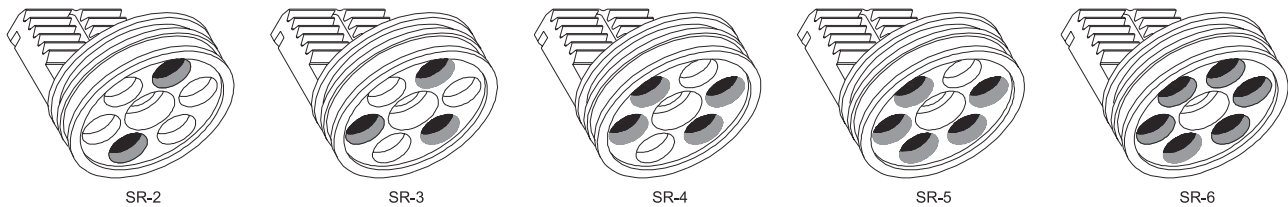

PARES ACTUADORES SIMPLE EFECTO EN NM - SPRING RETURN ACTUATORS TORQUE OUTPUT IN NM

DREHMOMENT NM FÜR EINFACHWIRKENDE SCHENKANTREBE - COUPLE DES ACTIONNEURS SIMPLE EFFET EN NM

Modelo Model Model Modèle	PRESIÓN DE ALIMENTACIÓN DE AIRE EN bar AIR SUPPLY IN bar LUFTSPEISUNG IN bar PRESSION D'AIR MOTEUR EN bar												Peso Weight Gewicht Poids		
	3		4		5		6		7		8		Para muelles Spring torque Federlauf Couple de ressorts		Kgr.
	0°	90°	0°	90°	0°	90°	0°	90°	0°	90°	0°	90°	0°	90°	
042 SR 2/ 2	4.0	2.0	6.2	4.2	8.4	6.4	10.6	8.6	12.7	10.7	14.9	12.9	4.5	2.5	0,890
042 SR 3/ 3			5.0	2.0	7.1	4.1	9.3	6.3	11.5	8.5	13.7	10.7	6.8	3.8	0,910
042 SR 4/ 4							8.1	4.1	10.2	6.2	12.4	8.4	9.0	5.0	0,930
050 SR 3/ 3	5.7	3.5	8.9	6.6	12.0	9.6	15.1	12.7	18.1	15.7	21.2	18.8	5.7	3.5	1,135
050 SR 4/ 4			7.7	4.7	10.8	7.7	13.9	10.8	16.9	13.8	20.0	16.9	7.7	4.7	1,160
050 SR 5/ 5					9.6	5.8	12.7	8.9	15.7	11.9	18.8	15.0	9.6	5.8	1,180
050 SR 6/ 6					8.4	3.9	11.5	7.0	14.5	10.0	17.6	13.1	11.5	7.0	1,200
063 SR 3/ 3	9.4	6.3	14.9	11.7	20.4	17.2	25.9	22.7	31.4	28.2	36.9	33.7	10.2	7.2	1,700
063 SR 4/ 4			12.3	8.3	17.8	13.8	23.3	19.3	28.8	24.8	34.3	30.3	13.7	9.7	1,830
063 SR 5/ 5					15.4	10.4	20.9	15.9	26.4	21.4	31.9	26.9	17.1	12.1	1,870
063 SR 6/ 6					13.0	7.0	18.5	12.5	24.0	18.0	29.5	23.5	20.5	14.5	1,800
075 SR 3/ 3	22.5	12.6	34.2	24.4	46.0	36.1	57.7	47.8	69.4	59.5	81.1	71.2	22.5	12.6	3,140
075 SR 4/ 4			30.0	16.9	41.8	28.6	53.5	40.3	65.2	52.0	76.9	63.7	30.0	16.9	3,210
075 SR 5/ 5					37.6	21.1	49.3	32.8	61.0	44.5	72.7	56.2	37.6	21.1	3,290
075 SR 6/ 6					33.4	13.6	45.1	25.3	56.8	37.0	68.5	48.7	45.1	25.3	3,370
085 SR 3/ 3	34.5	18.9	52.4	36.7	70.2	54.5	88.0	72.3	105.8	90.1	123.6	107.9	34.5	18.9	4,520
085 SR 4/ 4			46.1	25.2	63.9	43.0	81.7	60.8	99.5	78.6	117.3	96.4	46.1	25.2	4,620
085 SR 5/ 5					57.6	31.5	75.4	49.3	93.2	67.1	111.0	84.9	57.6	31.5	4,730
085 SR 6/ 6					51.5	20.0	69.1	37.8	86.9	55.6	104.7	73.4	69.1	37.8	4,830
100 SR 3/ 3	53.2	30.0	80.9	57.7	108.7	85.4	136.4	113.1	164.1	140.8	191.8	168.5	53.2	30.0	6,310
100 SR 4/ 4			70.9	40.0	98.7	67.7	126.4	95.4	154.1	123.1	181.8	150.8	70.9	40.0	6,480
100 SR 5/ 5					88.7	50.0	116.4	77.7	144.1	105.4	171.8	133.1	88.7	50.0	6,650
100 SR 6/ 6					78.7	32.2	106.4	60.0	134.1	87.7	161.8	115.4	106.4	60.0	6,820
115 SR 3/ 3	84.3	53.0	130.0	98.8	175.8	144.5	221.6	190.3	267.3	236.0	313.0	281.7	84.3	53.0	9,750
115 SR 4/ 4			112.3	70.7	158.1	116.4	203.9	162.2	249.6	207.9	295.3	253.6	112.3	70.7	9,940
115 SR 5/ 5					140.4	88.3	186.2	134.1	231.9	179.8	277.6	225.5	140.4	88.3	10,120
115 SR 6/ 6					122.7	60.2	168.5	106.0	214.2	151.7	259.9	197.4	168.5	106.0	10,300
125 SR 3/ 3	116.8	63.7	177.0	123.9	237.3	184.1	297.5	244.2	357.6	304.3	417.7	364.4	116.8	63.7	13,050
125 SR 4/ 4			155.7	85.0	216.0	145.2	276.2	205.3	336.3	265.4	396.4	325.5	155.7	85.0	13,440
125 SR 5/ 5					194.7	106.3	254.9	166.4	315.0	226.5	375.1	286.6	194.7	106.3	13,820
125 SR 6/ 6					173.4	67.4	233.6	127.5	293.7	187.6	353.8	247.7	233.6	127.5	14,200
145 SR 3/ 3	158.0	92.0	245.0	179.0	332.0	265.0	418.0	352.0	505.0	439.0	592.0	526.0	158.0	102.0	17,250
145 SR 4/ 4			211.0	123.0	298.0	210.0	384.0	269.0	471.0	383.0	558.0	470.0	224.0	136.0	17,840
145 SR 5/ 5					264.0	154.0	350.0	240.0	437.0	327.0	524.0	414.0	280.0	170.0	18,420
145 SR 6/ 6					230.0	98.0	316.0	184.0	403.0	271.0	490.0	358.0	336.0	204.0	19,000
160 SR 3/ 3	222.4	132.6	340.7	251.0	459.1	369.3	577.4	487.6	695.7	605.9	814.0	724.2	222.4	132.6	17,250
160 SR 4/ 4			296.5	176.9	414.9	295.2	533.2	413.5	651.5	531.8	769.8	650.1	296.5	176.9	17,840
160 SR 5/ 5					370.7	221.1	489.0	339.4	607.3	457.7	725.6	576.0	370.7	221.1	18,420
160 SR 6/ 6					326.5	147.0	444.8	265.3	563.1	383.6	681.4	501.9	444.8	265.3	24,900
180 SR 3/ 3	287.9	191.1	447.6	350.7	607.3	510.4	766.9	670.0	926.8	829.7	1140.0	1010.0	287.9	191.0	33,620
180 SR 4/ 4			383.9	254.7	543.6	414.4	703.3	574.0	862.9	733.7	1010.0	880.0	383.9	254.7	34,660
180 SR 5/ 5					479.9	318.4	639.6	478.1	792.2	637.7	925.6	776.0	479.9	318.4	35,700
180 SR 6/ 6					416.2	222.4	575.9	382.1	735.6	641.8	881.4	701.9	575.9	382.1	36,740
200 SR 3/ 3	423.6	242.0	644.7	463.8	867.4	685.8	1089	907.7	1311	1130	1533	1351	423.6	242.0	48,000
200 SR 4/ 4			564.8	322.6	786.7	544.6	1009	766.5	1230	988.4	1452	1209	564.8	322.6	49,670
200 SR 5/ 5					706.0	403.4	927.9	625.3	1150	847.2	1372	1068	706.0	403.4	51,330
200 SR 6/ 6					625.3	262.2	847.2	484.1	1069	706.0	1291	927.0	847.2	484.1	53,000
240 SR 3/ 3	664.0	453.6	1036.6	826.2	1409.1	1198.7	1781.7	1571.2	2154.2	1943.8	2526.8	2316.3	664.0	453.6	67,200
240 SR 4/ 4			885.4	604.8	1257.9	977.4	1630.5	1349.9	2003.0	1722.5	2375.6	2095.0	885.4	604.8	69,600
240 SR 5/ 5					1106.7	756.0	1479.3	1128.6	1851.8	1501.1	2224.4	1873.7	1106.7	756.0	72,000
240 SR 6/ 6					955.5	534.7	1328.1	907.2	1700.6	1279.8	2073.2	1652.3	1328.1	907.2	74,400
270 SR 3/ 3	912.5	705.1	1451.7	1244.3	1990.9	1783.5	2530.1	2322.7	3069.3	2861.9	3608.5	3401.1	912.5	705.1	103,500
270 SR 4/ 4			1216.7	940.2	1755.9	1479.4	2295.1	2018.6	2834.3	2557.8	3373.5	3097.0	1216.7	940.1	106,660
270 SR 5/ 5					1520.9	1175.5	2060.1	1714.4	2599.3	2144.4	3138.5	2792.8	1520.8	1175.1	109,830
270 SR 6/ 6					1285.8	871.0	1825.0	1410.2	2364.2	1953.6	2903.4	2488.6	1825.0	1410.2	113,000