















































Serie Ghilux

 6300 Pag. 12.9	 6310 Pag. 12.9	 6320 Pag. 12.9	 6330 Pag. 12.	 6340 Pag. 12.10	 6350 Pag. 12.10	 6400 Pag. 12.10	 6410 Pag. 12.10	 6420 Pag. 12.11
 6430 Pag. 12.11	 6440 Pag. 12.11	 6450 Pag. 12.12	 6460 Pag. 12.12	 6470 Pag. 12.12	 6490 Pag. 12.13	 6500 Pag. 12.13	 6540 Pag. 12.13	 6560 Pag. 12.14
 6570 Pag. 12.14	 6600 Pag. 12.14	 86300 Pag. 12.15	 86310 Pag. 12.15	 66300 Pag. 12.17	 66310 Pag. 12.17	 6700 Pag. 12.19	 6710 Pag. 12.20	 6720 Pag. 12.20
 6900 Pag. 12.21	 6910 Pag. 12.21	 6915 Pag. 12.22	 6920 Pag. 12.22	 6680 Pag. 12.23	 10740 Pag. 12.23	 10741 Pag. 12.23	 10760 Pag. 12.23	 10761 Pag. 12.23
 6065 Pag. 12.25	 6066 Pag. 12.25	 6067 Pag. 12.27	 6068 Pag. 12.27	 6069 Pag. 12.28	 New 6074 Pag. 12.31	 New 6075 Pag. 12.32	 6035 Pag. 12.33	 6036 Pag. 12.35
 6037 Pag. 12.35	 6038 Pag. 12.35							

your notice - Aignep behält sich das Recht vor, Daten ohne Ankündigung zu ändern - Aignep se réserve le droit de modifier les données sans préavis
 limensões sem prévio aviso / AGGIORNAMENTO - UPDATED - STAND - ATUALIZAÇÃO - ATUALIZAÇÃO: 03/2016



VALVOLE A SFERA
 BALL VALVES
 KUGELHÄHNE
 VANNES À BILLE
 VÁLVULAS A ESFERA
 VÁLVULAS DE ESFERA



Serie Ghilux

IT

Inventate e ingegnerizzate da Aignep le valvole a sfera Ghilux sono state una rivoluzione già negli anni 90'. Di minimi ingombri e performanti queste micro valvole sono la risposta ottimale alla crescente richiesta di miniaturizzazione. Disponibili a 2 e 3 vie, con sfiato e attraversamento parete sono disponibili in ben 25 modelli differenti, possono intercettare differenti tipologie di fluidi. Possibilità di realizzare rubinetti con tenute differenti in FKM, EPDM e HNBR. Versione in Aisi 316L. A completamento dell'offerta Aignep dispone di rubinetti a 2 e 3 vie di dimensioni tradizionali.

Principali vantaggi

- A 2 e 3 vie e con spurgo
- Da 1/8 a 3/4 nelle filettature BSPP, BSPT e NPT
- Passaparete
- Tenute differenti in base alle applicazioni
- Leggerezza ed ingombro ridotto
- Inserti intercambiabili colorati per identificazione
- Silicon Free

Applicazioni

- Aria Compressa e Strumenti
- Automazione Pneumatica
- Intercettazione Fluidi
- Food & Beverage
- Life & Sciences
- Gas inerti, vuoto
- Settore Termoidraulico

GB

The GHILUX miniature ballvalves have been created and engineered by Aignep in the 90's. The supercompact dimensions and the excellent performance respond to the growing demand of miniaturization.

Many available version: 2 or 3-ways, with exhaust, push-in, compression, etc.

25 different configurations to drive multiple fluids. On demand FKM, EPDM and HNBR.

To complete the range traditional ball valves.

Main advantages

- 2-3 ways with exhaust
- Threads 1/8 to 3/4 - BSPP, BSPT, NPT
- Bulkhead
- Multiple fluids
- Supercompact dimension
- Coloured plates for identification
- Silicon Free

Application

- Compressed Air, Tools
- Pneumatic Automation
- Fluidtechnology
- Food & Beverage
- Life & Sciences
- Inert Gases, Vacuum
- Plumbing

DE

Die GHILUX Miniatur-Kugelhähne wurden in den 90er Jahren von Aignep entwickelt und kreiert.

Die superkompakten Abmessungen und die ausgezeichnete Leistung antworten auf die wachsende Nachfrage nach Miniaturisierung. Viele erhältliche Versionen: 2 oder 3-Wege, mit Entlüftung, mit Steckanschluss, etc.

25 verschiedene Konfigurationen für den Transport vieler Medien. Auf Anfrage FKM, EPDM und HNBR Dichtungen. Als Ergänzung zum traditionellen Kugelhahn Sortiments.

Hauptvorteile

- 2-3 Wege mit Entlüftung
- Gewinde 1/8 bis 3/4" - BSPP, BSPT, NPT
- Schottmontage
- Verschiedene Medien
- Superkompakte Abmessung
- Farbige Schilder zur Kennzeichnung
- Silikonfrei

Anwendungen

- Druckluft, Werkzeuge
- Pneumatische Automation
- Fluidtechnik
- Lebensmittel & Getränke
- Life Sciences
- Inertgase, Vakuum
- Sanitär

FR

Les robinets à boisseau sphérique GHILUX ont été conçus par Aignep dans les années 90. L'extrême compacité et l'excellente performance des produits répondent aux demandes croissantes dans la miniaturisation. Nombreuses versions disponibles: 2 ou 3 voies, avec échappement, raccordement instantané, à olive, etc. 25 configurations différentes pour transporter différents fluides. Version avec joint FKM, EPDM HNBR sur demande. Les robinets GHILUX complètent notre offre de robinets standards à boisseau sphérique.

Principaux avantages

- 2-3 voies, male -femelle- avec échappement
- Filetages de 1/8 à 3/4 - BSPP, BSPT, NPT
- A passage de cloison
- Nombreux fluides
- Extrême compacité
- Plaques de couleur pour l'identification des circuits
- Sans Silicone

Applications

- Air comprimé
- Automatisations pneumatiques
- Agro alimentaire
- Laboratoire
- Gaz neutres, vide
- Plomberie

ES

Inventadas y desarrolladas por Aignep las válvulas de esfera Ghilux eran ya una revolución en los años 90'. De reducidas dimensiones y excelente rendimiento estas micro válvulas son la respuesta óptima a la creciente demanda de miniaturización. Disponibles de 2 y 3 vías, con escape, automáticas, pasatabiques, compresión, 25 diferentes configuraciones para interceptar diferentes tipologías de fluidos. Posibilidad bajo demanda en FKM, EPDM y HNBR. Versión en Inox AISI 316L. Para completar la gama Aignep dispone de válvulas de esfera 2 y 3 vías de dimensiones tradicionales.

Principales ventajas

- A 2 y 3 vías y con escape
- De 1/8 a 3/4 con roscas BSPP, BSPT y NPT
- Pasatabiques
- Estanqueidad diferente en base a las aplicaciones
- Ligereza y dimensiones reducidas
- Insertos intercambiables de color para identificación
- Libres de silicona

Aplicaciones

- Aire comprimido y herramientas
- Automatización neumática
- Intercepción de fluidos
- Alimentos y bebidas
- Life & Sciences
- Gases inertes, vacío
- Sector termo hidráulico

PT

As válvula-esfera miniatura da série GHILUX foram criadas e desenvolvidas pela Aignep nos anos 90. As dimensões super-compactas e a excelente performance, atende ao crescimento de demanda de miniaturização solicitada pelo mercado moderno. Várias versões estão disponíveis: 2 ou 3-vias, com exaustão, conexão push-in, conexão de compressão, etc. 25 configurações diferentes para conduzir múltiplos fluidos. Sob encomenda: vedações em FKM, EPDM e HNBR para completar o range tradicional das válvulas-esfera.

Principais vantagens

- 2-3 viascom escape
- Roscas de 1/8 a 3/4 - BSPP, BSPT, NPT
- Modelo passa-muro
- Múltiplos fluidos
- Dimensões Super-compactas
- Linguetas coloridas para fácil identificação
- Livre de Silicone

Aplicações

- Ar Comprimido, Ferramentas
- Automação Pneumática
- Fluidos
- Alimentos e Bebida
- Life & Sciences
- Gases Inertes, Vácuo
- Encanamento



CARATTERISTICHE TECNICHE
 TECHNICAL CHARACTERISTICS
 TECHNISCHE ANGABEN
 CARACTÉRISTIQUES TECHNIQUES
 CARACTERÍSTICAS TÉCNICAS
 CARACTERÍSTICAS TÉCNICAS



Norma di Riferimento
 Reference Standard
 Entspricht Der Norm
 Conforme à La Norme
 Normativa de Referencia
 Norma de Referência

- 1907/2006 REACH ✓
- 2011/65/CE RoHS ✓
- 97/23/CE (PED)
- BS EN 331:1998
- SILICON FREE

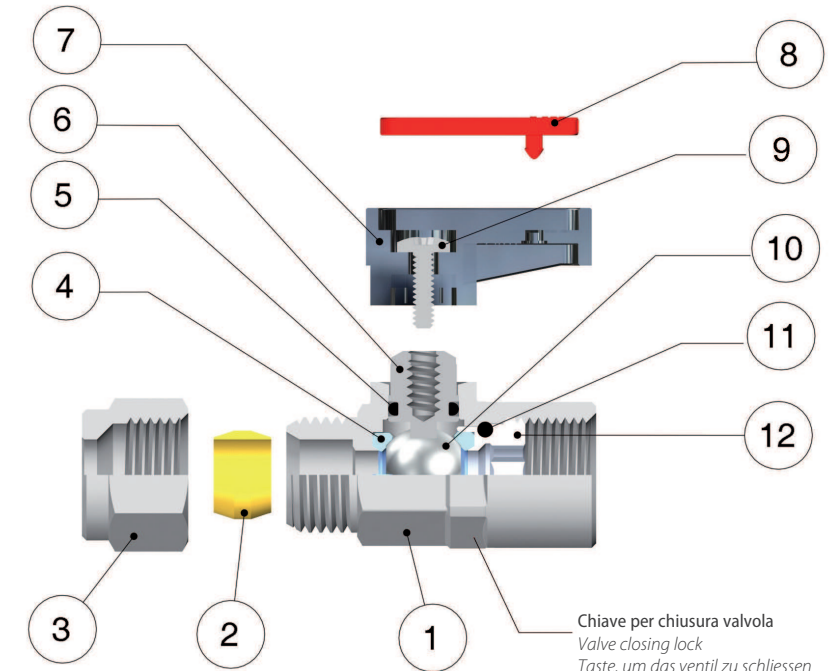

Chiave per chiusura valvola
 Valve closing lock
 Taste, um das Ventil zu schliessen
 Clé pour vanne de fermeture
 Clave para el cierre de la válvula
 A chave para o fecho da válvula

FKM - EPDM - HNBR A RICHIESTA
 IF REQUESTED FKM - EPDM - HNBR
 FKM - EPDM - HNBR AUF ANFRAGE
 FKM - EPDM - HNBR SUR DEMANDE
 FKM - EPDM - HNBR BAJO PEDIDO
 FKM - EPDM - HNBR SOB ENCOMENDA

Materiali e Componenti	IT
1	Corpo in Ottone cromato
2	Ogiva in Ottone (PTFE a richiesta)
3	Dado in Ottone cromato
4	Guarnizione sede sfera in PTFE
5	Guarnizione O-RING in NBR (FKM-EPDM-HNBR a richiesta)
6	Albero in Ottone cromato
7	Maniglia in PA66 Caricato vetro
8	Piastrina in Resina Acetalica
9	Vite in acciaio
10	Sfera in Ottone cromato
11	Guarnizione O-RING in NBR (FKM-EPDM-HNBR a richiesta)
12	Ghiera o raccordo in Ottone

Component Parts and Materials	GB
1	Chrome Nickel-plated Brass Body
2	Brass Olive (if Requested PTFE)
3	Chrome Nickel-plated Brass Nut
4	PTFE Seats
5	NBR Seal O-RING (FKM-EPDM-HNBR if required)
6	Chrome Nickel-plated Brass Spindle
7	PA66 Glass reinforced Handle
8	Acetalic resin Plate
9	Steel Screw
10	Chrome Nickel-plated Brass Ball
11	NBR Seal O-RING (FKM-EPDM-HNBR if required)
12	Brass Fitting

Komponenten und Materialien	DE
1	Körper Messing verchromt
2	Klemmring Messing (PTFE auf Anfrage)
3	Überwurfmutter Messing verchromt
4	Kugelsitzdichtung PTFE
5	O-Ring NBR (FKM-EPDM-HNBR auf Anfrage)
6	Spindel Messing verchromt
7	Handgriff PA66 Glasfaser verstärkt
8	Griffplatte Acetal
9	Schraube Stahl
10	Kugel Messing verchromt
11	O-Ring NBR (FKM-EPDM-HNBR auf Anfrage)
12	Gewindeinsatz Messing

Matériels et Composants	FR
1	Corps: laiton chromé
2	Bague: laiton (sur demande en PTFE)
3	Ecrou: laiton nickelé
4	Joint de siège: PTFE
5	Joint Torique NBR (sur demande en FKM-EPDM-HNBR)
6	Entraîneur: laiton chromé
7	Manette: PA66 chargé en fibre de verre
8	Plaquette de manette: résine acétal
9	Vis: acier
10	Bille: laiton chromé
11	Joint torique NBR (sur demande en FKM-EPDM-HNBR)
12	Ecrou de blocage: laiton

Materiales y Componentes	ES
1	Cuerpo en latón cromado
2	Bicono en latón (PTFE bajo demanda)
3	Tuerca en latón cromado
4	Junta sede esfera en PTFE
5	Junta tórica O-RING en NBR (FKM-EPDM-HNBR bajo demanda)
6	Eje en latón cromado
7	Maneta en PA66 con fibra de vidrio
8	Plaqueta en PA6
9	Tornillo en acero
10	Esfera en latón cromado
11	Junta tórica O-RING en NBR (FKM-EPDM-HNBR bajo demanda)
12	Racor en latón

Materiais e Componentes	PT
1	Corpo em Latão Cromado
2	Bucha em Latão (PTFE sob encomenda)
3	Porca em Latão Cromado
4	Vedação da sede da esfera em PTFE
5	Vedação O-RING em NBR (FKM-EPDM-HNBR sob encomenda)
6	Eixo em Latão Cromado
7	Manopla em PA66 e fibra de vidro
8	Plaqueta de Resina Acetálica
9	Parafuso em aço
10	Esfera em Latão Cromado
11	Vedação O-RING em NBR (FKM-EPDM-HNBR sob encomenda)
12	Conexões em Latão



Temperature

- Temperatures
- Temperatur
- Températures
- Temperaturas
- Temperaturas

- 20 °C	FKM	EPDM	HNBR
+ 80 °C	- 15 °C	- 40 °C	- 30 °C
	+ 130 °C	+ 130 °C	+ 130 °C



Pressioni

- Pressures
- Druckbereich
- Pressions
- Presiones
- Pressões

-0.99 bar (-0.099 MPa)
20 bar (2 MPa)



Filettatura

Gas conforme ISO 7.1, BS 21, DIN 2999
Gas cilindrica conforme ISO 228 Classe A.

IT

Threads

Gas in conformity with ISO 7.1, BS 21, DIN 2999.
Parallel gas in conformity with ISO 228 Class A.

GB

Gewindearten

Gewinde nach Norm ISO 7.1, BS 21, DIN 2999.
Zylindrisches Gewinde nach Norm ISO 228 Classe A.

DE

Filetages

Filetage conforme: ISO 7.1, BS 21, DIN 2999.
Filetage cylindrique conforme: ISO 228 Class A.

FR

Roscas

Gas conforme ISO 7.1, BS 21, DIN 2999
Gas cilíndrica conforme ISO 228 Classe A.

ES

Roscas

Gas conforme ISO 7.1, BS 21, DIN 2999.
Gas paralela conforme ISO 228 Classe A.

PT



Fluidi compatibili

Aria compressa / Acqua / Oli
1ª e 2ª famiglia di gas a media pressione.
3ª famiglia di gas a bassa pressione.

Fluids

Compressed air / Water / Oils
1st and 2nd family gases at medium pressure.
3rd family gases at low pressure.

Geeignete Medien

Druckluft / Wasser / Oel
1. und 2. Familie von Gasen für Mitteldruck.
3. Familie von Gasen für Niederdruck.

Fluides compatibles

Air comprimé / Eau / Huile
Famille 1 et 2 des gazes à moyenne pression.
Famille 3 des gazes à base pression.

Fluidos compatibles

Aire comprimido / Agua / Aceite
1ª y 2ª familia de gases a media presión.
3ª familia de gas a baja presión.

Fluidos compatíveis

Ar comprimido / Água / Óleos
1ª e 2ª familia de gás a média pressão.
3ª familia de gás a baixa pressão.

DIAGRAMMA PRESSIONE - TEMPERATURA

PRESSURE - TEMPERATURE RATINGS DIAGRAM
DRUCK - TEMPERATUR DIAGRAMM
DIAGRAMME PRESSION - TEMPÉRATURE
DIAGRAMA PRESIÓN-TEMPERATURA
DIAGRAMA DE PRESSÃO-TEMPERATURA

PTFE + FKM

PTFE + NBR

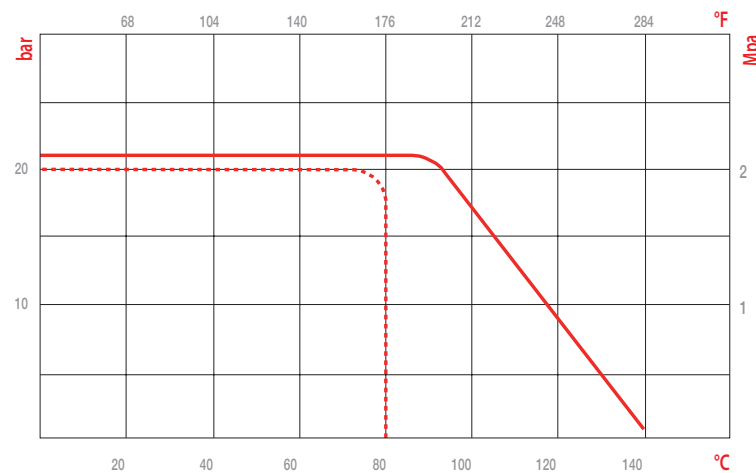

CURVE CARATTERISTICHE DI FLUSSO PER ARIA RELATIVE ALLE VALVOLE A SFERA GHILUX ART. 6400 FEMMINA-FEMMINA

CHARACTERISTIC CURVES OF FLOW FOR AIR PERTINENT TO THE BALL VALVES GHILUX ART. 6400 FEMALE-FEMALE
DURCHFLOSSKENNLINIEN FÜR DRUCKLUFT ANGEZEIGEN FÜR DIE KUGELHÄHNE GHILUX ART. 6400 INNEN-/INNENGEWINDE
CARACTÉRISTIQUES DES DÉBITS POUR L'AIR COMPRIMÉ VALABLE POUR LES VANNES À BILLE GHILUX ART. 6400 FEMELLE/FEMELLE
CURVA CARACTERÍSTICA DE FLUJO PARA AIRE RELATIVO A LAS VÁLVULAS A ESFERA GHILUX ART.6400 HEMBRA-HEMBRA
CURVAS CARACTERÍSTICAS DE VAZÃO PARA AR RELATIVAS ÀS VÁLVULAS DE ESFERA GHILUX CÓD. 6400 FÊMEA-FÊMEA

NI/min

Portata
Flow rate
Durchfluss
Débit
Caudal
Vazão

P1 (bar)

Pressione di entrata
Inlet Pressure
Eingangsdruk
Pression d'entrée
Presión de entrada
Pressão de entrada

P2 (bar)

Pressione di uscita
Outlet Pressure
Ausgangsdruck
Pression de sortie
Presión de salida
Pressão de saída

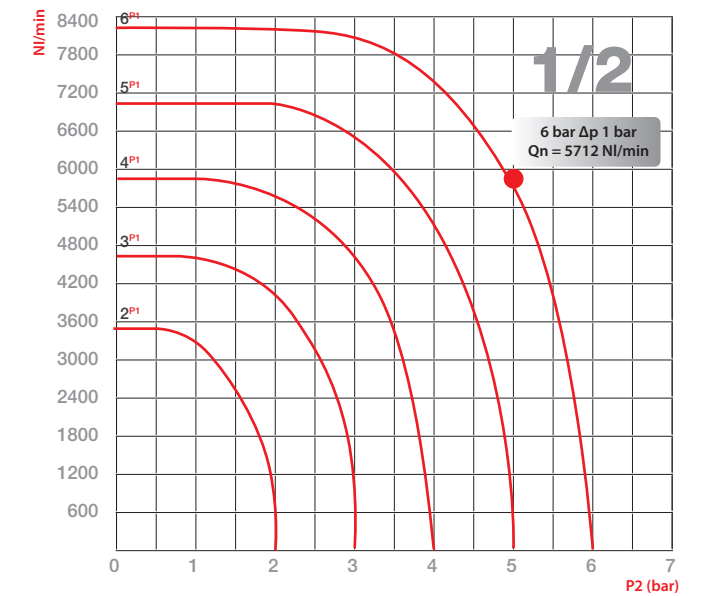
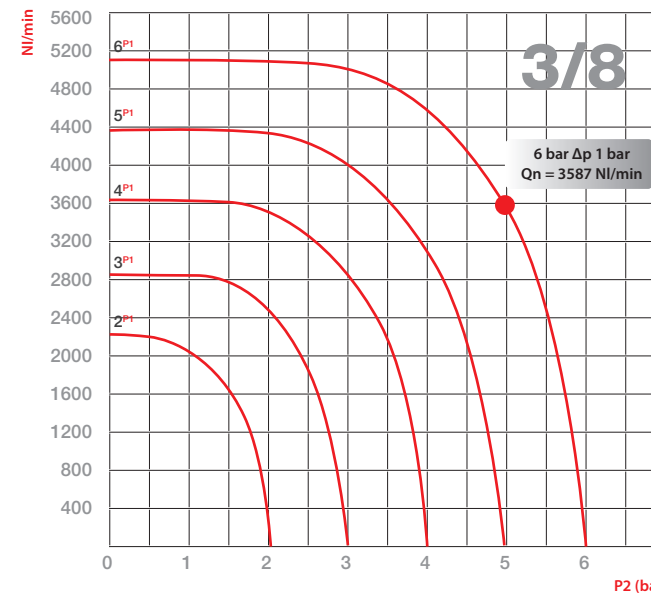
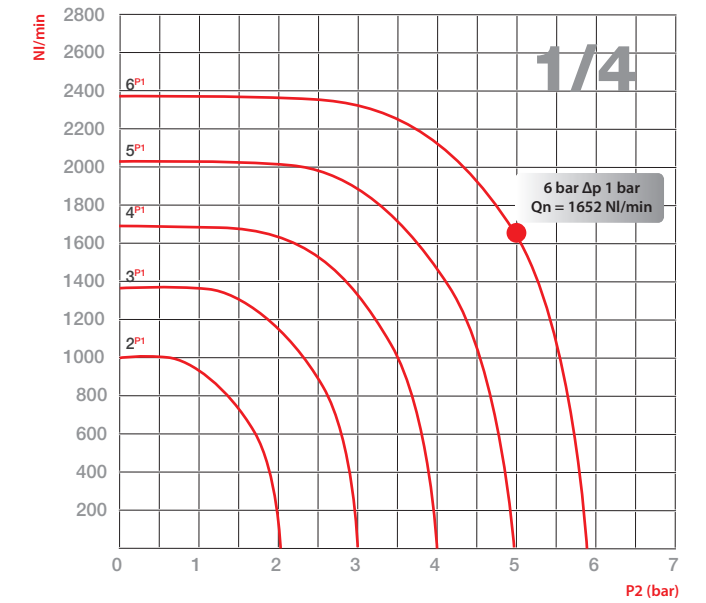
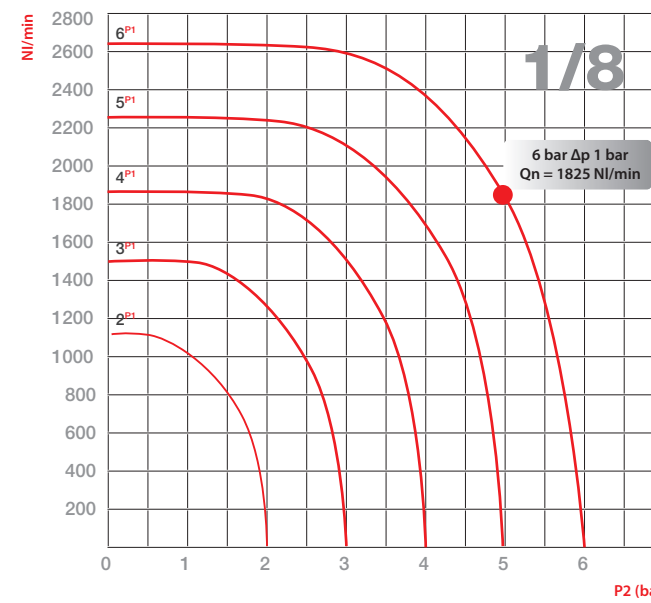



DIAGRAMMA DELLA CARATTERISTICA PORTATA-PERDITA DI CARICO RELATIVO ALLE VALVOLE A SFERA GHILUX ART. 6400 FEMMINA-FEMMINA PER ACQUA

DIAGRAM OF THE FLOW RATE AND PRESSURE DROP CHARACTERISTICS PERTINENT TO THE BALL VALVES GHILUX ART. 6400 FEMALE-FEMALE FOR WATER
 DURCHFLOSS- UND DRUCKABFALLDIAGRAMM FÜR WASSER ANGEZEIGT FÜR DIE KUGELHÄHNE GHILUX ART. 6400 INNEN-/INNENGEWINDE
 CARACTÉRISTIQUES DES DÉBITS ET DES PERTES DE CHARGE POUR L'EAU VALABLE POUR LES VANNES À BILLE GHILUX ART. 6400 FEMELLE/FEMELLE
 DIAGRAMA DE LAS CARACTERÍSTICAS CAUDAL-PÉRDIDA DE CARGA RELATIVO A LAS VÁLVULAS A ESFERA ART.6400 HEMBRA-HEMBRA PARA AGUA
 DIAGRAMA DA CARACTERÍSTICA DE VAZÃO-PERDA DE CARGA RELATIVO ÀS VÁLVULAS DE ESFERA GHILUX CÓD. 6400 FÊMEA-FÊMEA PARA ÁGUA

ΔP (DAPA)
 Perdita di carico
 Pressure drop
 Druckabfall
 Pertes de charge
 Pérdida de carga
 Perda de carga

1 DAPA = 1,019 mm H₂O

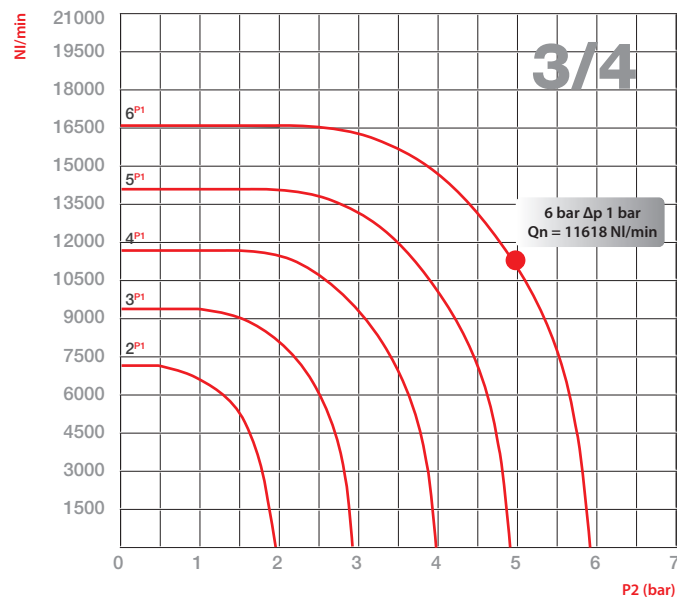
QW (Kg/h)
 Portata
 Flow rate
 Durchfluss
 Débit
 Caudal
 Vazão

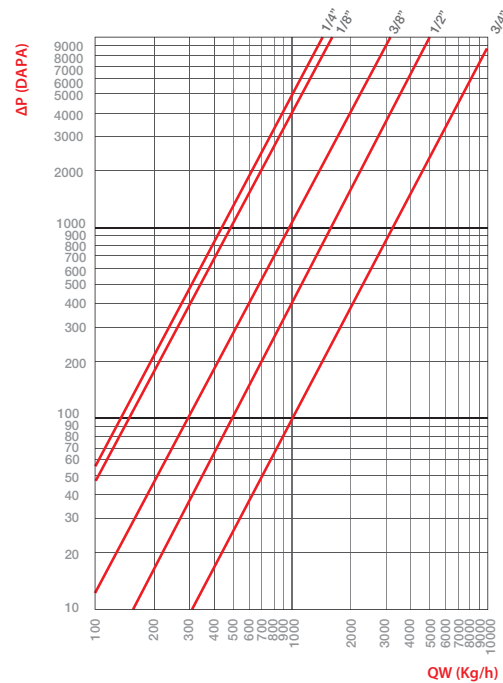

Misura Size Größe Dimension Medida Tamanho	Coefficiente di Portata Idraulica Factor of Hydraulic flow rate Hydraulische Durchflusskoeffizienten Coefficient Hydraulique de Débit Coeficiente de Caudal Hidráulico Coeficiente de Vazão Hidráulica	Kv (Kg/h)	m ³ /h
1/8"		1614	1,6
1/4"		1461	1,4
3/8"		3164	3,1
1/2"		5051	5
3/4"		10274	10,2

Coefficienti di Portata Kv
 Riportiamo in tabella il coefficiente di portata Kv delle valvole a sfera GHILUX, ricordando che tale coefficiente rappresenta la quantità d'acqua che attraversa la valvola nell'unità di tempo (Kg/h) alla temperatura di 15,5° C e che determina una caduta di pressione unitaria.

Flow Rate Factors Kv
 On the following table we specify the flow rate factor Kv of the ball valves GHILUX, we remind you that this factor represent the quantity of water that cross the valve in the unit time (Kg/h) at the temperature of 15,5° C and it determines a drop of unitary pressure.

Durchflusskoeffizienten Kv
 Die folgende Tabelle zeigt den Durchflusskoeffizienten Kv der GHILUX Kugelhähne. Dieser Faktor steht für die Wassermenge, welche den Kugelhahn in der Zeiteinheit (Kg/h) bei einer Temperatur von ca. 15,5° C durchfließt und er bestimmt einen einheitlichen Druckabfall.

Coefficient de Débit Kv
 Les valeurs Kv mentionnées sur le graphique sont valables pour les vannes à billes GHILUX. Pour information, la valeur Kv correspond à la valeur pratique du débit d'eau en kg/h, à une température d'environ 15,5°C, sous un delta P de 1 bar à travers le robinet complètement ouvert.

Coeficientes de Caudal Kv
 Representamos en la tabla los coeficientes de caudal Kv de las válvulas a esfera serie GHILUX, recordando que este coeficiente representa la cantidad de agua que pasa por la válvula por unidad de tiempo (Kg/h) a la temperatura de 15,5°C y que determina una caída de presión unitaria.

Coeficientes de Vazão Kv
 Especificamos na tabela a seguir o coeficiente de vazão Kv das válvulas de esfera GHILUX, recordando que tal coeficiente representa a quantidade de água que atravessa a válvula na unidade de tempo (Kg/h) a uma temperatura de 15,5° C e que determina uma queda de pressão unitária.



- Opzioni
- Option
- Optionen
- Options
- Opciones
- Opções

CODICE ARTICOLO ARTICLE CODE ARTIKEL-NUMMER CODE ARTICLE CÓDIGO ARTÍCULO CÓDIGO DO PRODUTO	MISURA SIZE GRÖSSE DIMENSIONS MEDIDA TAMANHO	COLORE PIASTRINA COLOUR OF THE PLATE GRIFFPLATTEN FARBEN COULEUR DE LA PLAQUETTE COLOR PLAQUETA COR PLAQUETA	TIPO DI GUARNIZIONE TYPE OF THE SEAL ART.DER DICHTUNG TYPE DE JOINT TIPO DE JUNTA TIPO DE VEDAÇÃO	TIPO MANIGLIA TYPE OF HANDLES ART.DES HANDGRIFES TYPE DE MANETTE TIPO DE MANETA TIPO DE MANETA	TIPO DI OGIVA TYPE OF OLIVE ART.DES KLEMMRINGES TYPE DE BAGUE TIPO DE BICONO TIPO DE BUCHA
---	---	---	--	---	---

- 6430
- 10 - 3/8
- RED PLATE
- NBR
- BRASS Olive

RO Piastrina Rossa
Red Plate
Griffplatte Rot
Plaquette Rouge
Plaqueta Roja
Plaqueta Vermelha

NBR

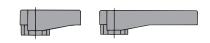

Maniglia CORTA STANDARD per valvola da 1/8 - 1/4 - 3/8 - 1/2
Maniglia LUNGA STANDARD per Valvola da 3/4
 Standard SHORT Handle for Valve 1/8-1/4-3/8-1/2
 Standard LONG Handle for Valve 3/4
 Handgriff KURZ Standard für 1/8-1/4-3/8-1/2
 Handgriff LANG Standard für 3/4
 Manette COURTE en standard pour 1/8-1/4-3/8-1/2
 Manette LONGUE en standard pour 3/4
 Maneta CORTA estándar para válvula de 1/8-1/4-3/8-1/2
 Maneta LARGA estándar para válvula de 3/4
 Manopla CURTA standard para válvula de 1/8-1/4-3/8-1/2
 Manopla LONGA standard para válvula de 3/4



Ogiva OTTONE
Brass OLIVE
Klemming MESSING
Bague LAITON
Bicono LATÓN
Bucha em LATÃO

Su richiesta
If required
Auf Anfrage
Sur demande
Bajo demanda
Sob encomenda

BL Piastrina Blu
Blue Plate
Griffplatte Blau
Plaquette Bleu
Plaqueta Azul

VE Piastrina Verde
Green Plate
Griffplatte Grün
Plaquette Verte
Plaqueta Verde

BN Piastrina Bianca
White Plate
Griffplatte Weiss
Plaquette Blanche
Plaqueta Blanca

GI Piastrina Gialla
Yellow Plate
Griffplatte Gelb
Plaquette Jaune
Plaqueta Amarela

GAS:

GI Piastrina Gialla EN 331
Yellow Plate EN 331
Griffplatte Gelb EN 331
Plaquette Jaune EN 331
Plaqueta Amarela EN 331

FKM HNBR



Maniglia LUNGA
LONG Handle
Handgriff LANG
Manette LONGUE
Maneta LARGA
Manopla LONGA



Ogiva PTFE
PTFE Olive
Klemming PTFE
Bague PTFE
Bicono PTFE
Bucha em PTFE

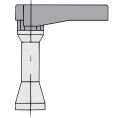

Maniglia LUNGA con Prolunga albero di comando
Long HANDLE with Spindle Extension
Handgriff LANG mit verlängerter Schaltwelle
Manette LONGUE avec entraineur rallongé
Maneta LARGA prolongada
Manopla LONGA com Prolongamento no eixo de comando

6300

VALVOLA FEMMINA RP ISO 7 - FEMMINA RP ISO 7

FEMALE RP ISO 7 - FEMALE RP ISO 7 VALVE
 KUGELHAHN INNENGEW. RP ISO 7 - INNENGEW. RP ISO 7
 VANNE À BILLE, FILETAGE FEMELLE RP ISO 7 - FILETAGE FEMELLE RP ISO 7
 VÁLVULA HEMBRA RP ISO 7 - HEMBRA RP ISO 7
 VÁLVULA ROSCA FÊMEA RP ISO 7 - ROSCA FÊMEA RP ISO 7

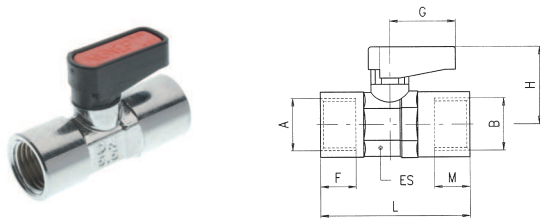

Code	A	B	(DN)	ES	F	M	L	G	H	Pack.
06300 00 001	1/8	1/8	5.5	14-15	7.4	7.4	36	19	21	10
06300 00 002	1/4	1/4	5.5	14-15	11	11	43	19	21	10
06300 00 003	3/8	3/8	8	18-19	11.4	11.4	47	19	22	10
06300 00 004	1/2	1/2	10	22-23	15	15	59	26	30.5	10
06300 00 055	3/4	3/4	14	28-30	16.3	16.3	67	50	33	5

6310

VALVOLA MASCHIO CONICO R ISO 7 - FEMMINA RP ISO 7

TAPER MALE R ISO 7 - FEMALE RP ISO 7 VALVE
 KUGELHAHN AUSSENGEW. KONISCH R ISO 7 - INNENGEW. RP ISO 7
 VANNE À BILLE, FILETAGE MÂLE R ISO 7 - FILETAGE FEMELLE RP ISO 7
 VÁLVULA MACHO CÔNICO R ISO 7 - HEMBRA RP ISO 7
 VÁLVULA ROSCA MACHO CÔNICA R ISO 7 - ROSCA FÊMEA RP ISO 7

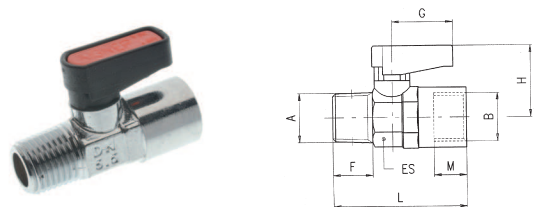

Code	A	B	(DN)	ES	F	M	L	G	H	Pack.
06310 00 001	1/8	1/8	5.5	14-15	7.4	7.4	36	19	21	10
06310 00 002	1/4	1/8	5.5	14-15	11	7.4	40.5	19	21	10
06310 00 003	1/4	1/4	5.5	14-15	11	11	43	19	21	10
06310 00 004	3/8	3/8	8	18-19	11.4	11.4	46	19	22	10
06310 00 005	1/2	1/2	10	22-23	15	15	57	26	30.5	10
06310 00 066	3/4	3/4	14	28-30	16.3	16.3	63	50	33	5

6320

VALVOLA MASCHIO CILINDRICO GA ISO 228 - FEMMINA RP ISO 7

PARALLEL MALE GA ISO 228 - FEMALE RP ISO 7 VALVE
 KUGELHAHN AUSSENGEW. ZYLINDRISCH GA ISO 228 - INNENGEW. RP ISO 7
 VANNE À BILLE, FILETAGE MÂLE GA ISO 228 - FILETAGE FEMELLE RP ISO 7
 VÁLVULA MACHO CILÍNDRICO GA ISO 228 - HEMBRA RP ISO 7
 VÁLVULA ROSCA MACHO PARALELA GA ISO 228 - FÊMEA RP ISO 7

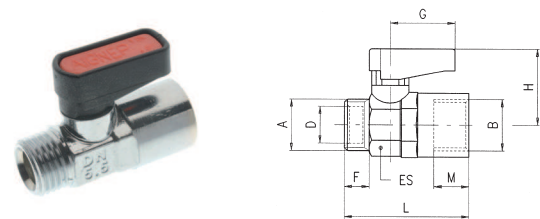

Code	A	B	(DN)	ES	D	F	M	L	G	H	Pack.
06320 00 001	1/8	1/8	5.5	14-15	6.2	7	7.4	34.5	19	21	10
06320 00 002	1/4	1/8	5.5	14-15	8.2	8	7.4	35.5	19	21	10
06320 00 003	1/4	1/4	5.5	14-15	8.2	8	11	38	19	21	10
06320 00 004	3/8	3/8	8	18-19	10.2	9	11.4	41.5	19	22	10
06320 00 005	1/2	1/2	10	22-23	15.2	10	15	50	26	30.5	10
06320 00 066	3/4	3/4	14	28-30	18.2	12	16.3	56.5	50	33	5

6330

VALVOLA MASCHIO CONICO R ISO 7 - MASCHIO CILINDRICO GA ISO 228

TAPER MALE R ISO 7 - PARALLEL MALE GA ISO 228 VALVE
 KUGELHAHN AUSSENGEW. KONISCH R ISO 7 - AUSSENGEW. ZYLINDRISCH GA ISO 228
 VANNE À BILLE, FILETAGE MÂLE R ISO 7 - FILETAGE MÂLE GA ISO 228
 VÁLVULA MACHO CÔNICO R ISO 7 - MACHO CILÍNDRICO GA ISO 228
 VÁLVULA ROSCA MACHO CÔNICA R ISO 7 - ROSCA MACHO PARALELA GA ISO 228

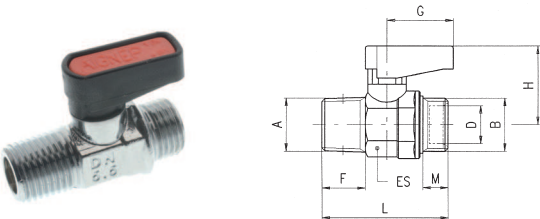

Code	A	B	(DN)	ES	D	F	M	L	G	H	Pack.
06330 00 001	1/8	1/8	5.5	14-15	6.2	7.4	7	33.5	19	21	10
06330 00 002	1/8	1/4	5.5	14-15	8.2	7.4	8	33.5	19	21	10
06330 00 003	1/4	1/8	5.5	14-15	6.2	11	7	38	19	21	10
06330 00 004	1/4	1/4	5.5	14-15	8.2	11	8	38	19	21	10
06330 00 005	3/8	3/8	8	18-19	10.2	11.4	9	41.5	19	22	10
06330 00 006	1/2	1/2	10	22-23	15.2	15	10	49	26	30.5	10
06330 00 077	3/4	3/4	14	28-30	18.2	16.3	12	55.5	50	33	5

6340

VALVOLA TUBO - FEMMINA RP ISO 7

TUBE - FEMALE RP ISO 7 VALVE
 KUGELHAHN ROHR - INNENGEW. G ISO 228
 VANNE À BILLE, TUBE - FILETAGE FEMELLE RP ISO 7
 VÁLVULA TUBO - HEMBRA RP ISO 7
 VÁLVULA TUBO - ROSCA FÊMEA RP ISO 7

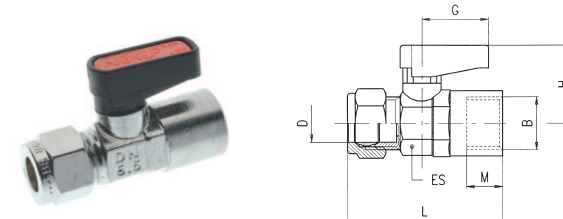

Code	D	B	(DN)	ES	M	L	G	H	Pack.
06340 00 001	6	1/8	5.5	14-15	7.4	41.5	19	21	10
06340 00 002	8	1/8	5.5	14-15	7.4	43	19	21	10
06340 00 003	8	1/4	5.5	14-15	11	46	19	21	10
06340 00 004	10	3/8	8	18-19	11.4	50.5	19	22	10
06340 00 005	12	3/8	8	18-19	11.4	51.5	19	22	10
06340 00 006	14	1/2	10	22-23	15	61.5	26	30.5	10
06340 00 007	15	1/2	10	22-23	15	61.5	26	30.5	10
06340 00 098	16	3/4	14	28-30	16.3	68	50	33	5
06340 00 099	18	3/4	14	28-30	16.3	68	50	33	5

6350

VALVOLA MASCHIO CONICO R ISO 7 - TUBO

TAPER MALE R ISO 7 - TUBE VALVE
 KUGELHAHN AUSSENGEW. KONISCH R ISO 7 - ROHR
 VANNE À BILLE, FILETAGE MÂLE R ISO 7 - TUBE
 VÁLVULA MACHO CÔNICO R ISO 7 - TUBO
 VÁLVULA ROSCA MACHO CÔNICA R ISO 7 - TUBO

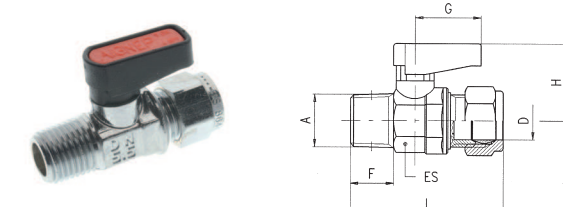

Code	A	D	(DN)	ES	F	L	G	H	Pack.
06350 00 001	1/8	6	5.5	14-15	7.4	40.5	19	21	10
06350 00 002	1/8	8	5.5	14-15	7.4	41.5	19	21	10
06350 00 003	1/4	6	5.5	14-15	11	46	19	21	10
06350 00 004	1/4	8	5.5	14-15	11	45	19	21	10
06350 00 005	3/8	10	8	18-19	11.4	50.5	19	22	10
06350 00 006	3/8	12	8	18-19	11.4	51.5	19	22	10
06350 00 007	1/2	14	10	22-23	15	59.5	26	30.5	10
06350 00 008	1/2	15	10	22-23	15	59.5	26	30.5	10
06350 00 109	3/4	16	14	28-30	16.3	67	50	33	5
06350 00 110	3/4	18	14	28-30	16.3	67	50	33	5

6400

VALVOLA FEMMINA G ISO 228 - FEMMINA G ISO 228

FEMALE G ISO 228 - FEMALE G ISO 228 VALVE
 KUGELHAHN INNENGEW. G ISO 228 - INNENGEW. G ISO 228
 VANNE À BILLE, FILETAGE FEMELLE G ISO 228 - FILETAGE FEMELLE G ISO 228
 VÁLVULA HEMBRA G ISO 228 - HEMBRA G ISO 228
 VÁLVULA ROSCA FÊMEA G ISO 228 - ROSCA FÊMEA G ISO 228

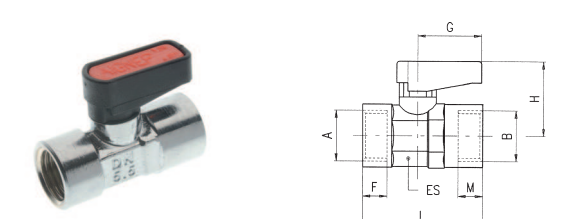

Code	A	B	(DN)	ES	F	M	L	G	H	Pack.
06400 00 001	1/8	1/8	5.5	14-15	7	7	35	19	21	10
06400 00 002	1/4	1/4	5.5	14-15	8	8	37	19	21	10
06400 00 003	3/8	3/8	8	18-19	9	9	42	19	22	10
06400 00 004	1/2	1/2	10	22-23	10	10	49	26	30.5	10
06400 00 055	3/4	3/4	14	28-30	12	12	58	50	33	5

6410

VALVOLA MASCHIO CILINDRICO GA ISO 228 - FEMMINA G ISO 228

PARALLEL MALE GA ISO 228 - FEMALE G ISO 228 VALVE
 KUGELHAHN AUSSENGEW. ZYLINDRISCH GA ISO 228 - INNENGEW. G ISO 228
 VANNE À BILLE, FILETAGE MÂLE GA ISO 228 - FILETAGE FEMELLE G ISO 228
 VÁLVULA MACHO CILÍNDRICO GA ISO 228 - HEMBRA G ISO 228
 VÁLVULA ROSCA MACHO PARALELA GA ISO 228 - ROSCA FÊMEA G ISO 228

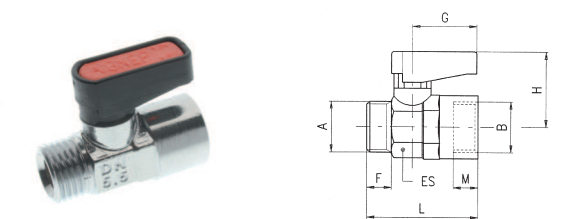

Code	A	B	(DN)	ES	F	M	L	G	H	Pack.
06410 00 001	1/8	1/8	5.5	14-15	7	7	34	19	21	10
06410 00 002	1/4	1/8	5.5	14-15	8	7	35	19	21	10
06410 00 003	1/4	1/4	5.5	14-15	8	8	35	19	21	10
06410 00 004	3/8	3/8	8	18-19	9	9	39	19	22	10
06410 00 005	1/2	1/2	10	22-23	10	10	45	26	30.5	10
06410 00 066	3/4	3/4	14	28-30	12	12	52	50	33	5

6420

VALVOLA MASCHIO CILINDRICO GA ISO 228 - MASCHIO CILINDRICO GA ISO 228
 PARALLEL MALE GA ISO 228 - PARALLEL MALE GA ISO 228 VALVE
 KUGELHAHN AUSSENGEW. ZYLINDRISCH GA ISO 228 - AUSSENGEW. ZYLINDRISCH GA ISO 228
 VANNE À BILLE, FILETAGE MÂLE GA ISO 228 - FILETAGE MÂLE GA ISO 228
 VÁLVULA MACHO CILÍNDRICO GA ISO 228 - MACHO CILÍNDRICO GA ISO 228
 VÁLVULA ROSCA MACHO PARALELA GA ISO 228 - ROSCA MACHO PARALELA GA ISO 228

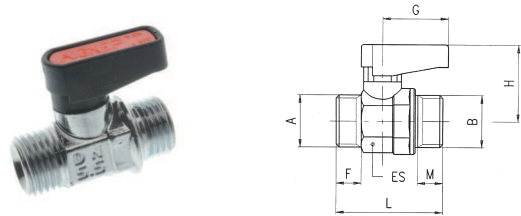

Code	A	B	DN	ES	F	M	L	G	H	Pack.
06420 00 001	1/8	1/8	5.5	14-15	7	7	32	19	21	10
06420 00 002	1/8	1/4	5.5	14-15	7	8	32	19	21	10
06420 00 003	1/4	1/4	5.5	14-15	8	8	33	19	21	10
06420 00 004	3/8	1/4	5.5	14-15	9	8	33	19	21	10
06420 00 005	3/8	3/8	8	18-19	9	9	37	19	22	10
06420 00 006	1/2	3/8	8	18-19	10	9	37	19	22	10
06420 00 007	1/2	1/2	10	22-23	10	10	42	26	30.5	10
06420 00 008	3/4	1/2	10	22-23	12	10	42	50	30.5	10
06420 00 099	3/4	3/4	14	28-30	12	12	49	50	33	5

6430

VALVOLA TUBO - FEMMINA G ISO 228
 TUBE - FEMALE G ISO 228 VALVE
 KUGELHAHN ROHR - INNENGEW. G ISO 228
 VANNE À BILLE, TUBE - FILETAGE FEMELLE G ISO 228
 VÁLVULA TUBO - HEMBRA G ISO 228
 VÁLVULA TUBO - ROSCA FÊMEA G ISO 228

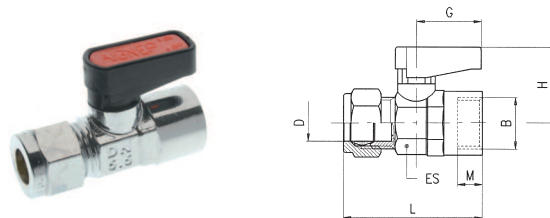

Code	D	B	DN	ES	M	L	G	H	Pack.
06430 00 001	6	1/8	5.5	14-15	7	41	19	21	10
06430 00 002	8	1/8	5.5	14-15	7	43	19	21	10
06430 00 003	8	1/4	5.5	14-15	8	43	19	21	10
06430 00 004	10	3/8	8	18-19	9	48	19	22	10
06430 00 005	12	3/8	8	18-19	9	49	19	22	10
06430 00 006	14	1/2	10	22-23	10	55.5	26	30.5	10
06430 00 007	15	1/2	10	22-23	10	55.5	26	30.5	10
06430 00 098	16	3/4	14	28-30	12	63.5	50	33	5
06430 00 099	18	3/4	14	28-30	12	63.5	50	33	5

6440

VALVOLA MASCHIO CILINDRICO GA ISO 228 - TUBO
 PARALLEL MALE GA ISO 228 - TUBE VALVE
 KUGELHAHN AUSSENGEW. ZYLINDRISCH GA ISO 228 - ROHR
 VANNE À BILLE, FILETAGE MÂLE GA ISO 228 - TUBE
 VÁLVULA MACHO CILÍNDRICO GA ISO 228 - TUBO
 VÁLVULA ROSCA MACHO PARALELA GA ISO 228 - TUBO

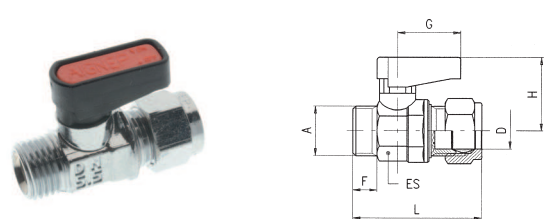

Code	A	D	DN	ES	F	L	G	H	Pack.
06440 00 001	1/8	6	5.5	14-15	7	39	19	21	10
06440 00 002	1/8	8	5.5	14-15	7	40	19	21	10
06440 00 003	1/4	6	5.5	14-15	8	40	19	21	10
06440 00 004	1/4	8	5.5	14-15	8	41	19	21	10
06440 00 005	1/4	10	5.5	14-15	8	44	19	21	10
06440 00 006	3/8	8	5.5	14-15	9	43	19	21	10
06440 00 007	3/8	10	8	18-19	9	46	19	22	10
06440 00 008	3/8	12	8	18-19	9	47	19	22	10
06440 00 009	3/8	14	8	18-19	9	50.5	19	22	10
06440 00 010	3/8	15	8	18-19	9	50.5	19	22	10
06440 00 011	1/2	10	8	18-19	10	49	19	22	10
06440 00 012	1/2	12	8	18-19	10	50	19	22	10
06440 00 013	1/2	14	10	22-23	10	52.5	26	30.5	10
06440 00 014	1/2	15	10	22-23	10	52.5	26	30.5	10
06440 00 015	3/4	14	10	22-23	12	56.5	26	30.5	10
06440 00 016	3/4	15	10	22-23	12	56.5	26	30.5	10
06440 00 197	3/4	16	14	28-30	12	60.5	50	33	5
06440 00 198	3/4	18	14	28-30	12	60.5	50	33	5

Nelle misure 1/4-8, 1/4-10, 3/8-14, 3/8-15 il dado, il bicono e il filetto A sono all'opposto della figura.
 In the sizes 1/4-8, 1/4-10, 3/8-14, 3/8-15 the nut, the double cone and the thread A are at the opposite side of the picture.
 In den Größen 1/4-8, 1/4-10, 3/8-14, 3/8-15 sind die Überwurfmutter mit dem Klemmring und das Gewinde A auf der gegenüberliegenden Seite des Bildes.
 Pour les dimensions 1/4-8, 1/4-10, 3/8-14, 3/8-15, le filetage A et le raccord sont inversés par rapport à l'image.
 En las medidas 1/4-8, 1/4-10, 3/8-14, 3/8-15 la tuerca, el bicono y la rosca A son opuestos a la figura.
 Nos tamanhos 1/4-8, 1/4-10, 3/8-14, 3/8-15 a porca, o cone duplo e a rosca A são do lado oposto ao mostrado na foto.

6450

VALVOLA TUBO - TUBO
 TUBE - TUBE VALVE
 KUGELHAHN ROHR - ROHR
 VANNE À BILLE, TUBE - TUBE
 VÁLVULA TUBO - TUBO
 VÁLVULA TUBO - TUBO

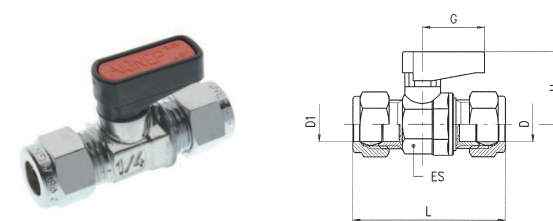

Code	D1	D	DN	ES	L	G	H	Pack.
06450 00 001	6	6	5.5	14-15	46	19	21	10
06450 00 002	6	8	5.5	14-15	48	19	21	10
06450 00 003	8	8	5.5	14-15	48	19	21	10
06450 00 004	10	8	5.5	14-15	51	19	21	10
06450 00 005	10	10	8	18-19	55	19	22	10
06450 00 006	10	12	8	18-19	56	19	22	10
06450 00 007	12	12	8	18-19	57	19	22	10
06450 00 008	14	10	8	18-19	59.5	19	22	10
06450 00 009	14	12	8	18-19	60.5	19	22	10
06450 00 010	15	10	8	18-19	59.5	19	22	10
06450 00 011	15	12	8	18-19	60.5	19	22	10
06450 00 012	14	14	10	22-23	63	26	30.5	10
06450 00 013	15	14	10	22-23	63	26	30.5	10
06450 00 014	15	15	10	22-23	63	26	30.5	10
06450 00 015	16	14	10	22-23	68	26	30.5	10
06450 00 016	16	15	10	22-23	68	26	30.5	10
06450 00 017	18	14	10	22-23	68	26	30.5	10
06450 00 018	18	15	10	22-23	68	26	30.5	10
06450 00 219	18	16	14	28-30	71	50	33	5
06450 00 220	18	18	14	28-30	71	50	33	5

6460

No Gas

VALVOLA DADO CAPETTATO - MASCHIO CONICO R ISO 7
 MILLED NUT - TAPER MALE R ISO 7 VALVE
 KUGELHAHN RÄNDELMUTTER - AUSSENGEW. KONISCH R ISO 7
 VANNE À BILLE, ECROU MOLETÉ - FILETAGE MÂLE R ISO 7
 VÁLVULA TUERCA - MACHO CÓNICO R ISO 7
 VÁLVULA PORCA RECARILHADA - ROSCA MACHO CÓNICA R ISO 7

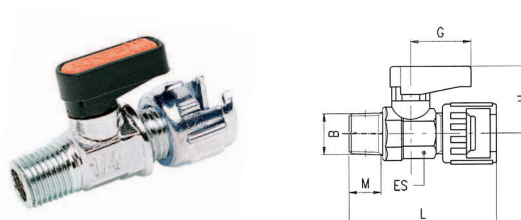

Code	B	DN	ES	M	L	G	H	Pack.
06460 00 001	1/8	5.5	14-15	7.4	44	19	21	10
06460 00 002	1/4	5.5	14-15	11	49.5	19	21	10
06460 00 003	3/8	8	18-19	11.4	50	19	21	10

6470

No Gas

VALVOLA DADO CAPETTATO - FEMMINA G ISO 228
 MILLED NUT - FEMALE G ISO 228 VALVE
 KUGELHAHN RÄNDELMUTTER - INNENGEW. G ISO 228
 VANNE À BILLE, ECROU MOLETÉ - FILETAGE FEMELLE G ISO 228
 VÁLVULA TUERCA - HEMBRA G ISO 228
 VÁLVULA PORCA RECARILHADA - ROSCA FÊMEA G ISO 228

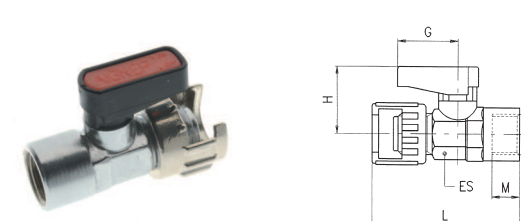

Code	B	DN	ES	M	L	G	H	Pack.
06470 00 001	1/8	5.5	14-15	7	46	19	21	10
06470 00 002	1/4	5.5	14-15	8	46	19	21	10

6490

VALVOLA CON PIEDINI D'ANCORAGGIO FEMMINA-FEMMINA
 FOOT MOUNTED FEMALE-FEMALE VALVE
 KUGELHAHN MIT INNENGEWINDE UND BEFESTIGUNGSBÜGEL
 VANNE À BILLE, FILETAGE FEMELLE, PATTES DE FIXATION
 VÁLVULA CON PIE DE ANCLAJE HEMBRA-HEMBRA
 VÁLVULA COM PÉS DE FIXAÇÃO ROSCA FÊMEA-FÊMEA

Code	A	B	DN	ES	L	F	M	G	H	H1	P	Pack.
06490 00 002	1/4	1/4	5,5	14-15	43,5	8	8	19	21	31,5	30	10
06490 00 003	3/8	3/8	8	18-19	44	9	9	19	22	38	32	10

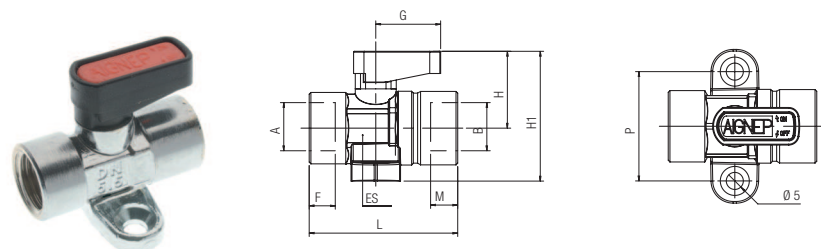

6500

VALVOLA CON PIEDINI D'ANCORAGGIO TUBO-TUBO
 FOOT MOUNTED TUBE-TUBE VALVE
 KUGELHAHN MIT BEFESTIGUNGSFLANSCH ROHR-ROHR
 VANNE À BILLE, TUBE-TUBE, AVEC PLAQUE DE FIXATION
 VÁLVULA CON PIE DE ANCLAJE TUBO - TUBO
 VÁLVULA COM PÉS DE FIXAÇÃO TUBO-TUBO

Code	D	D1	DN	ES	L	H	H1	G	P	Pack.
06500 00 001	8	8	5.5	14-15	50	21	32	19	30	10

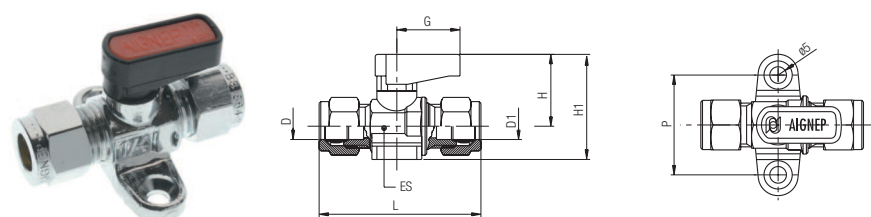

6540

VALVOLA A L MASCHIO CILINDRICO GA ISO 228-MASCHIO CONICO R ISO 7
 ELBOW PARALLEL MALE GA ISO 228-TAPER MALE R ISO 7 VALVE
 WINKELKUGELHAHN AUSSENGEW. ZYLINDRISCH GA ISO 228 - AUSSENGEW. KONISCH R ISO 7
 VANNE À BILLE EN EQUERRE, FILETAGE MÂLE R ISO 7 - FILETAGE MÂLE GA ISO 228
 VÁLVULA A L MACHO CILÍNDRICO GA ISO 228 - MACHO CÓNICO R ISO 7
 VÁLVULA EM "L" ROSCA MACHO PARALELA GA ISO 228-ROSCA MACHO CÓNICA R ISO 7

Code	A	B	DN	ES	ES1	L	H	H1	G	Pack.
06540 00 001	1/4	1/4	5.5	14-15	17	48	21	17	19	10

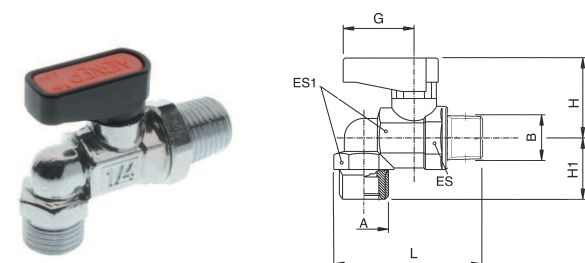

6560

VALVOLA CON ATTACCHI TUBO AUTOMATICI
 PUSH-IN CONNECTIONS VALVE
 KUGELHAHN MIT STECKANSCHLUSS ROHR - ROHR
 VANNE À BILLE AVEC RACCORDS INSTANTANÉS
 VÁLVULA PARA TUBO AUTOMÁTICO
 VÁLVULA COM ENGATE RÁPIDO PARA TUBO

No Gas

Code	Tube	Tube	DN	ES	L	G	H	Pack.
06560 00 001	4	4	3	14-15	44	19	21	10
06560 00 002	6	6	5	14-15	48	19	21	10
06560 00 003	8	8	5.5	14-15	48	19	21	10
06560 00 075	10	10	8	18-19	58.5	19	22	10
06560 00 076	12	12	10	22-23	66	26	30.5	10

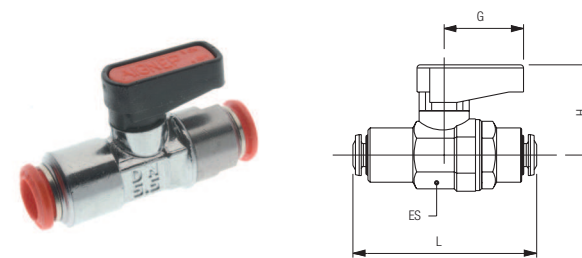

6570

VALVOLA MASCHIO CONICO R ISO 7 - ATTACCO TUBO AUTOMATICO
 TAPER MALE R ISO 7 - PUSH-FIT CONNECTIONS VALVE
 KUGELHAHN AUSSENGEW. KONISCH R ISO 7 - ROHR STECKANSCHLUSS
 VANNE À BILLE, FILETAGE MÂLE R ISO 7 - RACCORD INSTANTANÉ
 VÁLVULA A ESFERA MACHO - TUBO AUTOMÁTICO
 VÁLVULA ROSCA MACHO CÓNICA R ISO 7 - ENGATE RÁPIDO PARA TUBO

No Gas

Code	A	Tube	DN	F	ES	L	C	H	Pack.
06570 00 001	1/8	4	3	8.5	14-15	35	19	21	10
06570 00 002	1/8	6	5	8.5	14-15	40	19	21	10
06570 00 004	1/8	8	5.5	8.5	14-15	41.5	19	21	10
06570 00 003	1/4	6	5	12.5	14-15	38.5	19	21	10
06570 00 005	1/4	8	5.5	12.5	14-15	45.5	19	22	10

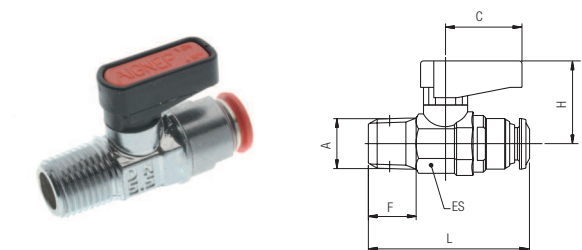

6600

VALVOLA CON FORO DI SFIATO FEMMINA G ISO 228
 EXHAUST HOLE FEMALE G ISO 228 - FEMALE G ISO 228 VALVE
 KUGELHAHN MIT ENTLÜFTUNGSBOHRUNG INNENGEW. G ISO 228
 VANNE À BILLE À PURGE, FILETAGE FEMELLE G ISO 228 - FILETAGE FEMELLE G ISO 228
 VÁLVULA HEMBRA ISO 228 CON ESCAPE ATMÓSFERA
 VÁLVULA COM FURO DE ESCAPE E ROSCA FÊMEA G ISO 228

No Gas

Code	A	B	DN	ES	F	M	L	G	H	S	Pack.
06600 00 001	1/8	1/8	5.5	14-15	7	7	35	19	21	2.5	10
06600 00 002	1/4	1/4	5.5	14-15	8	8	37	19	21	2.5	10
06600 00 003	3/8	3/8	8	18-19	9	9	42	19	22	3	10

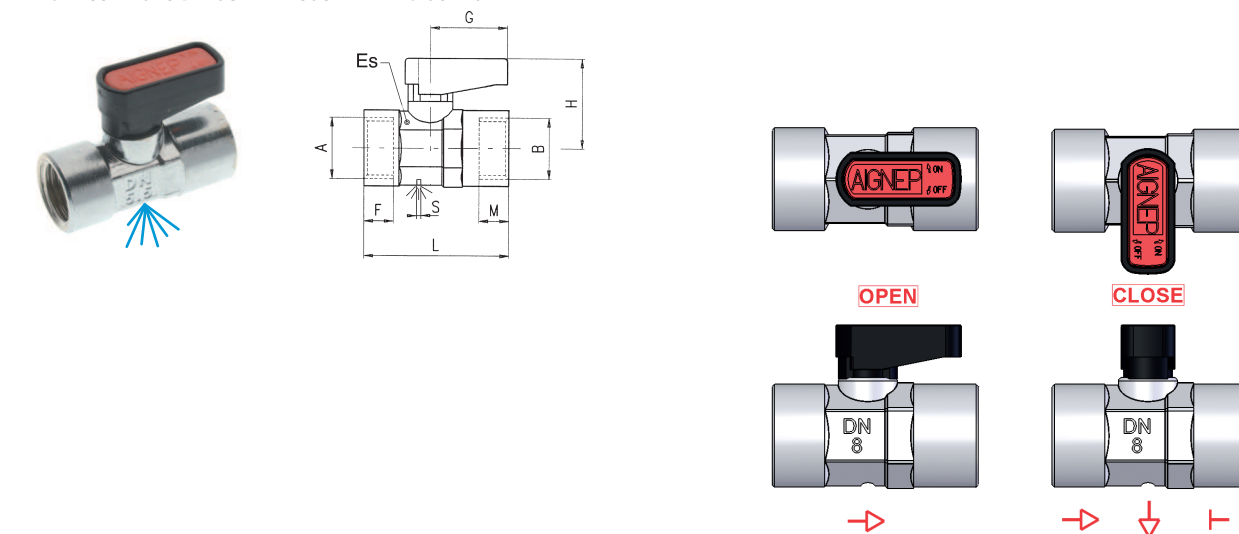

86300

VALVOLA FEMMINA NPTF - FEMMINA NPTF

NPTF FEMALE - NPTF FEMALE VALVE
KUGELHAHN INNENGEW. NPTF - INNENGEW. NPTF
VANNE À BILLE, FILETAGE FEMELLE NPTF - FILETAGE FEMELLE NPTF
VÁLVULA HEMBRA NPTF - HEMBRA NPTF
VÁLVULA ROSCA FÊMEA NPTF - ROSCA FÊMEA NPTF

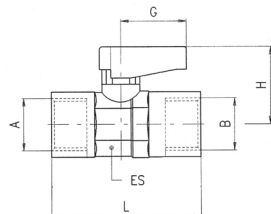

Code	A	B	DN	ES	L	G	H	Pack.
86300 00 001	1/8	1/8	5.5	14-15	37,5	19	21	10
86300 00 002	1/4	1/4	5.5	14-15	46	19	21	10
86300 00 003	3/8	3/8	8	18-19	48,5	19	22	10
86300 00 004	1/2	1/2	10	22-23	62	26	30,5	10

86310

VALVOLA MASCHIO NPTF - FEMMINA NPTF

TAPER NPTF MALE - NPTF FEMALE VALVE
KUGELHAHN AUSSENGEW. NPTF KONISCH - INNENGEW. NPTF
VANNE À BILLE, FILETAGE MÂLE NPTF - FILETAGE FEMELLE NPTF
VÁLVULA MACHO NPTF - HEMBRA NPTF
VÁLVULA ROSCA MACHO NPTF - ROSCA FÊMEA NPTF

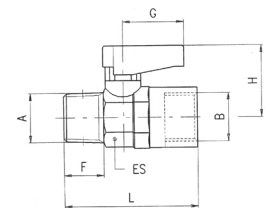

Code	A	B	DN	ES	F	L	G	H	Pack.
86310 00 001	1/8	1/8	5.5	14-15	8,5	37,5	19	21	10
86310 00 002	1/4	1/4	5.5	14-15	13	46	19	21	10
86310 00 003	3/8	3/8	8	18-19	13	48,5	19	22	10
86310 00 004	1/2	1/2	10	22-23	17	62	26	30,5	10

SERIE GHINOX

MINIVALVOLE A SFERA IN ACCIAIO INOX AISI 316 L
MINIBALLVALVE IN STAINLESS STEEL AISI 316 L
KUGELHÄHNE AISI 316 L
VANNES À BILLE EN ACIER INOXYDABLE AISI 316L
MINI VÁLVULAS A ESFERA EN ACERO INOX AISI 316L
MINI VÁLVULAS DE ESFERA EM AÇO-INOX AISI 316L



CARATTERISTICHE TECNICHE
TECHNICAL CHARACTERISTICS
TECHNISCHE ANGABEN
CARACTÉRISTIQUES TECHNIQUES
CARACTERÍSTICAS TÉCNICAS
CARACTERÍSTICAS TÉCNICAS



Norma di Riferimento

Reference Standard

Entspricht Der Norm

Conforme à La Norme

Normativa de Referencia

Norma de Referência

1907/2006
REACH ✓

2011/65/CE
RoHS ✓

97/23/CE
(PED)

SILICON
FREE

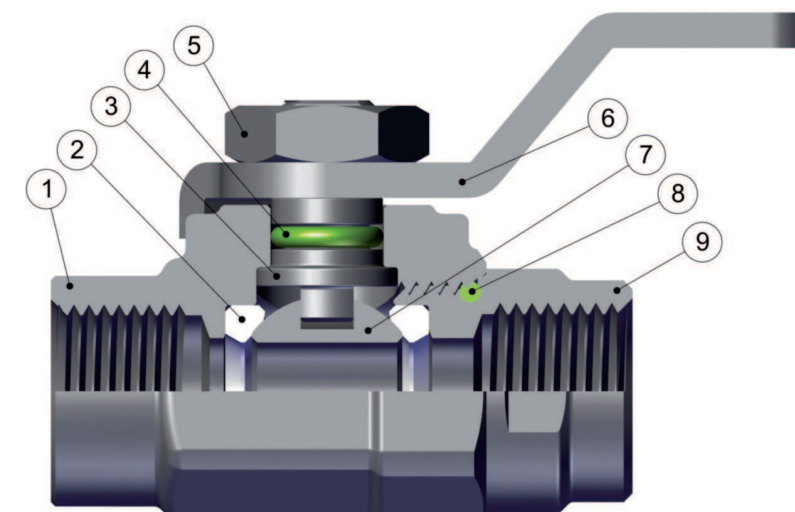

Materiali e Componenti	IT
1 Corpo in acciaio inox AISI 316L	
2 Guarnizione sede sfera in PTFE	
3 Albero in acciaio inox AISI316L	
4 Guarnizione O-RING in FKM	
5 Dado esagonale in acciaio inox AISI316L	
6 Leva di comando in acciaio inox AISI316L	
7 Sfera in acciaio inox AISI316L	
8 Guarnizione O-RING in FKM	
9 Raccordo in acciaio inox AISI316L	

Component Parts and Materials	GB
1 Stainless steel AISI 316L Body	
2 PTFE Seats	
3 Stainless steel AISI316L Spindle 4 FKM Seal O-RING	
4 FKM Seal O-RING	
5 Stainless steel AISI316L Hex Nut 6 Stainless steel AISI316L Spindle	
6 Stainless steel AISI316L Spindle	
7 Stainless steel AISI316L Ball 8 FKM Seal O-RING	
8 FKM Seal O-RING	
9 Stainless steel AISI316L Fitting	

Komponenten und Materialien	DE
1 Körper inox AISI 316L	
2 Kugelsitzdichtung PTFE	
3 Spindel inox AISI316L	
4 O-RING FKM	
5 Mutter inox AISI316L	
6 Handgriff inox AISI316L	
7 Kugel inox AISI316L	
8 O-RING FKM	
9 Gewindeinsatz inox AISI316L	

Matériels et Composants	FR
1 Corps: acier inoxydable AISI 316L	
2 Joints de siège: PTFE	
3 Entraîneur: acier inoxydable AISI316L	
4 Joint torique: FKM	
5 Ecrou: acier inoxydable AISI316L	
6 Manette: acier inoxydable AISI316L	
7 Bille: acier inoxydable AISI316L	
8 Joint torique: FKM	
9 Corps: acier inoxydable AISI316L	

Materiales y Componentes	ES
1 Cuerpo en acero inox AISI 316L	
2 Junta sede esfera en PTFE	
3 Eje en acero inox AISI316L	
4 Junta tórica en FKM	
5 Tuerca hexagonal en acero inox AISI316L	
6 Maneta de mando en acero inox AISI316L	
7 Esfera en acero inox AISI316L	
8 Junta tórica en FKM	
9 Racor en acero inox AISI316L	

Materiais e Componentes	PT
1 Corpo em aço-inox AISI 316L	
2 Vedação da sede da esfera em PTFE	
3 Eixo em aço-inox AISI316L	
4 O-ring de Vedação em FKM	
5 Porca Sextavada em aço-inox AISI316L	
6 Haste de comando em aço-inox AISI316L	
7 Esfera em aço-inox AISI316L	
8 O-ring de Vedação em FKM	
9 Conexão em aço-inox AISI316L	



Pressioni

Pressures

Druckbereich

Pressions

Presiones

Pressões

- 0.99 bar (-0.099 MPa)

40 bar (4 MPa)



Filettatura

Gas conforme ISO 7.1, BS 21, DIN 2999

Threads

Gas in conformity with ISO7.1, BS 21, DIN 2999.

Gewindearten

Gewinde nach Norm ISO 7.1, BS 21, DIN 2999

Filetages

Filetage conforme: ISO7.1, BS 21, DIN 2999.

Roscas

Gas conforme ISO 7.1, BS 21, DIN 2999

Roscas

Gas conforme ISO 7.1, BS 21, DIN 2999



Fluidi compatibili

Aria compressa / Vuoto / Acqua / Oli
Fluidi per Industria alimentare e chimica compatibili con i componenti.

Fluids

Compressed air / Vacuum / Water / Oils
Fluid for food and chemical industry compatible with components.

Geeignete Medien

Druckluft / Vakuum / Wasser / Öl
Medien für die Lebensmittel- und chemische Industrie, die beständig mit den Verschraubungen sind.

Fluides compatibles

Air comprimé / Vide / Eau / Huile
Fluides alimentaires et chimiques compatibles avec les matériaux constituants.

Fluidos compatibles

Aire comprimido / Vacío / Agua / Aceite
Fluidos para industria alimentaria y química compatibles con los componentes.

Fluidos compatíveis

Ar comprimido / Vácuo / Água / Óleos
Fluidos para indústria alimentícia e química compatíveis com os componentes.



Temperatura minima - 15 °C

Minimum temperature
Temperatur minimum
Température minimale
Temperatura mínima
Temperatura mínima

Temperatura massima in continuo + 150 °C

Maximum temperature in continuous
Temperatur maximum kontinuierlich
Température maximale continue
Temperatura máxima en continuo
Temperatura máxima em contínuo

Temperatura massima per breve durata + 180 °C

Maximum temperature for short term
Temperatur maximum für kurzfristig
Température maximale à court terme
Temperatura máxima de corta duración
Temperatura máxima em curta duração

66300

VALVOLA FEMMINA RP ISO 7 - FEMMINA RP ISO 7

FEMALE RP ISO 7 - FEMALE RP ISO 7 VALVE
KUGELHAHN INNENGEW. RP ISO 7 - INNENGEW. RP ISO 7
VANNE À BILLE, FILETAGE FEMELLE RP ISO 7 - FILETAGE FEMELLE RP ISO 7
VÁLVULA HEMBRA RP ISO 7 - HEMBRA RP ISO 7
VÁLVULA FÊMEA RP ISO 7 - FÊMEA RP ISO 7



Code	A	B	DN	CH	F	M	L	G	H	Pack.
66300 00 001	1/8	1/8	5,5	14-15	8,5	8,5	33	28	21,5	2
66300 00 002	1/4	1/4	5,5	16-17	12,5	12,5	43	28	21,5	2

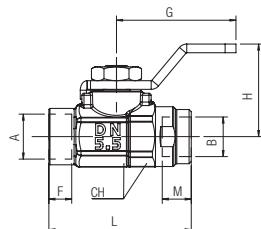

66310

VALVOLA MASCHIO CONICO R ISO 7 - FEMMINA RP ISO 7

TAPER MALE R ISO 7 - FEMALE RP ISO 7 VALVE
KUGELHAHN AUSSENGEW. KONISCH R ISO 7 - INNENGEW. RP ISO 7
VANNE À BILLE, FILETAGE MÂLE R ISO 7 - FILETAGE FEMELLE RP ISO 7
VÁLVULA MACHO CÓNICO R ISO 7 - HEMBRA RP ISO 7
VÁLVULA MACHO CÓNICA R ISO 7 - FÊMEA RP ISO 7



Code	A	B	DN	CH	F	M	L	G	H	Pack.
66310 00 001	1/8	1/8	5,5	14-15	8,5	8,5	35	28	21,5	2
66310 00 002	1/4	1/4	5,5	16-17	12,5	12,5	44,5	28	21,5	2

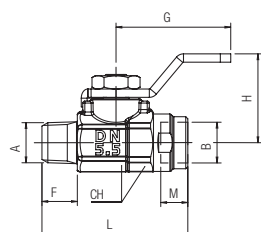

MINIVALVOLA A SFERA A 2-3 VIE

2-3 WAYS MINIBALLVALVE
DREIWEGKUGELHAHN
VANNE À BILLE 2-3 VOIES
MINI-VÁLVULA DE ESFERA 2-3 VÍAS
MINI-VÁLVULA DE ESFERA DE 2-3 VIAS



CARATTERISTICHE TECNICHE

TECHNICAL CHARACTERISTICS
TECHNISCHE ANGABEN
CARACTÉRISTIQUES TECHNIQUES
CARACTERÍSTICAS TÉCNICAS
CARACTERÍSTICAS TÉCNICAS



Norma di Riferimento

Reference Standard
Entspricht Der Norm
Conforme à La Norme
Normativa de Referencia
Norma de Referência

1907/2006 REACH ✓	2011/65/CE RoHS ✓
97/23/CE (PED)	SILICON FREE

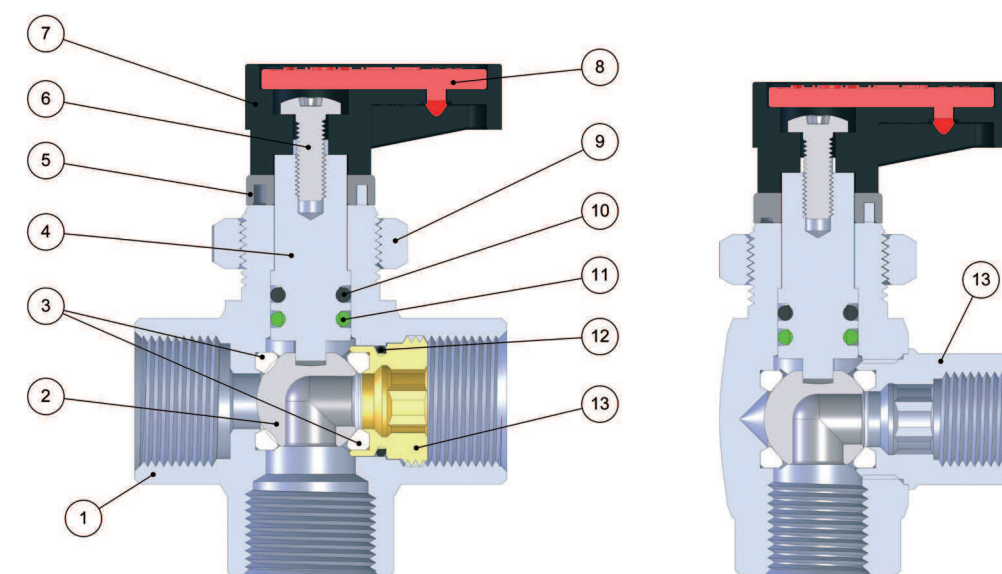

FKM A RICHIESTA
IF REQUESTED FKM
FKM AUF ANFRAGE
FKM SUR DEMANDE
FKM BAJO PEDIDO
FKM SOB ENCOMENDA

IT	Component Parts and Materials	GB	Komponenten und Materialien	DE	
1	Corpo in Ottone cromato	1	Chrome Nickel-plated Brass Body	1	Körper Messing verchromt
2	Sfera in Ottone cromato	2	Chrome Nickel-plated Brass Ball	2	Kugel Messing verchromt
3	Guarnizione sede sfera in PTFE	3	PTFE Seat	3	Kugelsitzdichtung PTFE
4	Albero in Ottone cromato	4	Chrome Nickel-plated Brass Spindle	4	Spindel Messing verchromt
5	Fermo Maniglia	5	Stop Handle	5	Anschlag
6	Vite in acciaio	6	Steel Screw	6	Schraube Stahl
7	Maniglietta in PA66 Caricato vetro	7	PA66 Glass reinforced Handle	7	Handgriff PA66 Glasfaser verstärkt
8	Piastrina in Resina Acetalica	8	Acetalic resin Plate	8	Griffplatte Acetal
9	Ghiera per passaparete	9	Bulkhead nut	9	Mutter Messing Vernickelt
10	Guarnizione O-RING in NBR	10	NBR Seal O-RING	10	O-RING in NBR
11	Guarnizione O-RING in FKM	11	FKM Seal O-RING	11	O-RING in FKM
12	Guarnizione O-RING in NBR	12	NBR Seal O-RING	12	O-RING in NBR
13	Ghiera o raccordo in Ottone	13	Brass Fitting	13	Körper Messing verchromt

FR	Materiales y Componentes	ES	Materiais e Componentes	PT	
1	Corps: laiton chromé	1	Cuerpo en latón cromado	1	Corpo em latão cromado
2	Bille: laiton chromé	2	Esfera en latón cromado	2	Esfera em latão cromado
3	Joint de siège: PTFE	3	Junta de asiento esfera en PTFE	3	Vedação sede da esfera em PTFE
4	Entraîneur: laiton chromé	4	Eje en latón cromado	4	Árvore em latão cromado
5	Butée	5	Base Maneta	5	Fixador de manopla
6	Vis: acier	6	Tornillo en acero	6	Parafuso em aço
7	Manette: PA66 chargé en fibre de verre	7	Maneta en PA66 fibra de vidrio	7	Manopla em PA66
8	Plaquette de manette: résine acétal	8	Plaqueta em resina acetálica	8	Plaqueta em resina acetálica
9	Ecrou: laiton Ni	9	Tuerca para pasatabiques	9	Porca de fixação passa-muro
10	Joint torique NBR	10	Junta O-RING en NBR	10	Vedação O-RING in NBR
11	Joint torique FKM	11	Junta O-RING en FKM	11	Vedação O-RING em FKM
12	Joint torique NBR	12	Junta O-RING en NBR	12	Vedação O-RING em NBR
13	Corps: laiton chromé	13	Tuerca o racor en latón	13	Proca e conexão em Latão



Pressioni

- Pressures
- Druckbereich
- Pressions
- Presiones
- Pressões

-0.99 (-0.099 MPa)
20 bar (2 MPa)



Temperature

- Temperatures
- Temperatur
- Températures
- Temperaturas
- Temperaturas

- 20 °C
+ 80 °C

FKM
- 15 °C
+ 130 °C



Fluidi compatibili

Aria compressa / Acqua / Oli
1ª e 2ª famiglia di gas a media pressione.
3ª famiglia di gas a bassa pressione.

Fluids

Compressed air / Water / Oils
1st and 2nd family gases at medium pressure.
3rd family gases at low pressure.

Geeignete Medien

Druckluft / Wasser / Oel
1. und 2. Familie von Gasen für Mitteldruck.
3. Familie von Gasen für Niederdruck.

Fluides compatibles

Air comprimé / Eau / Huile
Famille 1 et 2 des gazes à moyenne pression.
Famille 3 des gazes à base pression.

Fluidos compatibles

Aire comprimido / Agua / Aceite
1ª y 2ª familia de gases a media presión.
3ª familia de gas a baja presión.

Fluidos compatíveis

Ar comprimido / Água / Óleos
1ª e 2ª família de gás a média pressão.
3ª família de gás a baixa pressão.



Filettatura	IT	Threads	GB	Gewindearten	DE
Gas conforme ISO 7.1, BS 21, DIN 2999. Gas cilíndrica conforme ISO 228 Classe A.		Gas in conformity with ISO 7.1, BS 21, DIN 2999. Parallel gas in conformity with ISO 228 Class A.		Gewinde nach Norm ISO 7.1, BS 21, DIN 2999. Zylindrisches Gewinde nach Norm ISO 228 Classe A.	
Filetages	FR	Roscas	ES	Roscas	PT
Filetage conforme: ISO 7.1, BS 21, DIN 2999. Filetage cylíndrique conforme: ISO 228 Classe A.		Gas conforme ISO 7.1, BS 21, DIN 2999. Gas cilíndrica conforme ISO 228 Classe A.		Gas conforme ISO 7.1, BS 21, DIN 2999. Gas paralela conforme ISO 228 Classe A.	

6700

No Gas

VALVOLA TRE VIE A L FEMMINA G ISO 228

3 WAYS VALVE "L" FEMALE G ISO 228
DREIWEGEKUGELHAHN INNENGEW. G ISO 228
VANNE À BILLE 3 VOIES FILETAGE FEMELLE G ISO 228
VÁLVULA A 3 VIAS HEMBRA G ISO 228
VÁLVULA DE TRÊS VIAS ROSCA FÊMEA G ISO 228

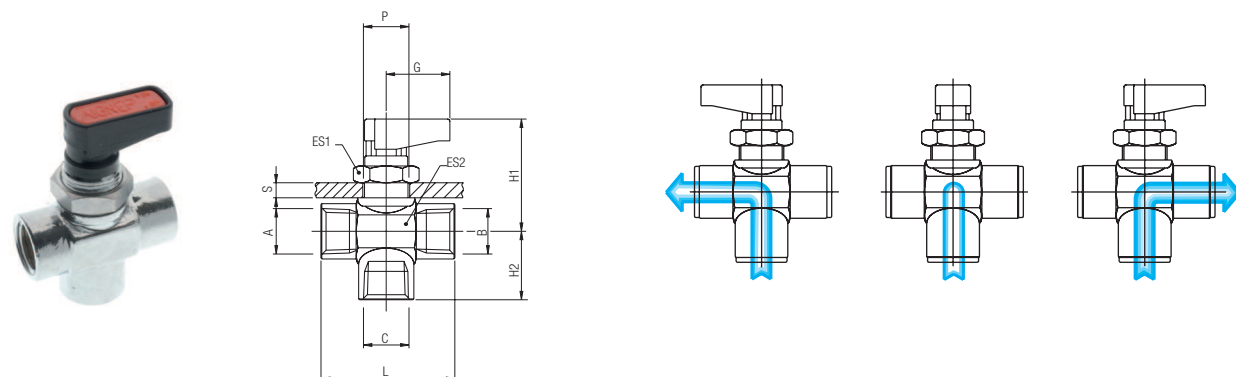

Code	A	B	C	DN	ES1	ES2	L	G	H1	H2	S max	P	Pack.
06700 00 001	1/8	1/8	1/8	5	17	17	35	19	33.5	15.5	4.5	14.5	10
06700 00 002	1/4	1/4	1/4	5	17	17	37	19	33.5	17.5	4.5	14.5	10
06700 00 003	3/8	3/8	3/8	7	17	21	42	19	35	19.5	4.5	14.5	10

6710

No Gas

VALVOLA TRE VIE A T FEMMINA G ISO 228

3 WAYS VALVE "T" FEMALE G ISO 228
DREIWEGEKUGELHAHN INNENGEW. G ISO 228
VANNE À BILLE 3 VOIES FILETAGE FEMELLE G ISO 228
VÁLVULA A 3 VIAS HEMBRA G ISO 228
VÁLVULA DE TRÊS VIAS ROSCA FÊMEA G ISO 228

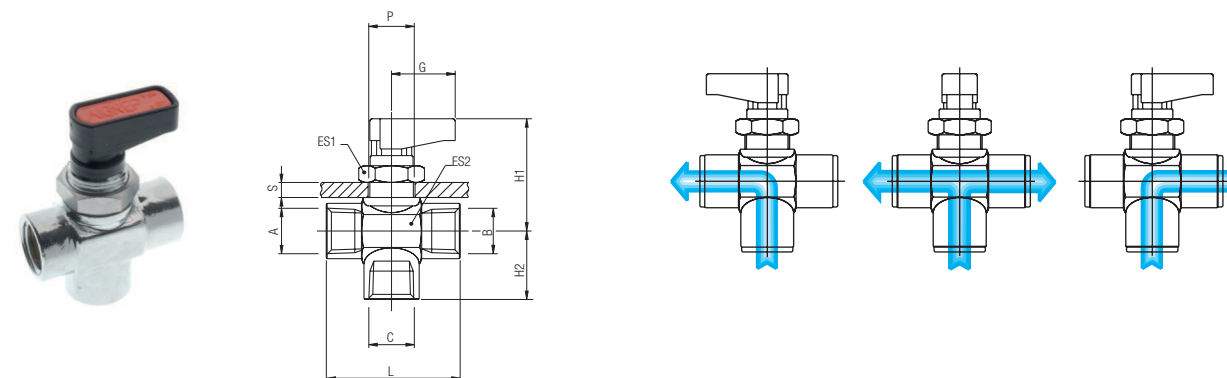

Code	A	B	C	DN	ES1	ES2	L	G	H1	H2	S max	P	Pack.
06710 00 001	1/8	1/8	1/8	5	17	17	35	19	33.5	15.5	4.5	14.5	10
06710 00 002	1/4	1/4	1/4	5	17	17	37	19	33.5	17.5	4.5	14.5	10
06710 00 003	3/8	3/8	3/8	7	17	21	42	19	35	19.5	4.5	14.5	10

6720

No Gas

VALVOLA A L FEMMINA G ISO 228

VALVE "L" FEMALE G ISO 228
WINKELKUGELHAHN INNENGEW. G ISO 228
VANNE À BILLE EN EQUERRE, FILETAGE MÂLE GA ISO 228
VÁLVULA A L HEMBRA G ISO 228
VÁLVULA EM L ROSCA FÊMEA G ISO 228

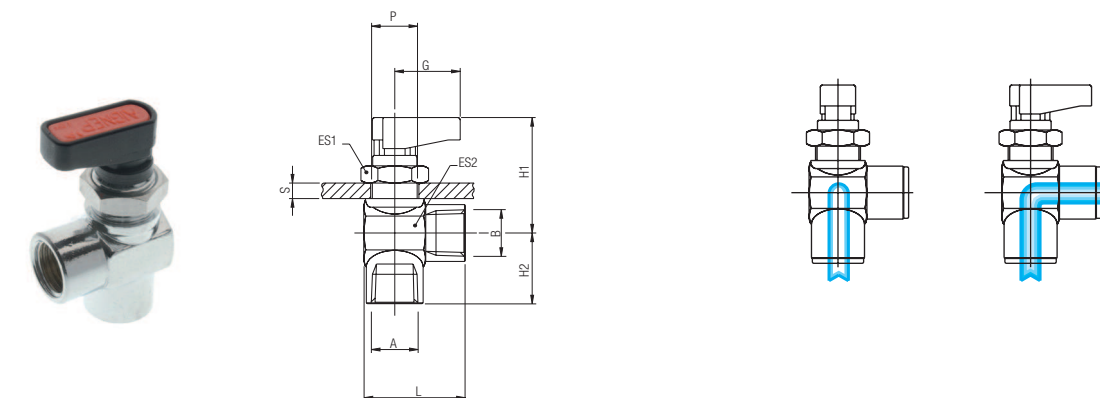

Code	A	B	DN	ES1	ES2	L	G	H1	H2	S max	P	Pack.
06720 00 001	1/8	1/8	5	17	17	28.5	19	33.5	15.5	4.5	14.5	10
06720 00 002	1/4	1/4	5	17	17	28.5	19	33.5	17.5	4.5	14.5	10
06720 00 003	3/8	3/8	7	17	21	31	19	35	19.5	4.5	14.5	10

6900

MANIGLIA CORTA
SHORT HANDLE
HANDGRIFF KURZ
MANETTE COURT
MANETA CORTA
MANOPLA CURTA

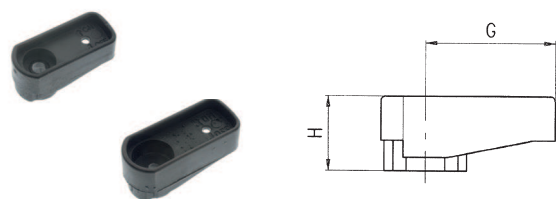

Code	Type	G	H	Pack.
06900 A0 30 00 00	A	19	11	20
06900 B0 30 00 00	B	26	15	20

A = Per valvole da 1/8 - 1/4 - 3/8.
For valves of 1/8 - 1/4 - 3/8.
Für Kugelhähne mit 1/8 - 1/4 - 3/8.
Pour vanes 1/8 - 1/4 - 3/8.
Para válvulas de 1/8 - 1/4 - 3/8.
Para válvulas de 1/8 - 1/4 - 3/8.

B = Per valvole da 1/2 - 3/4.
For valves of 1/2 - 3/4.
Für Kugelhähne mit 1/2 - 3/4.
Pour vanes of 1/2 - 3/4.
Para válvulas de 1/2 - 3/4.
Para válvulas de 1/2 - 3/4.

Maniglia CORTA standard per valvola da 1/8-1/4-3/8-1/2.
Standard SHORT Handle for Valve 1/8-1/4-3/8-1/2.
Handgriff KURZ Standard für 1/8-1/4-3/8-1/2.
Manette COURTE en standard pour 1/8-1/4-3/8-1/2.
Maneta CORTA estándar para válvula de 1/8-1/4-3/8-1/2.
Manopla CURTA standard para válvula de 1/8-1/4-3/8-1/2.

6910

MANIGLIA LUNGA
LONG HANDLE
HANDGRIFF LANG
MANETTE RALLONGÉE
MANETA LARGA
MANOPLA LONGA

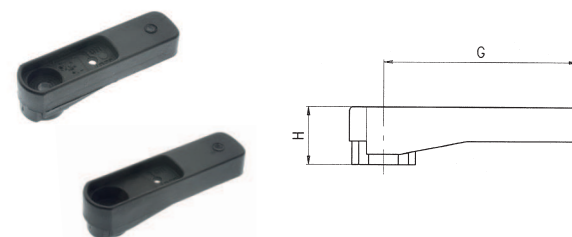

Code	Type	G	H	Pack.
06910 A0 30 00 00	A	35	11	20
06910 B0 30 00 00	B	50	15	20

A = Per valvole da 1/8 - 1/4 - 3/8.
For valves of 1/8 - 1/4 - 3/8.
Für Kugelhähne mit 1/8 - 1/4 - 3/8.
Pour vanes 1/8 - 1/4 - 3/8.
Para válvulas de 1/8 - 1/4 - 3/8.

B = Per valvole da 1/2 - 3/4.
For valves of 1/2 - 3/4.
Für Kugelhähne mit 1/2 - 3/4.
Pour vanes of 1/2 - 3/4.
Para válvulas de 1/2 - 3/4.

Maniglia LUNGA standard per valvola da 3/4.
standard LONG Handle for Valve 3/4.
Handgriff LANG Standard für 3/4.
Manette RALLONGÉE en standard pour 3/4.
Maneta LARGA estándar para válvula de 3/4.
Manopla LONGA standard para válvula de 3/4.

PROLUNGA ALBERO DI COMANDO

SPINDLE EXTENSION
VERLÄNGERTE SCHALTWELLE
RALLONGE POUR ENTRAÎNEUR
PROLONGACIÓN DEL EJE DE MANDO
PROLONGAMENTO DO EIXO DE COMANDO



1907/2006
REACH ✓

2011/65/CE
RoHS ✓

97/23/CE
(PED)

BS EN
331:1998

SILICON
FREE

IT Tutti i modelli di valvola a sfera di questa serie possono essere forniti con asta di manovra prolungata (vedi fig). **GB** All the valves "GHILUX" can be supplied with a spindle extension (see the picture).

DE Alle Modelle dieser Kugelhahn Serie können mit verlängerter Schaltwelle (siehe Abbildung) geliefert werden. **FR** Les vannes à bille "GHILUX" peuvent être commandées avec une rallonge pour entraîneur (voir photo).

ES Todos los modelos de válvulas a esfera de esta serie se pueden fabricar con el eje de maniobra prolongado (ver figura). **PT** Todos os modelos de válvula de esfera desta série podem ser fornecidos com haste de acionamento



6915

PROLUNGA ALBERO DI COMANDO (CON MANIGLIA LUNGA, VITE)
SPINDLE EXTENSION (WITH LONG HANDLE, SCREW)
VERLÄNGERTE SCHALTWELLE (MIT LANGEM GRIFF UND SCHRAUBE)
RALLONGE POUR ENTRAÎNEUR (AVEC MANETTE RALLONGÉE ET VIS)
PROLONGACIÓN EJE DE MANDO (CON MANETA LARGA, TORNILLO Y PLAQUETA)
PROLONGAMENTO DE EIXO DE COMANDO (COM MANOPLA LONGA, PAREFUSOS)

Code	Type	Valve size	L	Pack.
06915 00 001	A	1/8	58	10
		1/4	58	
		3/8	59	
06915 00 002	B	1/2	68	10
		3/4	70	

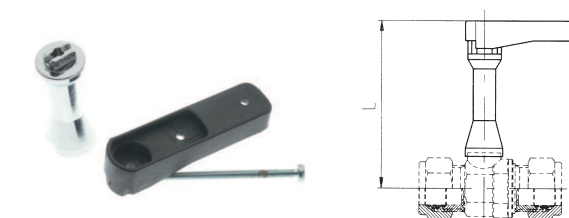

6920

PIASTRINA COLORATA
COLOURED PLATE
HANDGRIFF FARBEN
PLAQUETTE DE COULEURS
PLAQUETA COLOREADA
PLAQUETA COLORIDA

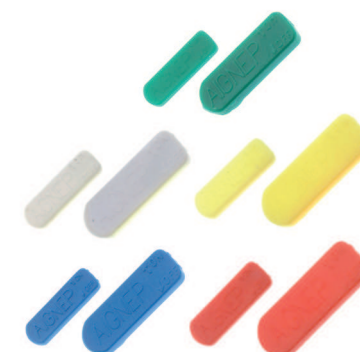

Code	Type	Color	Pack.
06920 A0 30 00 RO	A	Red	100
06920 B0 30 00 RO	B	Red	100
06920 A0 30 00 GI	A	Yellow	100
06920 B0 30 00 GI	B	Yellow	100
06920 A0 30 00 BL	A	Blue	100
06920 B0 30 00 BL	B	Blue	100
06920 A0 30 00 VE	A	Green	100
06920 B0 30 00 VE	B	Green	100
06920 A0 30 00 BN	A	White	100
06920 B0 30 00 BN	B	White	100

6680

DADO
NUT
ÜBERWURFMUTTER
ECROU
TUERCA
PORCA

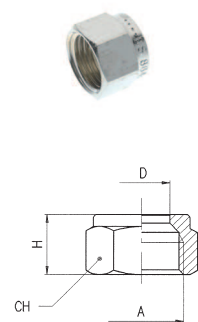

Code	D	A	H	CH	Pack.
06680 00 01 BS CT	6	1/8	11	12	100
06680 00 01 BJ CT	8	1/4	12	15	100
06680 00 01 CG CT	10	3/8	13	19	100
06680 00 01 CL CT	12	3/8	14	19	100
06680 00 01 DB CT	14	1/2	15	24	100
06680 00 01 CP CT	15	1/2	15	24	100
06680 00 01 CS CT	16	3/4	17	30	100
06680 00 01 CX CT	18	3/4	17	30	100

10740

OGIVA OTTONE
BRASS OLIVE
KLEMMRING MESSING
BAGUE LAITON
BICONO LATÓN
BUCHA DE LATÃO

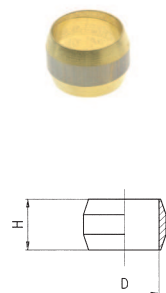

Code	D	H	Pack.
10740 00 02 X4 00	6	6.5	50
10740 00 02 X7 00	8	6.5	50
10740 00 02 X9 00	10	7.5	50
10740 00 02 Y1 00	12	8	50
10740 00 02 Y4 00	15	9	20
10740 00 02 Y7 00	18	10	20

10741

OGIVA OTTONE
BRASS OLIVE
KLEMMRING MESSING
BAGUE LAITON
BICONO LATÓN
BUCHA DE LATÃO

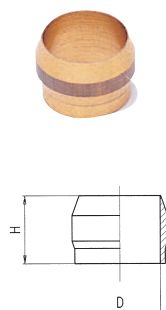

Code	D	H	Pack.
10741 00 01 Y3 00	14	12	50
10741 00 01 Y5 00	16	13.5	50

10760

OGIVA PTFE
PTFE OLIVE
KLEMMRING PTFE
BAGUE PTFE
BICONO PTFE
BUCHA DE PTFE

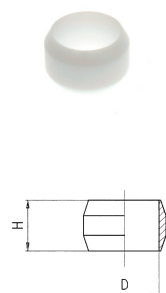

Code	D	H	Pack.
10760 00 28 X4 00	6	6.5	50
10760 00 28 X7 00	8	6.5	50
10760 00 28 X9 00	10	7.5	50
10760 00 28 Y1 00	12	8	50
10760 00 28 Y4 00	15	9	50
10760 00 28 Y7 00	18	10	50

10761

OGIVA PTFE
PTFE OLIVE
KLEMMRING PTFE
BAGUE PTFE
BICONO PTFE
BUCHA DE PTFE

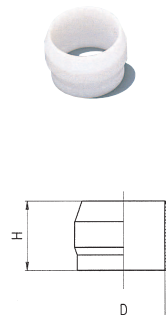

Code	D	H	Pack.
10761 00 28 Y3 00	14	12	50
10761 00 28 Y5 00	16	13.5	50

MINIVALVOLE A SFERA

MINIBALL VALVES
MINI-KUGELHÄHNE
VANNE À BILLE "MINI"
MINI VÁLVULAS A ESFERA
MINI VÁLVULAS DE ESFERA



Norma di Riferimento

Reference Standard

Entspricht Der Norm

Conforme à La Norme

Normativa de Referencia

Norma de Referência

1907/2006 REACH ✓	2011/65/CE RoHS ✓
97/23/CE (PED)	SILICON FREE

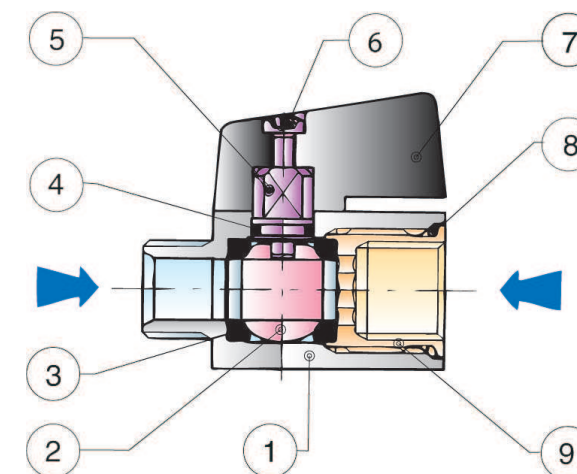

Materiali e Componenti IT

- Corpo in Ottone nichelato
- Sfera in Ottone nichelato
- Guarnizione sede sfera in PTFE
- Guarnizione O-RING in NBR
- Albero in Ottone nichelato
- Vite in acciaio
- Maniglia in PA66 Caricato vetro - 3/4 alluminio
- Guarnizione O-RING in NBR
- Ghiera o raccordo in Ottone nichelato

Component Parts and Materials GB

- Nickel-plated Brass Body
- Nickel-plated Brass Ball
- PTFE Seats
- NBR Seal O-RING
- Nickel-plated Brass Spindle
- Steel Screw
- PA66 Glass reinforced Handle -3/4 Aluminium
- NBR Seal O-RING
- Nickel-plated Brass Fitting

Komponenten und Materialien DE

- Körper Messing vernickelt
- Kugel Messing vernickelt
- Kugelsitzdichtung PTFE
- O-Ring NBR
- Spindel Messing vernickelt
- Schraube Stahl
- Handgriff PA66 Glasfaser verstärkt - 3/4 Aluminium
- O-Ring NBR
- Gewindeinsatz Messing vernickelt

Matériels et Composants FR

- Corps: laiton nickelé
- Bille: laiton nickelé
- Joint de siège: PTFE
- Joint torique: NBR
- Entraîneur: laiton nickelé
- Vis: acier
- Manette: PA66 chargé en fibre de verre - 3/4 Aluminium
- Joint torique: NBR
- Ecrou de blocage: laiton nickelé

Materiales y Componentes ES

- Cuerpo en latón niquelado
- Esfera en latón niquelado
- Junta sede esfera en PTFE
- Junta tórica O-RING en NBR
- Eje en latón niquelado
- Tornillo en acero
- Manopla en PA66 con fibra de vidrio - 3/4 aluminio
- Junta tórica O-RING en NBR
- Racor en latón niquelado

Materiais e Componentes PT

- Corpo em Latão Niquelado
- Esfera em Latão Niquelado
- Vedação da sede da esfera em PTFE
- Vedação O-RING em NBR
- Eixo em Latão Niquelado
- Parafuso em aço
- Manopla em PA66 com Fibra de Vidro - 3/4 Alumínio
- Vedação O-RING em NBR
- Conexão em Latão Niquelado



Pressioni

Pressures
Druckbereich
Pressions
Presiones
Pressões

-0.99 (-0.099 MPa)
10 bar (1 MPa)



Temperature

Temperatures
Temperatur
Températures
Temperaturas
Temperaturas

- 15 °C
+ 110 °C

Con Acqua
With Water
Mit Wasser
Avec de l'Eau
Con Agua
Com Água

0 °C
+ 90 °C



Fluidi compatibili

Aria compressa / Acqua / Oli / Vuoto

Fluids
Compressed air / Water / Oils / Vacuum

Geeignete Medien
Druckluft / Wasser / Verschiedene Oele / Vakuum

Fluides compatibles
Air comprimé / Eau / Huiles / Vide

Fluidos compatibles
Aire comprimido / Agua / Aceite / Vacío

Fluidos compatíveis
Ar comprimido / Água / Óleos / Vazio

6065

No Gas

VALVOLA A SFERA MINI FEMMINA G ISO 228 - FEMMINA G ISO 228
 MINI BALL VALVE FEMALE G ISO 228 - FEMALE G ISO 228
 MINI-KUGELHAHN INNENGEW. G ISO 228 - INNENGEW. G ISO 228
 MINI VANNE FEMELLE G ISO 228 - FEMELLE G ISO 228
 VÁLVULA A ESFERA MINI HEMBRA G ISO 228 - HEMBRA G ISO 228
 MINI-VÁLVULA DE ESFERA FÊMEA G ISO 228 - FÊMEA G ISO 228

Code	A	DN	B	C	CH	Pack.
06065 00 001	1/8	6	39	38	21	10
06065 00 002	1/4	8	40	38	21	10
06065 00 003	3/8	8	42	38	21	10
06065 00 004	1/2	10	48	42	25	10
06065 00 005	3/4	12	54	47	30	10

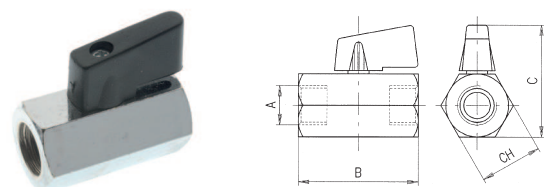

6066

No Gas

VALVOLA A SFERA MINI MASCHIO G ISO 228 - FEMMINA G ISO 228
 MINI BALL VALVE MALE G ISO 228 - FEMALE G ISO 228
 MINI-KUGELHAHN AUSSENGEW. GA ISO 228 - INNENGEW. G ISO 228
 MINI VANNE MÂLE G ISO 228 - FEMELLE G ISO 228
 VÁLVULA A ESFERA MINI MACHO G ISO 228 - HEMBRA G ISO 228
 MINI-VÁLVULA DE ESFERA ROSCA MACHO G ISO 228 - ROSCA FÊMEA G ISO 228

Code	A	DN	B	C	CH	Pack.
06066 00 001	1/8	6	39	38	21	10
06066 00 002	1/4	8	39	38	21	10
06066 00 003	3/8	8	40	38	21	10
06066 00 004	1/2	10	46	42	25	10
06066 00 005	3/4	12	51	47	30	10

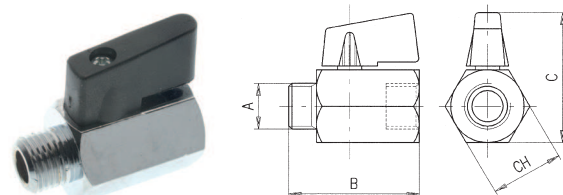

VALVOLE A SFERA

BALL VALVES
 KUGELHÄHNE
 VANNES À BILLE
 VÁLVULAS A ESFERA
 VÁLVULAS DE ESFERA



Norma di Riferimento

Reference Standard

Entspricht Der Norm

Conforme à La Norme

Normativa de Referencia

Norma de Referência

1907/2006
 REACH ✓

2011/65/CE
 RoHS ✓

97/23/CE
 (PED)

SILICON
 FREE

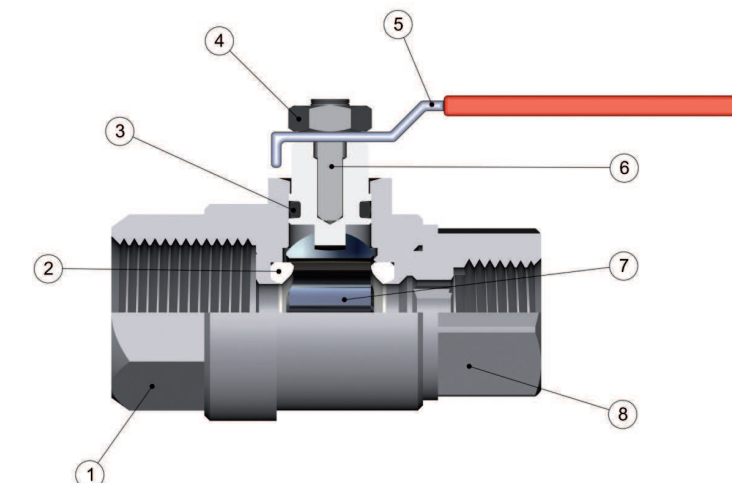

Materiali e Componenti	IT
1 Corpo in ottone nichelato	
2 Guarnizione sede sfera in PTFE	
3 Guarnizione asta: 6068 FKM 6067/6069 EPDM	
4 Dado per leva in Acciaio	
5 Leva di manovra in acciaio plastificato	
6 Asta di manovra in ottone nichelato	
7 Sfera in ottone cromato	
8 Raccordo in Ottone Nichelato	

Component Parts and Materials	GB
1 Nickel-plated Brass Body	
2 PTFE Seats	
3 Stem Seal: 6068 FKM 6067/6069 EPDM	
4 Steel Nut for lever	
5 Steel plastified Lever handle	
6 Nickel-plated Brass Stem	
7 Chrome Nickel-plated Brass Ball	
8 Nickel-plated Brass Fitting	

Komponenten und Materialien	DE
1 Körper Messing vernickelt	
2 Kugelsitzdichtung PTFE	
3 Spindeldichtung: 6068 FKM 6067/6069 EPDM	
4 Hebelmutter Stahl	
5 Bedienhebel Stahl plastifiziert	
6 Bedienspindel Messing vernickelt	
7 Kugel Messing verchromt	
8 Einschraubkörper Messing vernickelt	

Matériels et Composants	FR
1 Corps: laiton nickelé	
2 Joint de siège: PTFE	
3 Joint d'entraîneur: 6068 FKM 6067/6069 EPDM	
4 Ecrou de blocage: acier	
5 Manette: acier plastifié	
6 Entraîneur: laiton nickelé	
7 Bille: laiton chromé	
8 Raccord: laiton nickelé	

Materiales y Componentes	ES
1 Cuerpo en latón cromado	
2 Junta sede esfera PTFE	
3 Junta eje: 6068 FKM 6067/6069 EPDM	
4 Junta para leva en Acero	
5 Leva de maniobra en acero plastificado	
6 Eje de maniobra en latón niquelado	
7 Esfera en latón cromado	
8 Racor en latón niquelado	

Materiais e Componentes	PT
1 Corpo em Latão Niquelado	
2 Vedação da sede da esfera em PTFE	
3 Vedação da haste: 6068 FKM 6067/6069 EPDM	
4 Dado per leva em Aço	
5 Manopla de manobra em aço plastificado	
6 Haste de manobra em Latão Niquelado	
7 Esfera em Latão cromado	
8 Conexões em Latão Niquelado	

DIAGRAMMA PRESSIONE-TEMPERATURA
 PRESSURE-TEMPERATURE RATINGS DIAGRAM
 DRUCK-TEMPERATUR DIAGRAMM
 DIAGRAMME PRESSION / TEMPÉRATURE
 DIAGRAMA PRESIÓN-TEMPERATURA
 DIAGRAMA PRESSÃO-TEMPERATURA

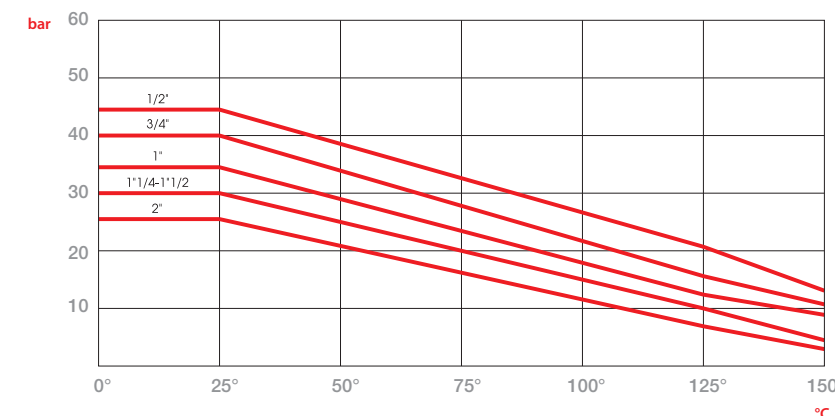

6067

VALVOLA A SFERA, FEMMINA G ISO 228 - FEMMINA G ISO 228

BALL VALVE, FEMALE G ISO 228 - FEMALE G ISO 228
 KUGELHAHN, INNENGEW. G ISO 228 - INNENGEW. G ISO 228
 VANNE À BILLE FEMELLE G ISO 228 - FEMELLE G ISO 228
 VÁLVULA A ESFERA HEMBRA G ISO 228 - HEMBRA G ISO 228
 VÁLVULA DE ESFERA, FÊMEA G ISO 228 - FÊMEA G ISO 228

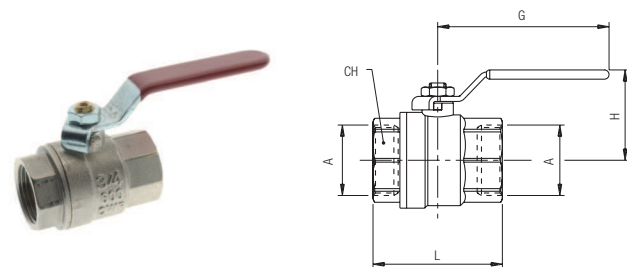

Code	A	DN	CH	L	G	H	Pack.
06067 00 001	1/2	15	25	46	88	47.5	10
06067 00 002	3/4	20	31	56.5	88	51	10
06067 00 003	1"	25	38	65.5	105	63	5
06067 00 004	1 1/4	32	48	77	105	68.5	2
06067 00 005	1 1/2	40	54	88.5	134	84.5	1
06067 00 006	2"	50	67	101.5	134	92.5	1



Fluidi compatibili
 Aria compressa / Acqua / Oli

Fluids
 Compressed air / Water / Oils

Geeignete Medien
 Druckluft / Wasser / Oele

Fluides compatibles
 Air comprimé / Eau / Huile

Fluidos compatibles
 Aire comprimido / Agua / Aceite

Fluidos compatíveis
 Ar comprimido / Água / Óleos

IT	GB
<ul style="list-style-type: none"> Fino al DN20: Valgono le condizioni riportate nel diagramma** Dal DN25 al DN50: Pressione Max: 18 bar 	<ul style="list-style-type: none"> DN 15 and 20: Use Diagram condition** From DN25 to DN50: Max Pressure: 18 bar

DE	FR
<ul style="list-style-type: none"> Bis zu DN20: Verwenden Sie die Angaben im Diagramm** Von DN25 bis DN50: Max. Druck: 18 bar 	<ul style="list-style-type: none"> DN 15 et 20: Pour définir la pression maximale, consulter le diagramme** De DN25 jusqu'à DN50: pression maximum: 18 bar

ES	PT
<ul style="list-style-type: none"> Hasta el DN20: Ver los valores representados en el diagrama** Del DN25 al DN50, Presión Máx: 18 bar 	<ul style="list-style-type: none"> DN 15 e DN20: Verifique as condições informadas no diagrama** De DN25 a DN50, Pressão Máx: 18 bar

6068

VALVOLA A SFERA PER GAS, FEMMINA RP ISO7 - FEMMINA RP ISO7

GAS BALL VALVE, FEMALE RP ISO7 - FEMALE RP ISO7
 KUGELHAHN FÜR GAS, INNENGEW. RP ISO7 - INNENGEW. RP ISO7
 VANNE À BILL POUR GAZ, FEMELLE RP ISO7 - FEMELLE RP ISO7
 VÁLVULA A ESFERA PARA GAS HEMBRA RP ISO7 - HEMBRA RP ISO7
 VÁLVULA DE ESFERA PARA GÁS, ROSCA FÊMEA RP ISO7 - ROSCA FÊMEA RP ISO7

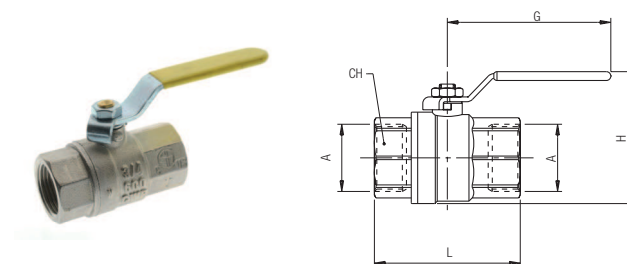

Code	A	DN	CH	L	G	H	Pack.
06068 00 007	1/4	10	22	46	88	50	10
06068 00 008	3/8	12	22	46	88	50	10
06068 00 001	1/2	15	26	59	88	58	10
06068 00 002	3/4	20	32	67.3	88	65	10
06068 00 003	1"	25	40	77.5	105	74	5
06068 00 004	1 1/4	32	49	92	105	85	2
06068 00 005	1 1/2	40	55	101.5	134	100	1
06068 00 006	2"	50	68	122.5	134	116.5	1



Omologato BS EN 331:1998
 fino a pressione Max: 5 bar.

Omologated BS EN 331:1998
 to Max pressure: 5bar.

Zugelassen nach BS EN 331:1998
 bis zu einem max. Druck von 5 bar.

Homologué BS EN 331:1998
 jusqu'à une pression de: 5bar.

Homologado BS EN 331:1998
 hasta presión Máx: 5 bar.

Homologadas BS EN 331:1998
 até a pressão Máx: 5 bar.



IT	GB
<p>Fluidi</p> <p>Dal DN15 al DN50: 1° e 2° Famiglia di gas a media pressione e 3° famiglia di gas a bassa pressione.</p>	<p>Fluids</p> <p>From DN 15 to 50: Fluids: 1st and 2nd gas family to medium pressure 3th gas family to low pressure.</p>

DE	FR
<p>Medien</p> <p>Von DN15 bis DN50: 1. und 2. Familie von Gasen für Mitteldruck und 3. Familie von Gasen für Niederdruck.</p>	<p>Fluides</p> <p>De DN15 jusqu'à DN50: 1ère et 2ème famille des gaz moyenne pression et 3ème famille des gaz base pression.</p>

ES	PT
<p>Fluidos</p> <p>Del DN15 al DN50: 1° e 2° Familia de gases a media presión y 3° familia de gas a baja presión.</p>	<p>Fluidos</p> <p>De DN15 a DN50: 1° e 2° Familia de gás a média pressão e 3° familia de gás a baixa pressão.</p>

6069

VALVOLA A SFERA MASCHIO G ISO 228 - FEMMINA G ISO 228

BALL VALVE MALE G ISO 228 - FEMALE G ISO 228
 KUGELHAHN, AUSSENGEW. G ISO 228 - INNENGEW. G ISO 228
 VANNE À BILLE, MÂLE G ISO 228 - FEMELLE G ISO 228
 VÁLVULA A ESFERA MACHO G ISO 228 - HEMBRA G ISO 228
 VÁLVULA DE ESFERA ROSCA MACHO G ISO 228 - ROSCA FÊMEA G ISO 228

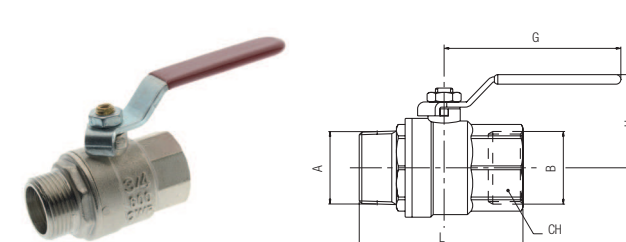

Code	A	B	DN	CH	L	G	H	Pack.
06069 00 001	1/2	1/2	15	25	56	88	47.5	10
06069 00 002	3/4	3/4	20	31	63.5	88	51	10
06069 00 003	1"	1"	25	38	74	105	63	5
06069 00 004	1 1/4	1 1/4	32	48	85	105	68.5	2
06069 00 005	1 1/2	1 1/2	40	54	100	134	84.5	1
06069 00 006	2"	2"	50	67	121.5	134	92.5	1



Fluidi compatibili
 Aria compressa / Acqua / Oli

Fluids
 Compressed air / Water / Oils

Geeignete Medien
 Druckluft / Wasser / Oele

Fluides compatibles
 Air comprimé / Eau / Huile

Fluidos compatibles
 Aire comprimido / Agua / Aceite

Fluidos compatíveis
 Ar comprimido / Água / Óleos

IT	GB
<ul style="list-style-type: none"> Fino al DN20: Valgono le condizioni riportate nel diagramma** Dal DN25 al DN50: Pressione Max: 18 bar 	<ul style="list-style-type: none"> DN 15 and 20: Use Diagram condition** From DN25 to DN50: Max Pressure: 18 bar

DE	FR
<ul style="list-style-type: none"> Bis zu DN20: Verwenden Sie die Angaben im Diagramm ** Von DN25 bis DN50: Max. Druck: 18 bar 	<ul style="list-style-type: none"> DN 15 et 20: Pour définir la pression maximale, consulter le diagramme. ** De DN25 jusqu'à DN50: pression maximum: 18 bar

ES	PT
<ul style="list-style-type: none"> Hasta el DN20: Ver los valores representados en el diagrama** Del DN25 al DN50, Presión Máx: 18 bar 	<ul style="list-style-type: none"> DN 15 e DN20: Verifique as condições informadas no diagrama** De DN25 a DN50, Pressão Máx: 18 bar

New

VALVOLA A SFERA A 3 VIE PASSAGGIO A "T" E A "L"

3 WAYS BALL VALVES FEMALE - "T" & "L"
 3-WEGE KUGELHAHN MIT "L" UND "T" BOHRUNG
 VANNE A BILLE 3 VOIES PASSAGE EN "T" ET EN "L"
 VÁLVULA DE ESFERA A 3 VÍAS PASO A "T" Y A "L"
 VÁLVULA ESFERA 3 VIAS COM PASSAGEM "T" E "L"



CARATTERISTICHE TECNICHE

TECHNICAL CHARACTERISTICS
 TECHNISCHE ANGABEN
 CARACTÉRISTIQUES TECHNIQUES
 CARACTERÍSTICAS TÉCNICAS
 CARACTERÍSTICAS TÉCNICAS



Norma di Riferimento

Reference Standard
 Entspricht Der Norm
 Conforme à La Norme
 Normativa de Referencia
 Norma de Referència

1907/2006 REACH ✓	2011/65/CE RoHS ✓
97/23/CE (PED)	SILICON FREE



Norma di Riferimento

Reference Standard
 Entspricht Der Norm
 Conforme à La Norme
 Normativa de Referencia
 Norma de Referència

1907/2006 REACH ✓	2011/65/CE RoHS ✓
97/23/CE (PED)	SILICON FREE

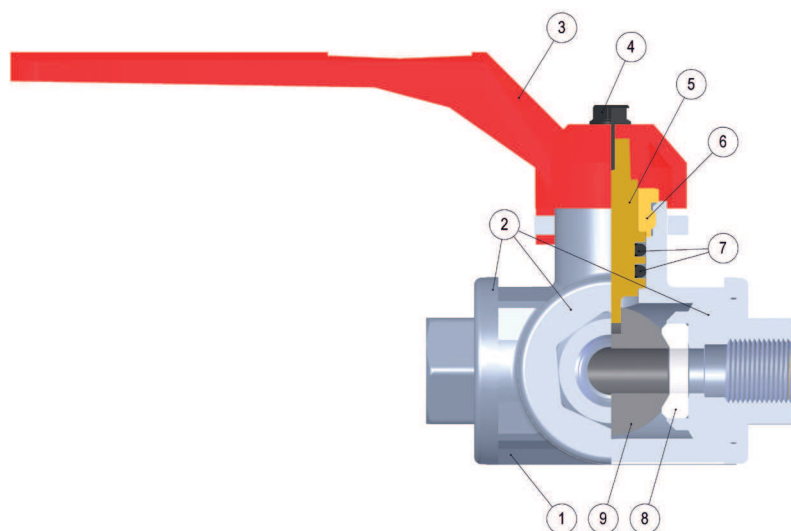

Materiali e Componenti	IT	Component Parts and Materials	GB	Komponenten und Materialien	DE
1 Corpo in ottone nichelato		1 Nickel-plated brass body		1 Körper Messing vernickelt	
2 Raccordi in ottone nichelato		2 Nickel-plated brass adaptors		2 Anschlüsse Messing vernickelt	
3 Leva in alluminio EN-AB46100		3 Aluminum handle EN-AB46100		3 Griff Aluminium EN-AB46100	
4 Vite acciaio zincato		4 Zinc plated screw		4 Schraube Stahl verzinkt	
5 Asta di manovra in ottone giallo		5 Handling needle in yellow brass		5 Spindel Messing	
6 Premiguarnizione in ottone giallo		6 Seal locker in yellow brass		6 Hülse Messing	
7 Guarnizione asta FKM		7 Needle seal FKM		7 Dichtung Spindel FKM	
8 Guarnizione sede sfera in PTFE		8 Ball seat seal PTFE		8 Kugelsitzdichtung PTFE	
9 Sfera in ottone cromato		9 Chrome-plated brass ball		9 Kugel Messing verchromt	

Matériels et Composants	FR	Materiales y Componentes	ES	Materiais e Componentes	PT
1 Corps en laiton nickelé		1 Cuerpo en latón niquelado		1 Corpo em latão niquelado	
2 Raccordement en laiton nickelé		2 Racores en latón niquelado		2 Conexões em latão niquelado	
3 Manette en aluminium EN-AB46100		3 Leva en aluminio EN-AB46100		3 Alavanca em alumínio EN-AB46100	
4 Vis en acier zingué		4 Tornillo en acero zincado		4 Parafusos em aço zincado	
5 Entraîneur en laiton		5 Eje de manobra en latón natural		5 Haste de manobra em latão amarelo	
6 Axe d'entraîneur en laiton		6 Sujeta junta en latón natural		6 Prensa-vedações em latão amarelo	
7 Joint d'entraîneur en FKM		7 Junta eje en FKM		7 Vedações da haste em FKM	
8 Joint de siège en PTFE		8 Junta sede esfera en PTFE		8 Vedações da base da esfera em PTFE	
9 Bille laiton chromé		9 Esfera en latón cromado		9 Esfera em latão cromado	



Temperature

Temperatures
 Temperatur
 Températures
 Temperaturas
 Temperaturas

- 10 °C
 + 120 °C



Fluidi compatibili

Aria compressa / Vuoto / Acqua / Oli
 Fluids
 Compressed air / Vacuum / Water / Oils
 Geeignete Medien
 Druckluft / Vakuum / Wasser / Oel
 Fluides compatibles
 Air comprimé / Vide / Eau / Huile
 Fluidos compatibles
 Aire comprimido / Vacío / Agua / Aceite
 Fluidos compatíveis
 Ar comprimido / Vácuo / Água / Óleos



Diagramma Pressione - Temperatura

Pressure - Temperature ratings diagram
 Druck - Temperatur diagramm
 Diagramme Pression - Température
 Diagrama Presión - Temperatura
 Diagrama de Pressão - Temperatura

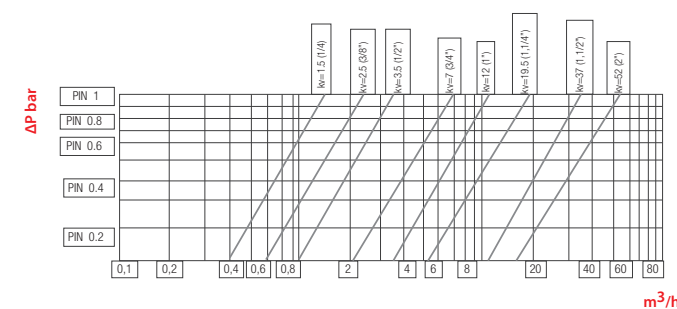
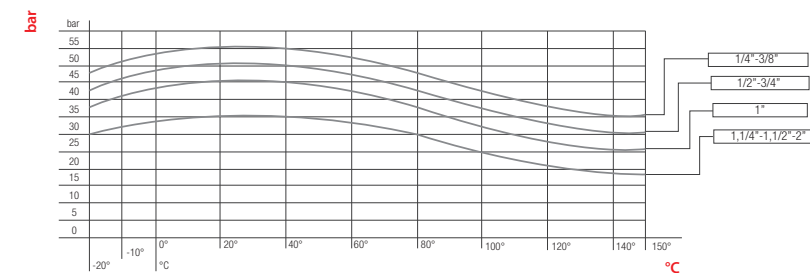

Attenzione	IT	Attention	GB	Achtung	DE
La presente valvola deve essere impiegata alle condizioni espote in questa scheda, e dalla misura 1 - 1/4" e superiori, non deve essere utilizzata per fluidi pericolosi quali: esplosivi, infiammabili, tossici e comburenti.		This valve must be used at the above described conditions. From size 1-1/4" and bigger, do not use with dangerous fluids: explosives, inflammables, inflammables, toxic and combusive.		Dieses Ventil muss unter den in diesem Anhang angegebenen Bedingungen verwendet werden. Die Abmessungen 1 1/4" und grösser, dürfen nicht für gefährliche Flüssigkeiten verwendet werden, wie zum Beispiel: hochexplosive, entzündliche, giftige und oxidierende.	

Attention	FR	Atención	ES	Atenção	PT
Cette vanne doit être utilisée dans les conditions énoncées dans la présente annexe, et à partir de 1 - 1/4 " elle ne doit pas être utilisée pour des fluides dangereux (explosifs, produits inflammables, produits toxiques...).		La presente válvula debe ser utilizada a las condiciones expuestas en esta tabla, y desde la medida 1 - 1/4" y superior, no debe ser utilizada para fluidos peligrosos tales como: explosivos, inflamables, tóxicos y oxidantes.		A presente válvula deve ser aplicada às condições expostas neste tabela, e nas medidas 1-1/4" e superiores não deve ser utilizada para fluidos perigosos, tais como: explosivos, inflamáveis, tóxicos e comburentes.	



Filettatura	IT	Threads	GB	Gewindearten	DE
Gas cilindrica conforme ISO 228 Classe A.		Parallel gas in conformity with ISO 228 Class A.		Zylindrisches Gewinde nach Norm ISO 228 Classe A.	
Filetages	FR	Roscas	ES	Roscas	PT
Filetage cylindrique conforme: ISO 228 Classe A.		Gas cilíndrica conforme ISO 228 Clase A.		Gas paralela conforme ISO 228 Classe A.	

6074

VALVOLA 3 VIE A L FEMMINA G ISO 228
 3 WAYS BALL VALVE "L" FEMALE G ISO 228
 3-WEGE WINKEL-KUGELHAHN INNENGEW. G ISO 228
 VANNE 3 VOIES EN L TARAUEE G ISO 228
 VÁLVULA 3 VIAS A L HEMBRA G ISO 228
 VÁLVULA 3 VIAS EM L ROSCA FÊMEA G ISO 228

NEW

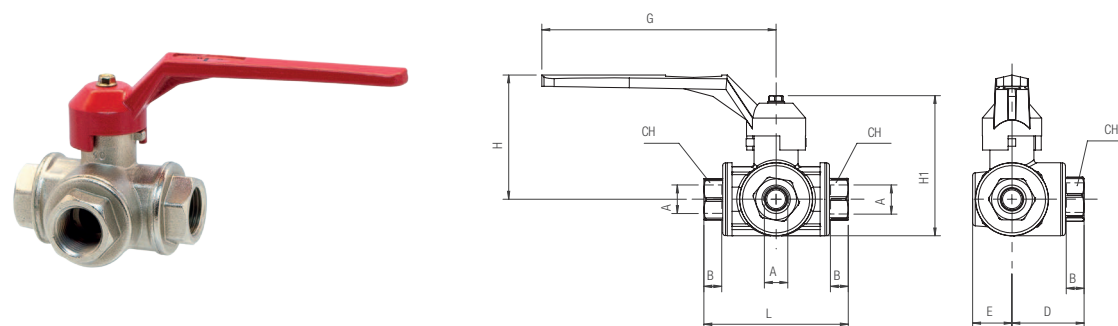

Code	Size	B	D	E	F	G	H	CH	DN	PN 20°/40 °C	Pack.
06074 V0 001	1/4	65	38,5	77	125	75	22	22	10	55	2
06074 V0 002	3/8	65	38,5	77	125	75	22	22	12	55	2
06074 V0 003	1/2	65	38,5	77	125	75	22	27	14	50	2
06074 V0 004	3/4	83	46	92	145	91	25	34	18	50	2
06074 V0 005	1	96	52	104	170	105	30	41	23	45	2
06074 V0 006	1 - 1/4	102	59	118	170	115	34	50	29	35	1
06074 V0 007	1 - 1/2	109	69	138	170	128	40	57	36	35	1
06074 V0 008	2	139	81	162	260	165	48	70	45	35	1

Funzionamento valvola a L

IT

L valve - Function

GB

Funktion Winkelkugelhahn

DE

A maniglia smontata è visibile, sull'asta di manovra, un incavo a forma di L che indica il senso di esecuzione dei fori della sfera, permettendo le seguenti combinazioni:

With disassembled handle, an L-shaped cavity on the handling needle will show the turning way of the ports. Combinations are following:

Bei abmontiertem Griff ist auf der Spindel eine L-förmige Aussparung sichtbar, welche die Laufrichtung der Kugellöcher zeigt. Folgende Kombinationen sind möglich:

Fonctionnement de la vanne en L

FR

Funcionamiento válvula a L

ES

Funcionamento da válvula com saída em L

PT

La poignée démontable et la bille percée en L permettent les combinaisons suivantes:

Con la maneta desmontada es visible, sobre el eje de maniobra un rebaje en forma de L que indica el sentido de ejecución de los agujeros de la esfera, permitiendo las siguientes combinaciones:

Com a manopla desmontada, na haste de manobra fica visível uma cavidade em forma de L, que indica o sentido de funcionamento dos orifícios da esfera, permitindo as seguintes combinações:

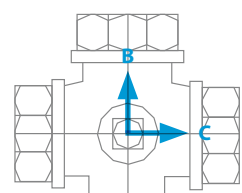

Il flusso passa da B a C (o viceversa)

Flow from B to C (or reverse)
 Der Durchfluss verläuft von B nach C (oder umgekehrt)
 Passage du fluide de B vers C (et inversement)
 El flujo pasa de B a C (o viceversa)
 O fluxo passa de B para C (ou vice-versa)

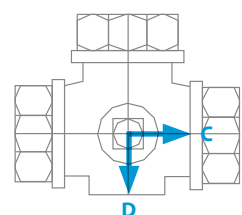

Il flusso è interrotto

Flow is stopped
 Der Durchfluss wird unterbrochen
 Passage ferme
 El flujo es interrumpido
 O fluxo é interrompido

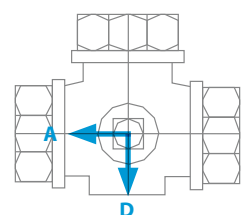

Il flusso è interrotto

Flow is stopped
 Der Durchfluss wird unterbrochen
 Passage ferme
 El flujo es interrumpido
 O fluxo é interrompido

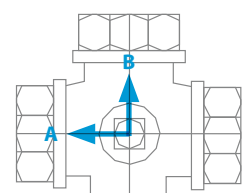

Il flusso passa da A a B (o viceversa)

Flow from A to B (or reverse)
 Der Durchfluss verläuft von A nach B (oder umgekehrt)
 Passage du fluide de A vers B (et inversement)
 El flujo pasa de A a B (o viceversa)
 O fluxo passa de A para B (ou vice-versa)

6075

VALVOLA 3 VIE A T FEMMINA G ISO 228
 3 WAYS BALL VALVE "T" FEMALE G ISO 228
 3-WEGE T-KUGELHAHN INNENGEW. G ISO 228
 VANNE 3 VOIES EN L TARAUEE G ISO 228
 VÁLVULA 3 VIAS A T HEMBRA G ISO 228
 VÁLVULA 3 VIAS EM T ROSCA FÊMEA G ISO 228

NEW

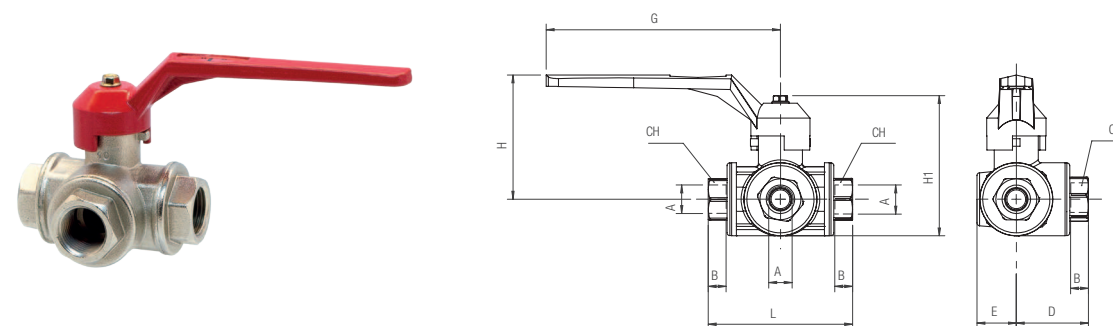

Code	Size	B	D	E	F	G	H	CH	DN	PN 20°/40 °C	Pack.
06075 V0 001	1/4	65	38,5	77	125	75	22	22	10	55	2
06075 V0 002	3/8	65	38,5	77	125	75	22	22	12	55	2
06075 V0 003	1/2	65	38,5	77	125	75	22	27	14	50	2
06075 V0 004	3/4	83	46	92	145	91	25	34	18	50	2
06075 V0 005	1	96	52	104	170	105	30	41	23	45	2
06075 V0 006	1 - 1/4	102	59	118	170	115	34	50	29	35	1
06075 V0 007	1 - 1/2	109	69	138	170	128	40	57	36	35	1
06075 V0 008	2	139	81	162	260	165	48	70	45	35	1

Funzionamento valvola a T

IT

T valve - Function

GB

Funktion T-Kugelhahn

DE

A maniglia smontata è visibile, sull'asta di manovra, un incavo a forma di T che indica il senso di esecuzione dei fori della sfera, permettendo le seguenti combinazioni:

With disassembled handle, an T-shaped cavity on the handling needle will show the turning way of the ports. Combinations are following:

Bei abmontiertem Griff ist auf der Spindel eine T-förmige Aussparung sichtbar, welche die Laufrichtung der Kugellöcher zeigt. Folgende Kombinationen sind möglich:

Fonctionnement de la vanne en T

FR

Funcionamiento válvula a T

ES

Funcionamento da válvula com saída em T

PT

La poignée démontable et la bille percée en T permettent les combinaisons suivantes:

Con la maneta desmontada es visible, sobre el eje de maniobra, una cavidade em forma de T que indica el sentido de ejecución de los agujeros de la esfera, permitiendo las siguientes combinaciones:

Com a manopla desmontada é visível, na haste de manobra, uma cavidade em forma de T que indica o sentido normal de funcionamento dos furos da esfera, permitindo a as seguintes combinações:

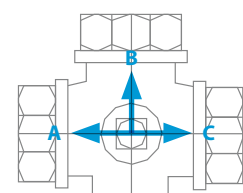

Il flusso passa in tutte le tre direzioni (A-B-C)

Flow to all directions (A-B-C)
 Der Durchfluss verläuft in alle drei Richtungen (A-B-C)
 Passage du fluide dans les trois directions (A-B-C)
 El flujo pasa en todas las tres direcciones (A-B-C)
 O fluxo passa em todas as três direções (A-B-C)

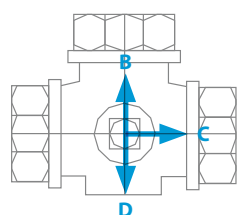

Il flusso passa solamente da B a C (o viceversa)

Flow only from B to C (or reverse)
 Der Durchfluss verläuft nur von B nach C (oder umgekehrt)
 Passage du fluide de B vers C (et inversement)
 El flujo pasa solamente de B a C (o viceversa)
 O fluxo passa somente de B para C (ou vice-versa)

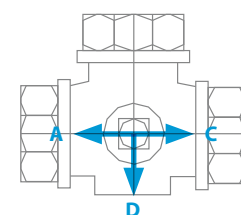

Il flusso passa solamente da A a C (o viceversa)

Flow only from A to C (or reverse)
 Der Durchfluss verläuft nur von A nach C (oder umgekehrt)
 Passage du fluide de A vers C (et inversement)
 El flujo pasa solamente de A a C (o viceversa)
 O fluxo passa somente de A para C (ou vice-versa)

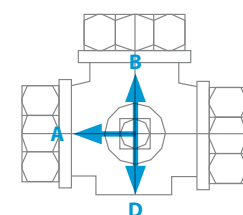

Il flusso passa solamente da A a B (o viceversa)

Flow only from A to B (or reverse)
 Der Durchfluss verläuft nur von A nach B (oder umgekehrt)
 Passage du fluide de A vers B (et inversement)
 El flujo pasa solamente de A a B (o viceversa)
 O fluxo passa somente de A para B (ou vice-versa)

FILTRO A Y

Y FILTER
Y FILTER
FILTRE Y
FILTRO A Y
FILTRO Y

Materiali e Componenti	IT
<ul style="list-style-type: none"> Corpo in ottone dal 1/4 al 2" Corpo in bronzo dal 2"1/2 al 4" Tappo in ottone Filtro in acciaio AISI 304 Guarnizione corpo in NBR 	

Component Parts and Materials	GB
<ul style="list-style-type: none"> Brass body from 1/4 to 2" Bronze body from 2"1/2 to 4" Brass Cap Steel AISI 304 Strainer NBR Body Seal 	

Komponenten und Materialien	DE
<ul style="list-style-type: none"> Körper Messing von 1/4 bis 2" Körper Bronze von 2"1/2 bis 4" Verschlussdeckel Messing Filter Edelstahl AISI 304 Körperdichtung NBR 	

Matériels et Composants	FR
<ul style="list-style-type: none"> Corps en laiton de 1/4 à 2" Corps en bronze de 2"1/2 à 4" Bouchon en laiton Filtre inox AISI 304 Joint de corps: NBR 	

Materiales y Componentes	ES
<ul style="list-style-type: none"> Cuerpo en latón de 1/4 a 2" Cuerpo en Bronce 2"1/2 a 4" Tapón en latón Filtro en acero AISI 304 Junta cuerpo en NBR 	

Materiais e Componentes	PT
<ul style="list-style-type: none"> Corpo em latão de 1/4 al 2" Corpo em bronze de 2"1/2 al 4" Tampão em latão Filtro em aço AISI 304 Vedação corpo em NBR 	



Pressioni alle temperature di riferimento

Pressures to reference temperature
Drücke gegenüber der Bezugstemperatur
Pressions en référence aux températures
Presiones a temperaturas de referencia
Pressões às temperaturas de referência

1/4 ÷ 2" 20 bar
2" - 1/2 ÷ 4" 16 bar



Temperatura di esercizio in assenza di vapore

Working temperature without steam
Betriebstemperatur ohne Dampf
Température d'utilisation sans vapeur
Temperatura de ejercicio con ausencia de vapor
Temperatura de trabalho sem presença de vapor

- 20 °C
+ 110 °C



Soglia di filtrazione

Filtration degree
Filterfeinheit
Degré de filtration
Grado de filtración
Grau de filtragem

1/4 ÷ 2" 500 µm
2"1/2 - 3" - 4" 800 µm



Fluidi compatibili

Acqua / Oli / Aria
Fluids
Water / Oils / Air
Geeignete Medien
Wasser / Oel / Air
Fluides compatibles
Eau / Huile / Air
Fluidos compatibles
Agua / Aceite / Aire
Fluidos compatíveis
Água / Óleo / Ar



Filettatura

Gas cilindrica conforme ISO 228 Classe A.
Threads
Parallel gas in conformity with ISO 228 Class A.
Gewindearten
Zylindrisches Gewinde nach Norm ISO 228 Classe A.
Filetages
Filetage cylindrique conforme: ISO 228 Class A.
Roscas
Gas cilíndrica conforme ISO 228 Clase A.
Roscas
Gas paralela conforme ISO 228 Classe A.

6035

FILTRO "Y"
"Y" FILTER
"Y" FILTER
FILTRE "Y"
FILTRO "Y"
FILTRO "Y"

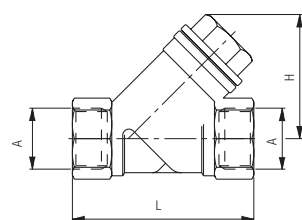

Code	A	DN	L	H	PN	KV	Pack.
06035 00 001	1/4	8	55	40	20	2,2	10
06035 00 002	3/8	10	55	40	20	3,4	10
06035 00 003	1/2	15	58	40	20	4,5	10
06035 00 004	3/4	20	70	50	20	7,9	10
06035 00 005	1"	25	87	56	20	11	5
06035 00 006	1"1/4	32	96	64	20	16	2
06035 00 007	1"1/2	40	106	73	20	22	2
06035 00 008	2"	50	126	89	20	35	1
06035 00 009	2"1/2	65	150	107	16	60	1
06035 00 010	3"	80	170	120	16	83	1
06035 00 011	4"	100	219	161	16	100	1

VALVOLE DI RITEGNO

NO RETURN VALVE
RÜCKSCHLAGVENTIL
VANNE ANTI-RETOUR
VÁLVULA DE RETENCIÓN
VÁLVULAS ANTI-RETORNO



CARATTERISTICHE TECNICHE

TECHNICAL CHARACTERISTICS
TECHNISCHE ANGABEN
CARACTÉRISTIQUES TECHNIQUES
CARACTERÍSTICAS TÉCNICAS
CARACTERÍSTICAS TÉCNICAS



Norma di Riferimento

Reference Standard
Entspricht Der Norm
Conforme à La Norme
Normativa de Referencia
Norma de Referência

1907/2006 REACH ✓
2011/65/CE RoHS ✓
97/23/CE (PED)
SILICON FREE

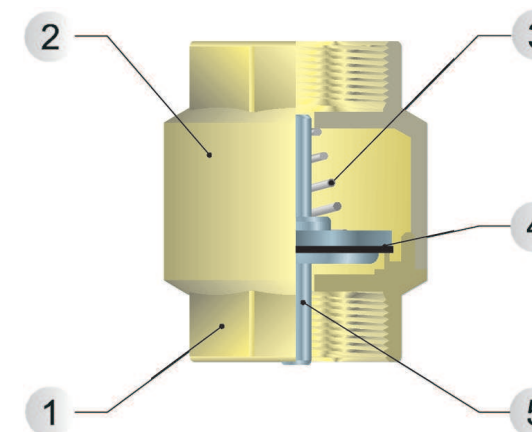

Materiali e Componenti	IT
<ul style="list-style-type: none"> Corpo in Ottone Coperchio in Ottone Molla in acciaio inox Guarnizione in NBR Otturatore in plastica 	

Component Parts and Materials	GB
<ul style="list-style-type: none"> Brass Body Brass Cover Cap Stainless steel Spring NBR Seal Plastic Shutter 	

Komponenten und Materialien	DE
<ul style="list-style-type: none"> Körper Messing Einschraubkörper Messing Feder Edelstahl Dichtung NBR Verschluss Kunststoff 	

Matériels et Composants	FR
<ul style="list-style-type: none"> Corps: laiton Corps: laiton Ressort: inox Joint: NBR Obtuteur: plastique 	

Materiales y Componentes	ES
<ul style="list-style-type: none"> Cuerpo en latón Cuerpo en latón Muelle en Acero Inox Junta en NBR Obturator en material plástico 	

Materiais e Componentes	PT
<ul style="list-style-type: none"> Corpo em Latão Cobertura em Latão Mola em aço inox Vedação em NBR Obturator em plástico 	



Pressioni

Pressures
Druckbereich
Pressions
Presiones
Pressões

3/8 ÷ 1" PN 1"-1/4 ÷ 2"
12 bar 10 bar



Temperature

Temperatures
Temperatur
Températures
Temperaturas
Temperaturas

0 °C
+ 90 °C



Fluidi compatibili

Aria compressa / Acqua / Oli
Fluids
Compressed air / Water / Oils
Geeignete Medien
Druckluft / Wasser / Oel
Fluides compatibles
Aire comprimé / Eau / Huile
Fluidos compatibles
Aire comprimido / Agua / Aceite
Fluidos compatíveis
Ar comprimido / Água / Óleo

