

## Circular Sight Glass Fitting Stainless Steel for use in non-pressurized vessels

### Viewing diameter based on DIN 28120

Sight glass fittings are circular flanged ports for welding into or onto a vessel wall. The block and the cover flange are screwed together tightly, with the sight glass disk and an independent gasket to the upper and the lower flange respectively positioned between them.

The advantages of these lightweight low profile windows for pressureless vessels (over the standard 28120 format) are:

- smaller outer diameter and therefore vessel cutout
- shallower height above weld
- lower weight
- easier to clean
- lower cost

- **Viewing diameter:** 80 to 225 mm

- **Application:**

For observation of interior of tanks, silos, stirred vessels, separators, pipelines etc.

- **Operating conditions:**

Pressure: non-pressurized

Temperature: max. 150°C with sodalime glass DIN 8902  
max. 280°C with borosilicate glass DIN 7080  
higher temperatures on request

- **Possible combinations:**

Can be combined with Lumiglas luminaires when used in explosion hazardous as well as non explosion hazardous areas. The cover flange is then drilled and tapped to suit luminaire mounting bracket.

A screen wiper SW 1 and a spray device can also be mounted.

- **Certificates/testing:**

Depending on customer requirements and at extra cost, can be provided to DIN EN 10204 3.1/3.2

- **Component materials** shown in adjoining exploded view are:

item	part	material
1	base flange	stainless steel 1.4571 (316 Ti) or other
2	gasket	KLINGERSil C-4400, Silikon, PTFE or other
3	sight glass disc	- sodalime glass: toughened DIN 8902 - borosilicate glass: toughened DIN 7080
4	cover flange	stainless steel 1.4571 (316 Ti) or other
5	securing bolts	stainless steel A2 or other

- **Installation:**

After welding in the base flange (1) into the vessel wall, gaskets (2), glass sight glass disc (3) and cover flange (4) are carefully laid and bolted together with bolts (5). Tighten progressively on a diametric cross basis with socket spanner.

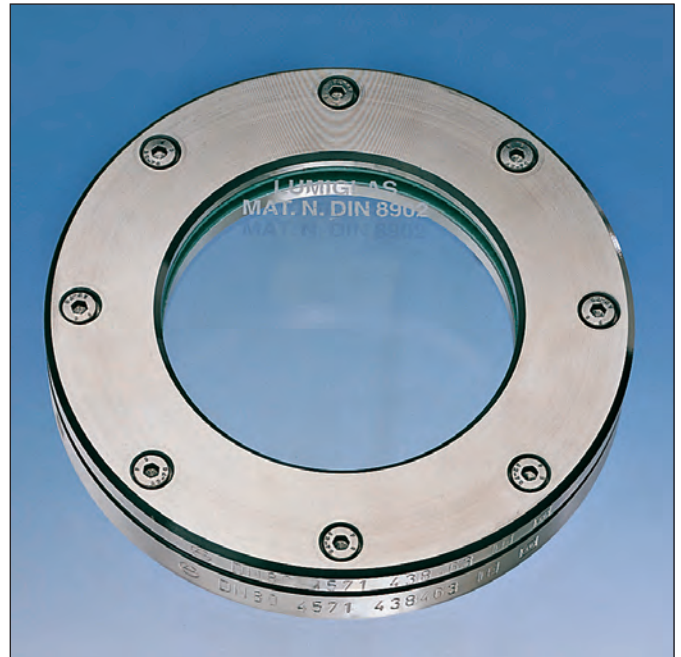

Circular sight glass fitting in stainless steel

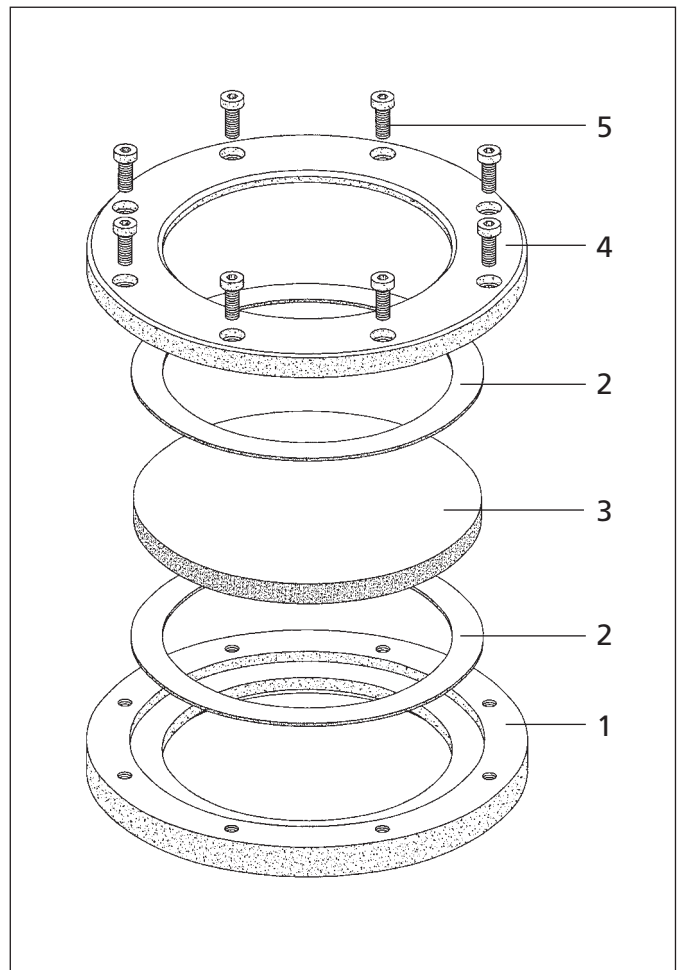

Exploded view of circular sight glass fitting in stainless steel



• Dimensions for circular sight glass fitting stainless steel, viewing diameter based on DIN 28120

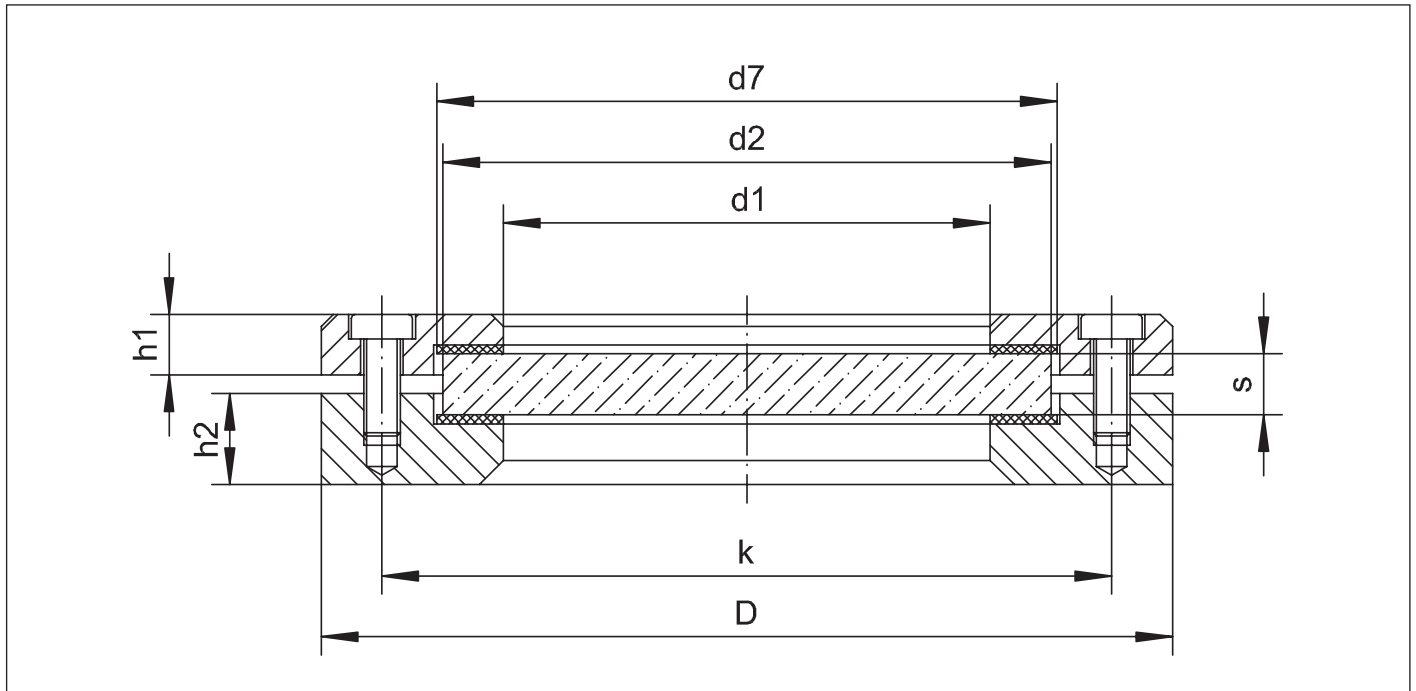

Size		1	2	3	4	5	6	7
Nominal bore	DN	50	80	100	125	150	200	300
Viewing diameter	d1	80	100	125	150	175	225	300
Sight glass disc	d2	100	125	150	175	200	250	325
	s	10	10	10	10	10	10	15
Flanges	D	140	165	190	215	240	290	370
	k	120	145	170	195	220	270	345
	h1	10	10	10	10	10	10	15
	h2	15	15	15	15	15	15	20
Fastening bolts	no.	4	8	8	8	8	8	12
	Size	M 6	M 6	M 6	M 6	M 6	M 6	M 8
Gaskets (side with product contact and atmospheric side)	d1	80	100	125	150	175	225	327
	d7	102	127	152	177	202	252	300

• Ordering data:

- Fitting (DIN) and construction
- Nominal bore (DN) / nominal pressure (PN)
- Material: base flange, test certification 3.1/3.2 on request  
cover flange, test certification 3.1/3.2 on request  
bolts  
glass disc  
gaskets

