

Ball Valves PN 16/40 AIT & IIT Construction (Carbon Steel and Stainless Steel)

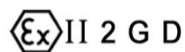

Fig. 256/254

Manufacturing program:



Quality & Environmental Management:

Ball Valves PN 16/40

DN 65 - 200 PN 16

DN 15 - 150 PN 40

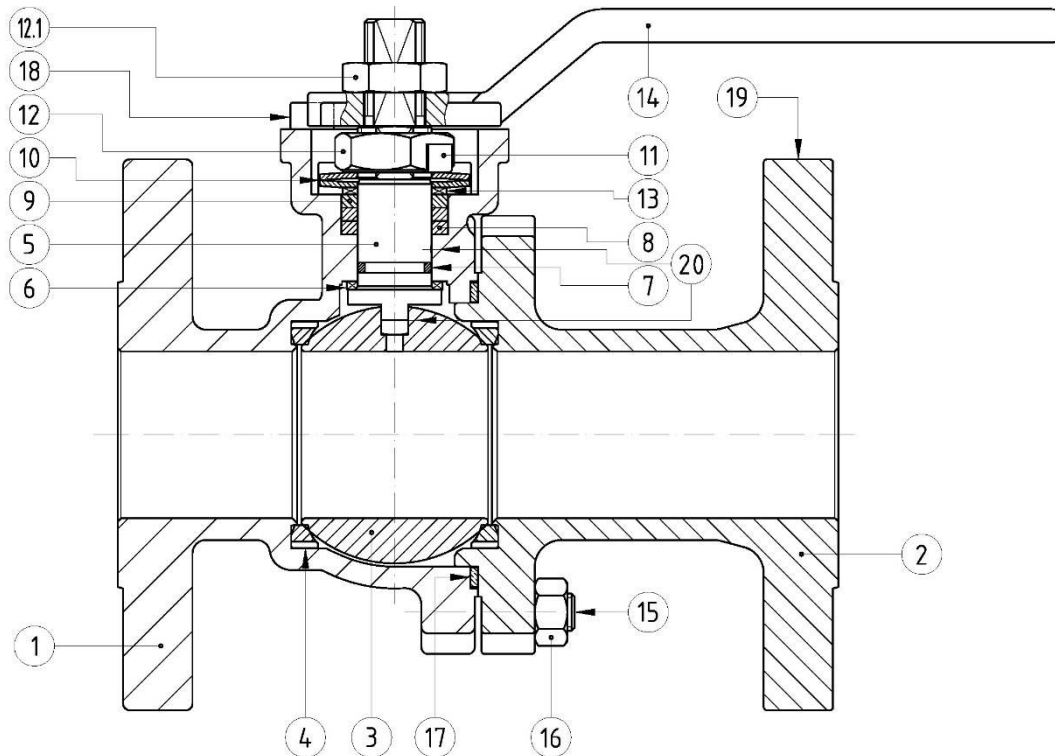
Parts and materials

Item	Description	Material	
		AIT	IIT
1	Body	1.0619	1.4408
2	Body connector	1.0619	1.4408
3	Ball	A 351 Gr. CF8M (DN-15 ~ 25 A 479 Tp.316)	
4	Seat ring	PTFE	
5	Stem	A 479 Tp.316	
6	Stem thrust seal	25% G.F. PTFE	
7	"O" Ring	FKM	
8	Gland packing	Graphite	
9	Gland	AISI 303	
10	Disk spring	Inconel - 718	
11	Locking washer	AISI 304	
12	Gland nut	AISI 303	
12.1	Nut	AISI 303	
13	Antifriction washer	25% G.F. PTFE	
14	Wrench	A 216 Gr. WCB	
15	Stud	A 193 Gr. B7M	A 193 Gr. B8M
16	Nut	A 194 Gr. 2HM	A 194 Gr. 8M
17	Spiralwound gasket	AISI 316L + PTFE + Graphite	
18	Bolt	A2	
19	Identification plate	Stainless St.	
20	Antistatic Device	Stainless St.	



Ball Valves PN 16/40

DN 65 - 200 PN 16

DN 15 - 150 PN 40

Dimensions

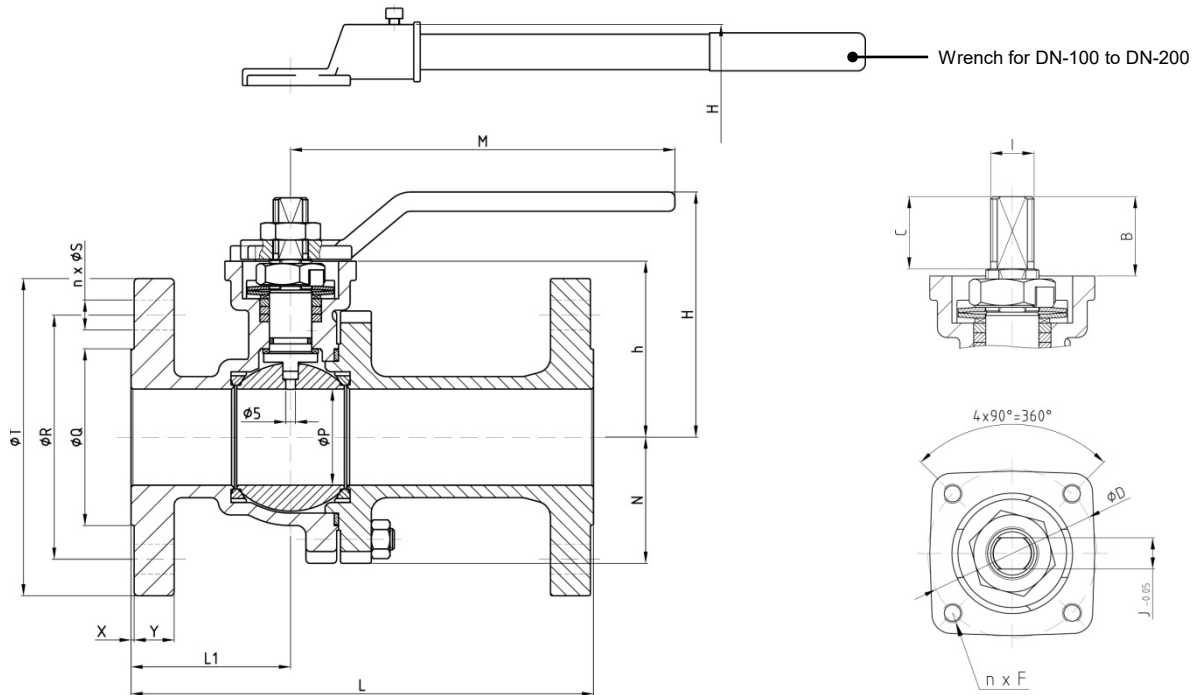

Series 256 (PN 16)

DN	ØP	L	L1	ØQ	ØR	n x ØS	ØT	X	Y	h	N	H	M	Weight
65	65	170	72	122	145	4 x 18	185	2	16	104	78	140	350	13,3
80	78	180	73	138	160	8 x 18	200	2	18	118,5	87	190	450	19,1
100	100	190	83	158	180	8 x 18	220	2	18	144	108	192,5	466	25,6
125	125	325	120	188	210	8 x 18	250	2	20	184	134	240	775	47,6
150	151	350	135	212	240	8 x 22	285	2	20	203	152	259	775	63,5
200	203	400	200	268	295	12 x 22	340	2	21	250	202	319	845	115,3

(*) Dimensions in mm

Series 254 (PN 40)

DN	ØP	L	L1	ØQ	ØR	n x ØS	ØT	X	Y	h	N	H	M	Weight
15	15	115	53	45	65	4 x 14	95	2	14	41	31	68	170	2,4
20	20	120	52	58	75	4 x 14	105	2	16	43	33	70	170	3,2
25	25	125	52	68	85	4 x 14	115	2	16	58,5	39	86	170	4,1
32	32	130	54	78	100	4 x 18	140	2	16	63,5	43	89,5	170	5,8
40	40	140	55	88	110	4 x 18	150	2	16	86,5	48	122,5	215	8,1
50	50	150	61	102	125	4 x 18	165	2	18	91,5	63	127,5	215	10,6
65	65	170	72	122	145	8 x 18	185	2	20	104	78	140	350	14,8
80	78	180	73	138	160	8 x 18	200	2	22	118,5	87	190	450	20,6
100	100	190	83	158	190	8 x 22	235	2	22	144	108	192,5	466	29,2
125	125	325	120	188	220	8 x 26	270	2	24	184	134	240	775	53,6
150	151	350	135	212	250	8 x 26	300	2	26	203	152	259	775	74,7

(*) Dimensions in mm

Actuator connection

DN	ISO 5211	B	C	ØD	n x F	I	J
15	F 05	18	11	50	4 x M6	M10	7
20	F 05	18	11	50	4 x M6	M10	7
25	F 05	22	21	50	4 x M6	M12	8
32	F 05	22	21	50	4 x M6	M12	8
40	F 07	33	32	70	4 x M8	M18	12
50	F 07	33	32	70	4 x M8	M18	12
65	F 07	34	33	70	4 x M8	M22	15
80	F 10	34	33	102	4 x M10	M22	15
100	F 10	45	43,5	102	4 x M10	M28	19
125	F 12	56	54,5	125	4 x M12	M36	24
150	F 12	56	54,5	125	4 x M12	M36	24
200	F 14	69	67	140	4 x M16	M48	32

(*) Dimensions in mm



93 699 46 04



pedidos@suministrosrado.com www.suministrosrado.com



Ball Valves PN 16/40

DN 65 - 200 PN 16
DN 15 - 150 PN 40

General Characteristics, Torque & KV

GENERAL CHARACTERISTICS	Fig.256/254 Series SFF	Split Body	Floating Ball	Full Bore
DESIGN STANDARDS				
Valves design	EN 1983	ISO 17292		
Body design	EN 12516			
Shell thickness	ISO 17292			
Flanges	EN 1092-1			
Face to face dimensions	EN 558-1 Series 27			
Actuator mounting flange	ISO 5211	DIN 3337	EN 15081	
Shell finishing quality	MSS SP 55			
Marking	EN 19	CE - PED		
TESTS AND CERTIFICATES				
Quality Assurance	ISO 9001	CE-PED		
Fire Safe certification	ISO 10497: 2004			
Pressure testing	ISO 17292	EN 12266		
Other	ISO 14001	ATEX		

Torque Values in Nm

VALVE SIZE	AT DIFFERENTIAL PRESSURE						VALVE SIZE	AT DIFFERENTIAL PRESSURE					
	16 bar			40 bar				16 bar			40 bar		
	PTFE	PTFE + CG	PTFE + GF	PTFE	PTFE + CG	PTFE + GF		PTFE	PTFE + CG	PTFE + GF	PTFE	PTFE + CG	PTFE + GF
DN 15	--	--	--	8	10	9	DN 65	51	103	68	74	100	110
DN 20	--	--	--	12	18	16	DN 80	77	171	156	118	170	190
DN 25	--	--	--	14	24	22	DN 100	116	190	176	136	290	330
DN 32	--	--	--	22	31	28	DN 125	159	710	660	204	500	610
DN 40	--	--	--	27	48	45	DN 150	215	850	830	408	750	920
DN 50	--	--	--	50	73	72	DN 200	493	1200	1200	--	--	--

Torque Variation as function of frequency

FREQUENCY	TORQUE MULTIPLIER
Once per day	1
Once per month	1.3
Once per 6 month	1,5

(*) Functional torque may vary depending on the type of fluid

Kv Values in m³/h

DN 15	DN 20	DN 25	DN 32	DN 40	DN 50
20	40	75	130	170	270
DN 65	DN 80	DN 100	DN 125	DN 150	DN 200
550	1000	1650	3000	4200	9000



93 699 46 04



pedidos@suministrosrado.com www.suministrosrado.com



Ball Valves PN 16/40

DN 65 - 200 PN 16

DN 15 - 150 PN 40

Pressure & Temperature Chart

Pressure-Temperature chart

1.0619

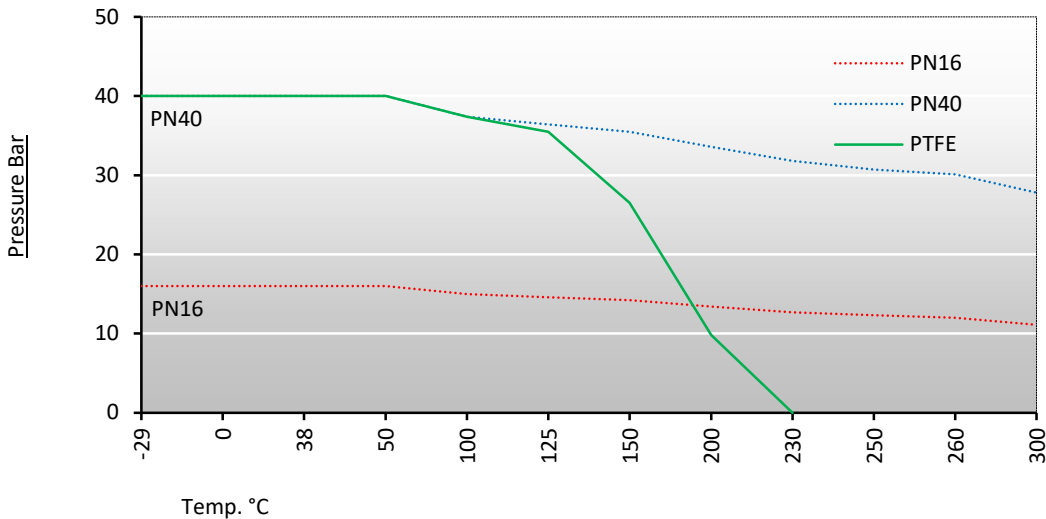

1.4408

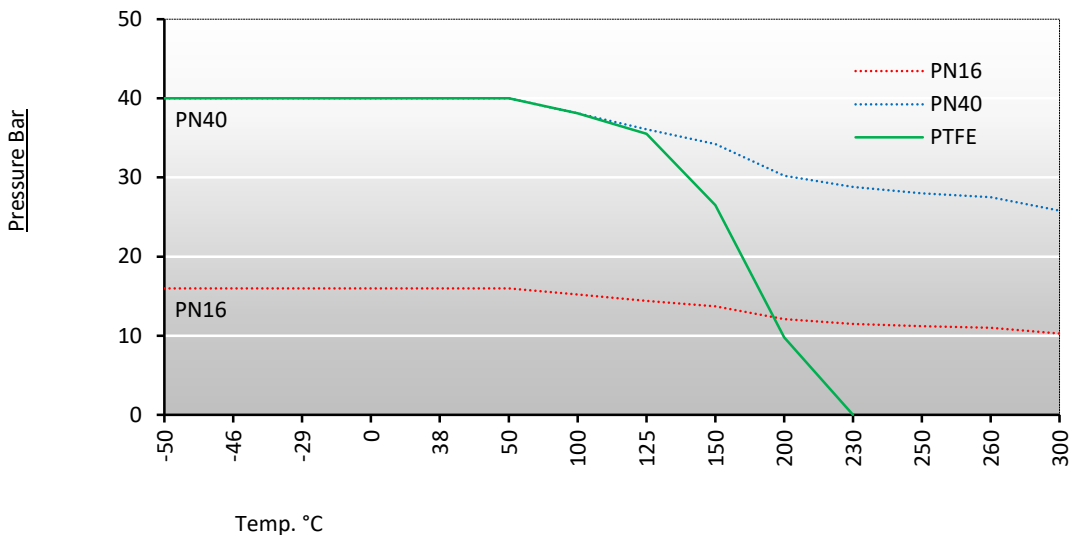

93 699 46 04



pedidos@suministrosrado.com www.suministrosrado.com